



H TECHNICAL PROCEDURE

PRIMAAX® EX • PRIMAAX® Rear Air Suspension for Volvo Vehicles

SUBJECT: Service Instructions
LIT NO: 17730-254
DATE: December 2023

REVISION: E

TABLE OF CONTENTS

Section 1	Introduction	2	Section 8	Component Replacement	
Section 2	Product Description	2	Fasteners	28	
Section 3	Important Safety Notice	4	Height Control Valve	28	
Section 4	Special Tools	8	Air Spring	28	
Section 5	Parts Lists	10	Shock Absorber	30	
Section 6	Preventive Maintenance		Longitudinal Torque Rod	31	
	Hendrickson Recommended		Transverse Torque Rod	32	
	Inspection Intervals	15	Discontinued – Support Beam Assembly		
	Component Inspection	16	and Cross Tube	32	
	U-bolt Fasteners	17	U-beam Assembly	32	
	Air Fittings	17	D-pin Bushing	36	
	QUIK-ALIGN Pivot Bushing and		QUIK-ALIGN Pivot Bushing	38	
	D-pin Bushing	18	Top Pad	43	
	Longitudinal and Transverse Torque Rods	20	Bottom Cap and Axle Spacer (if equipped)	46	
	Shock Absorber	21	Frame Hanger	48	
Section 7	Alignment & Adjustments		Axle Stops	50	
	Ride Height	23	Section 9	Torque Specifications	52
	Drive Axle Alignment Inspection	23	Section 10	Troubleshooting Guide	56
	Axle Pinion Angle	24			
	Axle Lateral Alignment	24			
	Axle Alignment	25			
	Pinion Angle Adjustment	27			



SECTION 1

Introduction

This publication is intended to acquaint and assist maintenance personnel in the preventive maintenance, service, repair and rebuild of PRIMAAX® EX • PRIMAAX® rear air suspension system as installed on applicable Volvo vehicles.

NOTE

Use only Hendrickson Genuine parts for servicing this suspension system.

It is important to read and understand this entire Technical Procedure publication prior to performing any maintenance, service, repair, or rebuild of this product. The information in this publication contains parts lists, safety information, product specifications, features, proper maintenance, service, repair and rebuild instructions for the PRIMAAX EX • PRIMAAX suspensions.

Hendrickson reserves the right to make changes and improvements to its products and publications at any time. Contact Hendrickson Tech Services for information on the latest version of this manual at 1-866-755-5968 (toll-free U.S. and Canada), 630-910-2800 (outside U.S. and Canada) or email: techservices@hendrickson-intl.com.

The latest revision of this publication is also available online at hendrickson-intl.com.

SECTION 2

Product Description

PRIMAAX EX — MAAXimize the performance of vocational and heavy-haul vehicles with a suspension engineered specifically for demanding on- and off- highway conditions. With over a 100 years of robust suspension design, Hendrickson delivers another premium suspension with PRIMAAX EX. Rugged, dependable and extensively tested in challenging applications, PRIMAAX EX suspensions pave a new road for suspension technology. Drivers, cargo and vehicles are major investments that require protection. PRIMAAX EX suspensions adjust to variations in load and road conditions for optimal ride and performance. This low-maintenance design delivers greater stability for improved control on and off the job site.

- **Air springs** — Large volume, low frequency design for improved ride. Advanced design air springs lift and support the load with less air pressure.
- **Cast structural beams** — Integrated end caps for increased reliability. Utilizes premium materials to improve durability. Robust rubber bushings help improve service life and eliminate lubrication requirements. Designed for increased disc brake clearance and compatibility.
- **D-pin axle connection and clamp group** — Decreases torsional axle stress for reduced maintenance and increased joint integrity. Integrated axle stop contact pads reduce axle stress. Newly designed torque rod bar-pin connection for increased reliability and reduced maintenance time.
- **Heavy-duty shock absorbers** — Positioned and tuned for optimum damping characteristics and protect air springs from over-extension.
- **QUIK-ALIGN® Axle Alignment System** — Allows for easy axle alignment without shims. Reduces maintenance time and helps extend tire life.
- **Torque Rods** — Optimized configuration helps improve handling and roll stiffness for expanded applications. Premium retained rubber bushings for increased service life and resistance to walk-out. Designed for optimum clearance and articulation. Alternative torque rods available for disc brake use.



FIGURE 2-1

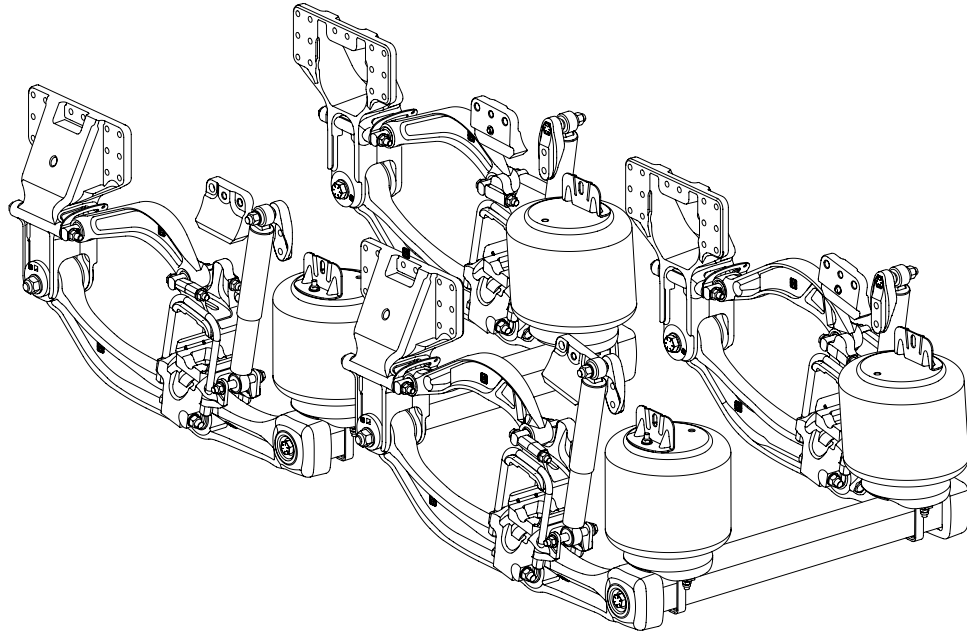

PRIMAAX® EX Specifications for Volvo Vehicles

	Single Axle 23K	Tandem Axle 46K	Tridem Axle 69K
Capacity	23,000 lbs. (10,433 kg)	46,000 lbs. (20,865 kg)	69,000 lbs. (31,298 kg)
Job Site Travel Rating¹	30,000 lbs. (13,608 kg)	60,000 lbs. (27,216 kg)	90,000 lbs. (40,823 kg)
Axle Spacing	—	54" - 72.5" (1,372-1,842 mm)	108" (2,743 mm)
Axle Travel²	7.0" (178 mm) • 7.5" (190 mm)		
Ground Clearance	9.25" (235 mm)		
Lift Axles	Approved		
Ride Heights³	8½" (216 mm) • 10" (254 mm)		
Engine Torque Restrictions	None		

1. Operators using vehicles equipped with liftable pusher or tag axles must not exceed published ratings. Ratings are limited to no more than five percent of vehicle operation at a speed not to exceed five mph. Liftable pusher or tag axles should be raised (or unloaded) to improve vehicle maneuverability in off-road use or when vehicle is empty. Site travel ratings are consistent with specifications and must not be exceeded.
2. Axle travel may be limited by vehicle manufacturer; axle stop settings may restrict suspension’s articulation.
3. For different ride height options, please contact Hendrickson, your vehicle manufacturer or authorized vehicle dealer for further information.
4. Some vehicle configurations, such as vehicles equipped with outriggers, may require alternate suspension air valves. Contact vehicle manufacturer or Hendrickson for more information.

U.S. and foreign patents granted and/or pending.



SECTION 3

Important Safety Notice

Proper maintenance, service, and repair are important to the reliable operation of the suspension. The procedures recommended by Hendrickson and described in this technical publication are methods of performing such maintenance, service, and repair.

This technical publication should be read carefully to help prevent personal injury and to assure that proper methods are used. Improper maintenance, service, or repair may damage the vehicle, cause personal injury, render the vehicle unsafe in operation, or void the manufacturer's warranty.

Failure to follow the safety precautions in this manual can result in personal injury and/or property damage. Carefully read and understand all safety related information within this publication, on all decals and in all such materials provided by the vehicle manufacturer before conducting any maintenance, service, or repair.

■ EXPLANATION OF SIGNAL WORDS

Hazard "Signal Words" (Danger • Warning • Caution) appear in various locations throughout this publication. Information accented by one of these signal words must be observed to help minimize the risk of personal injury to service personnel, or possibility of improper service methods which may damage the vehicle or render it unsafe.



This is the safety alert symbol. It is used to alert you to potential personal injury hazards. Obey all safety messages that follow this symbol to avoid possible injury or death.

Additional Notes or Service Hints are utilized to emphasize areas of procedural importance and provide suggestions for ease of repair. The following definitions indicate the use of these signal words as they appear throughout the publication.



INDICATES AN IMMINENTLY HAZARDOUS SITUATION, WHICH IF NOT AVOIDED, WILL RESULT IN SERIOUS INJURY OR DEATH.



INDICATES A POTENTIAL HAZARDOUS SITUATION WHICH, IF NOT AVOIDED, CAN RESULT IN SERIOUS INJURY OR DEATH.



INDICATES A POTENTIAL HAZARDOUS SITUATION WHICH, IF NOT AVOIDED, MAY RESULT IN MINOR OR MODERATE INJURY.

NOTE

An operating procedure, practice condition, etc., which is essential to emphasize.

SERVICE HINT

A helpful suggestion that will make the servicing being performed a little easier and/or faster.

Also note that particular service operations may require the use of special tools designed for specific purposes. These special tools can be found in the "Special Tools" section of this publication.



The torque symbol alerts you to tighten fasteners to a specified torque value. Refer to Torque Specifications section of this publication.



■ SAFETY PRECAUTIONS

WARNING

FASTENERS

DISCARD USED FASTENERS. ALWAYS USE NEW FASTENERS TO COMPLETE A REPAIR. FAILURE TO DO SO COULD RESULT IN FAILURE OF THE PART, OR MATING COMPONENTS, ADVERSE VEHICLE HANDLING, PERSONAL INJURY, OR PROPERTY DAMAGE.

LOOSE OR OVER TORQUED FASTENERS CAN CAUSE COMPONENT DAMAGE, ADVERSE VEHICLE HANDLING, PROPERTY DAMAGE, OR SEVERE PERSONAL INJURY. MAINTAIN CORRECT TORQUE VALUE AT ALL TIMES. CHECK TORQUE VALUES ON A REGULAR BASIS AS SPECIFIED, USING A REGULARLY CALIBRATED TORQUE WRENCH. TORQUE VALUES SPECIFIED IN THIS TECHNICAL PUBLICATION ARE FOR HENDRICKSON SUPPLIED FASTENERS ONLY. IF NON-HENDRICKSON FASTENERS ARE USED, FOLLOW TORQUE SPECIFICATIONS LISTED IN THE VEHICLE MANUFACTURER'S SERVICE MANUAL.

WARNING

QUIK-ALIGN FASTENERS

DISCARD USED QUIK-ALIGN FASTENERS. ALWAYS USE NEW QUIK-ALIGN FASTENERS TO COMPLETE A REPAIR. FAILURE TO DO SO COULD RESULT IN FAILURE OF THE PART, OR MATING COMPONENTS, ADVERSE VEHICLE HANDLING, PERSONAL INJURY, OR PROPERTY DAMAGE.

DO NOT ASSEMBLE THE QUIK-ALIGN JOINT WITHOUT THE PROPER FASTENERS. USE ONLY HENDRICKSON COATED GENUINE FASTENERS TO SUSTAIN PROPER CLAMP FORCE. ENSURE THAT THE QUIK-ALIGN FASTENER'S TORQUE VALUES ARE SUSTAINED AS RECOMMENDED IN THE TORQUE SPECIFICATIONS SECTION IN THIS PUBLICATION. FAILURE TO FOLLOW THE ABOVE ITEMS CAN CAUSE ADVERSE VEHICLE HANDLING RESULTING IN PERSONAL INJURY OR PROPERTY DAMAGE AND WILL VOID ANY APPLICABLE WARRANTIES. FOLLOW VEHICLE MANUFACTURER'S FASTENER ORIENTATION WHEN PERFORMING ANY MAINTENANCE, SERVICE, OR REPAIR.

WARNING

LOAD CAPACITY

ADHERE TO THE PUBLISHED CAPACITY RATINGS FOR THE SUSPENSION. ADD-ON AXLE ATTACHMENTS AND OTHER LOAD TRANSFERRING DEVICES, SUCH AS LIFTABLE AXLES, CAN INCREASE THE SUSPENSION LOAD ABOVE ITS RATED AND APPROVED CAPACITIES, WHICH CAN RESULT IN COMPONENT DAMAGE AND ADVERSE VEHICLE HANDLING, POSSIBLY CAUSING PERSONAL INJURY OR PROPERTY DAMAGE.

WARNING

MODIFYING COMPONENTS

DO NOT MODIFY OR REWORK PARTS WITHOUT AUTHORIZATION FROM HENDRICKSON. DO NOT SUBSTITUTE REPLACEMENT COMPONENTS NOT AUTHORIZED BY HENDRICKSON. USE OF MODIFIED, REWORKED, SUBSTITUTE OR REPLACEMENT PARTS NOT AUTHORIZED BY HENDRICKSON MAY NOT MEET HENDRICKSON'S SPECIFICATIONS, AND CAN RESULT IN FAILURE OF THE PART, ADVERSE VEHICLE HANDLING, POSSIBLE PERSONAL INJURY OR PROPERTY DAMAGE, AND WILL VOID ANY APPLICABLE WARRANTIES. USE ONLY HENDRICKSON AUTHORIZED REPLACEMENT PARTS.

CAUTION

PROCEDURES AND TOOLS

A TECHNICIAN USING A SERVICE PROCEDURE OR TOOL WHICH HAS NOT BEEN RECOMMENDED BY HENDRICKSON MUST FIRST SATISFY THEMSELVES THAT NEITHER THEIR SAFETY NOR THE VEHICLE'S SAFETY WILL BE JEOPARDIZED BY THE METHOD OR TOOL SELECTED. INDIVIDUALS DEVIATING IN ANY MANNER FROM THE INSTRUCTIONS PROVIDED WILL ASSUME ALL RISKS OF CONSEQUENTIAL PERSONAL INJURY OR DAMAGE TO EQUIPMENT INVOLVED.

WARNING

SUPPORT THE VEHICLE PRIOR TO SERVICING

PLACE THE VEHICLE ON A LEVEL FLOOR AND CHOCK THE WHEELS TO PREVENT THE VEHICLE FROM MOVING OR ROLLING. DO NOT WORK AROUND OR UNDER A RAISED VEHICLE SUPPORTED BY ONLY A FLOOR JACK OR OTHER LIFTING DEVICE. ALWAYS SUPPORT A RAISED VEHICLE WITH RIGID SAFETY STANDS. FAILURE TO DO SO CAN CAUSE SERIOUS PERSONAL INJURY OR DAMAGE TO EQUIPMENT.

WARNING

TORQUE RODS

THIS HENDRICKSON SUSPENSION REQUIRES TORQUE RODS FOR SUSPENSION PERFORMANCE AND VEHICLE STABILITY. IF THESE TORQUE RODS ARE DISCONNECTED OR ARE NON-FUNCTIONAL, DO NOT OPERATE THE VEHICLE. OPERATING A VEHICLE WITH DISCONNECTED OR NON-FUNCTIONAL TORQUE RODS CAN RESULT IN ADVERSE VEHICLE HANDLING, COMPONENT DAMAGE, SUSPENSION/VEHICLE DAMAGE, AND/OR SEVERE PERSONAL INJURY.

WARNING**PERSONAL PROTECTIVE EQUIPMENT**

ALWAYS WEAR PROPER EYE PROTECTION AND OTHER REQUIRED PERSONAL PROTECTIVE EQUIPMENT TO HELP PREVENT PERSONAL INJURY WHEN PERFORMING VEHICLE MAINTENANCE, REPAIR OR SERVICE.

WARNING**TORCH/WELDING**

DO NOT USE A CUTTING TORCH TO REMOVE ANY FASTENERS. THE USE OF HEAT ON SUSPENSION COMPONENTS WILL ADVERSELY AFFECT THE STRENGTH OF THESE PARTS. A COMPONENT DAMAGED IN THIS MANNER CAN RESULT IN THE ADVERSE VEHICLE HANDLING AND POSSIBLE PERSONAL INJURY OR PROPERTY DAMAGE.

EXERCISE EXTREME CARE WHEN HANDLING OR PERFORMING MAINTENANCE IN THE AREA OF THE SUPPORT BEAM. DO NOT CONNECT ARC WELDING GROUND LINE TO THE SUPPORT BEAM. DO NOT STRIKE AN ARC WITH THE ELECTRODE ON THE SUPPORT BEAM. DO NOT USE HEAT NEAR THE SUPPORT BEAM ASSEMBLY. DO NOT NICK OR GOUGE THE SUPPORT BEAM. SUCH IMPROPER ACTIONS CAN DAMAGE THE SUPPORT BEAM ASSEMBLY AND CAUSE ADVERSE VEHICLE HANDLING AND POSSIBLE PERSONAL INJURY OR PROPERTY DAMAGE.

WARNING**WORK SITE DUMPING**

WHEN THE TRUCK/TRAILER BODY/BOOM/AND OR ATTACHMENT IS LIFTED IT IS MANDATORY TO COMPLETELY EXHAUST THE AIR FROM THE SUSPENSION SYSTEM TO HELP PROVIDE STABILITY WHEN LIFTED. FAILURE TO DO SO CAN RESULT IN ADVERSE VEHICLE HANDLING, ROLL-OVER, OR VEHICLE INSTABILITY, POSSIBLE PERSONAL INJURY, PROPERTY DAMAGE, OR DEATH. FIRST RAISE ANY AUXILIARY AXLES AND THEN EXHAUST ALL PRESSURE FROM REAR TRACTOR / TRAILER AND TRUCK AIR SUSPENSION SYSTEMS PRIOR TO RAISING THE BODY / BOOM OR ATTACHMENTS. FOLLOW THE VEHICLE MANUFACTURER'S OPERATING INSTRUCTIONS FOR MAINTAINING PROPER STABILITY.

CAUTION**AIR SPRING LOWER MOUNTING STUDS**

IF THE AIR SPRING IS BEING REMOVED FOR AN ALTERNATE REPAIR, IT IS MANDATORY TO LUBRICATE THE LOWER AIR SPRING FASTENERS WITH PENETRATING OIL AND REMOVE WITH HAND TOOLS TO PREVENT DAMAGE TO THE LOWER AIR SPRING MOUNTING STUD. FAILURE TO DO SO CAN CAUSE COMPONENT DAMAGE AND VOID WARRANTY.

WARNING**AIR SPRING PRESSURE RETENTION**

SOME VEHICLE APPLICATIONS, SUCH AS VEHICLES EQUIPPED WITH OUTRIGGERS, RETAIN SOME AIR PRESSURE IN THE AIR SPRINGS AT ALL TIMES. PRIOR TO PERFORMING ANY MAINTENANCE, SERVICE, OR REPAIR OF THE SUSPENSION, VERIFY EACH AIR SPRING IS COMPLETELY DEFLATED. FAILURE TO DO SO COULD RESULT IN SERIOUS PROPERTY DAMAGE AND/OR SEVERE PERSONAL INJURY.

WARNING

FAILURE TO PRESS THE AIR SPRING AGAINST THE UNDERSIDE OF THE FRAME WHILE TIGHTENING THE UPPER AIR SPRING BRACKET CAN RESULT IN COMPONENT DAMAGE AND PERSONAL INJURY OR PROPERTY DAMAGE.

WARNING**AIR SPRING INFLATION AND DEFLATION**

PRIOR TO DISASSEMBLY OF THE SUSPENSION, AIR SPRING ASSEMBLIES MUST BE DEFLATED. UNRESTRICTED AIR SPRING ASSEMBLIES CAN VIOLENTLY SHIFT. DO NOT INFLATE AIR SPRING ASSEMBLIES WHEN THEY ARE UNRESTRICTED. AIR SPRING ASSEMBLIES MUST BE RESTRICTED BY SUSPENSION OR OTHER ADEQUATE STRUCTURE. DO NOT INFLATE BEYOND PRESSURES RECOMMENDED BY AIR .MANUFACTURER, CONTACT HENDRICKSON TECHNICAL SERVICES FOR DETAILS. IMPROPER USE OR OVER INFLATION MAY CAUSE AIR SPRING ASSEMBLIES TO BURST, CAUSING PROPERTY DAMAGE AND/OR SEVERE PERSONAL INJURY.

PRIOR TO AND DURING DEFLATION AND INFLATION OF THE AIR SUSPENSION SYSTEM, ENSURE ALL PERSONNEL AND EQUIPMENT ARE CLEAR FROM UNDER THE VEHICLE AND AROUND THE SERVICE AREA, FAILURE TO DO SO CAN CAUSE SERIOUS PERSONAL INJURY, DEATH, OR PROPERTY DAMAGE.

CAUTION**AIR SPRING INFLATION**

INFLATE THE SUSPENSION SLOWLY AND MAKE SURE THE RUBBER BLADDER OF THE AIR SPRING INFLATES UNIFORMLY AND IS NOT BINDING. FAILURE TO DO SO CAN CAUSE DAMAGE TO THE AIR SPRING AND/OR MOUNTING BRACKETS AND VOID WARRANTY.



SHOCK ABSORBERS

THE SHOCK ABSORBERS ARE THE REBOUND TRAVEL STOPS FOR THE SUSPENSION. ANYTIME THE AXLE ON A PRIMAAX EX SUSPENSION IS SUSPENDED IT IS MANDATORY THAT THE SHOCK ABSORBERS REMAIN CONNECTED. FAILURE TO DO SO CAN CAUSE THE AIR SPRINGS TO SEPARATE FROM THE PISTON AND RESULT IN PREMATURE AIR SPRING FAILURE. REPLACEMENT OF SHOCK ABSORBERS WITH NON-HENDRICKSON PARTS CAN ALTER THE REBOUND TRAVEL OF THE SUSPENSION.



CROSS TUBE

IMPROPER JACKING METHODS CAN CAUSE STRUCTURAL DAMAGE (SEE SAFETY DECAL, FIGURE 3-1) AND RESULT IN ADVERSE VEHICLE HANDLING, SEVERE PERSONAL INJURY OR DEATH AND WILL VOID HENDRICKSON'S WARRANTY.

FIGURE 3-1 Safety Decal Number 60905-015

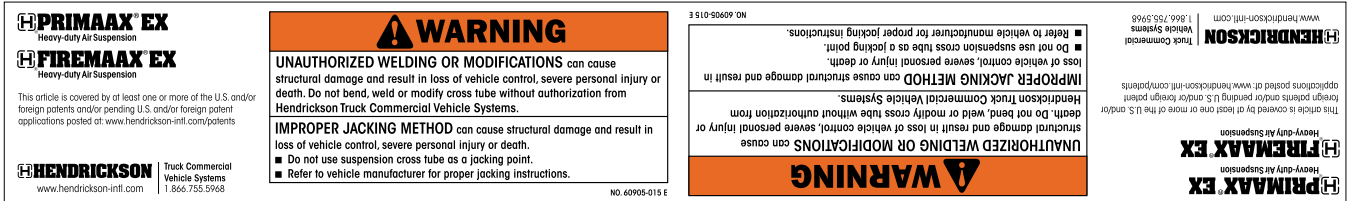

- REPLACE ANY SAFETY DECALS THAT ARE FADED, TORN, MISSING, ILLEGIBLE, OR OTHERWISE DAMAGED. CONTACT HENDRICKSON TO ORDER REPLACEMENT LABELS
- DO NOT USE THE SUSPENSION CROSS TUBE AS A JACKING POINT TO RAISE THE VEHICLE, SEE FIGURE 3-2
- REFER TO VEHICLE MANUFACTURER FOR PROPER JACKING INSTRUCTIONS, SEE FIGURE 3-3

FIGURE 3-2



FIGURE 3-3



PARTS CLEANING

SOLVENT CLEANERS CAN BE FLAMMABLE, POISONOUS, AND CAUSE BURNS. TO HELP AVOID SERIOUS PERSONAL INJURY, CAREFULLY FOLLOW THE MANUFACTURER'S PRODUCT INSTRUCTIONS AND GUIDELINES AND THE FOLLOWING PROCEDURES:

1. WEAR PROPER EYE PROTECTION.
2. WEAR CLOTHING THAT PROTECTS YOUR SKIN.
3. WORK IN A WELL-VENTILATED AREA.
4. DO NOT USE GASOLINE OR SOLVENTS THAT CONTAIN GASOLINE. GASOLINE CAN EXPLODE.
5. HOT SOLUTION TANKS OR ALKALINE SOLUTIONS MUST BE USED CORRECTLY. FOLLOW THE MANUFACTURER'S RECOMMENDED INSTRUCTIONS AND GUIDELINES CAREFULLY TO HELP PREVENT PERSONAL ACCIDENT OR INJURY.

DO NOT USE HOT SOLUTION TANKS OR WATER AND ALKALINE SOLUTIONS TO CLEAN GROUND OR POLISHED PARTS. DOING SO WILL CAUSE DAMAGE TO THE PARTS AND VOID WARRANTY.

SECTION 4 Special Tools

D-PIN / QUIK-ALIGN PIVOT BUSHING SERVICE TOOLS

Hendrickson Part No. 66086-202

OTC Part No. 4246 Visit otctools.com

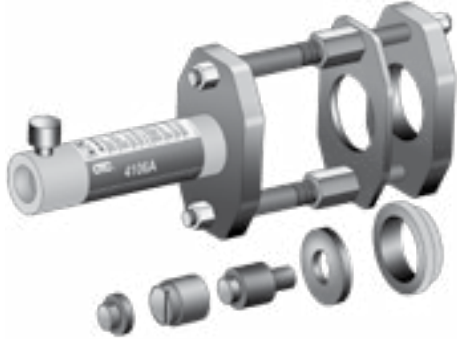

Hendrickson Part No. 66086-204

OTC Part No. 4247 Visit otctools.com

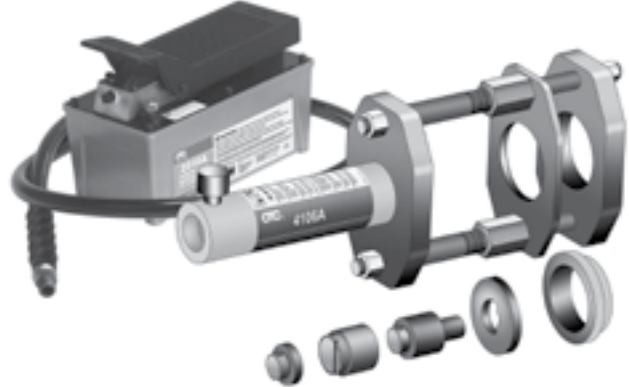

QUIK-ALIGN SOCKET TOOL

Hendrickson Part No. 66086-200

OTC Part No. 1767

Visit otctools.com



QUIK-ALIGN PIVOT BUSHING SERVICE TOOL

Hendrickson Part No. 66086-203L

Reference Hendrickson
Literature No. 59310-061

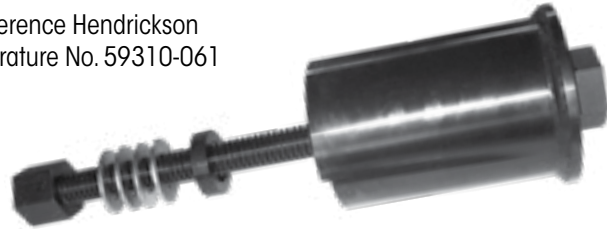



D-PIN / QUIK-ALIGN PIVOT BUSHING SHOP MADE SERVICE TOOLS

These shop made tools are designed to service D-pin and QUIK-ALIGN pivot bushings. These tools are made from cold rolled steel or equivalent. Drawings are for reference only. Hendrickson does not supply these tools.

QUIK-ALIGN TOOLS

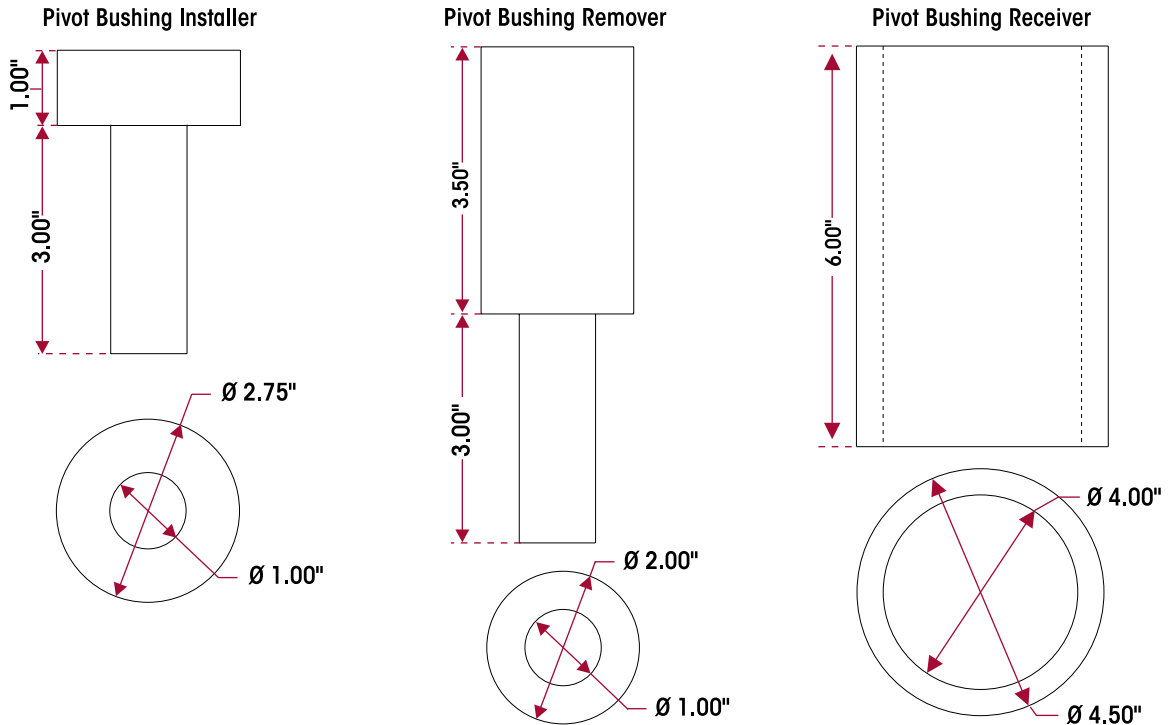

D-PIN TOOLS

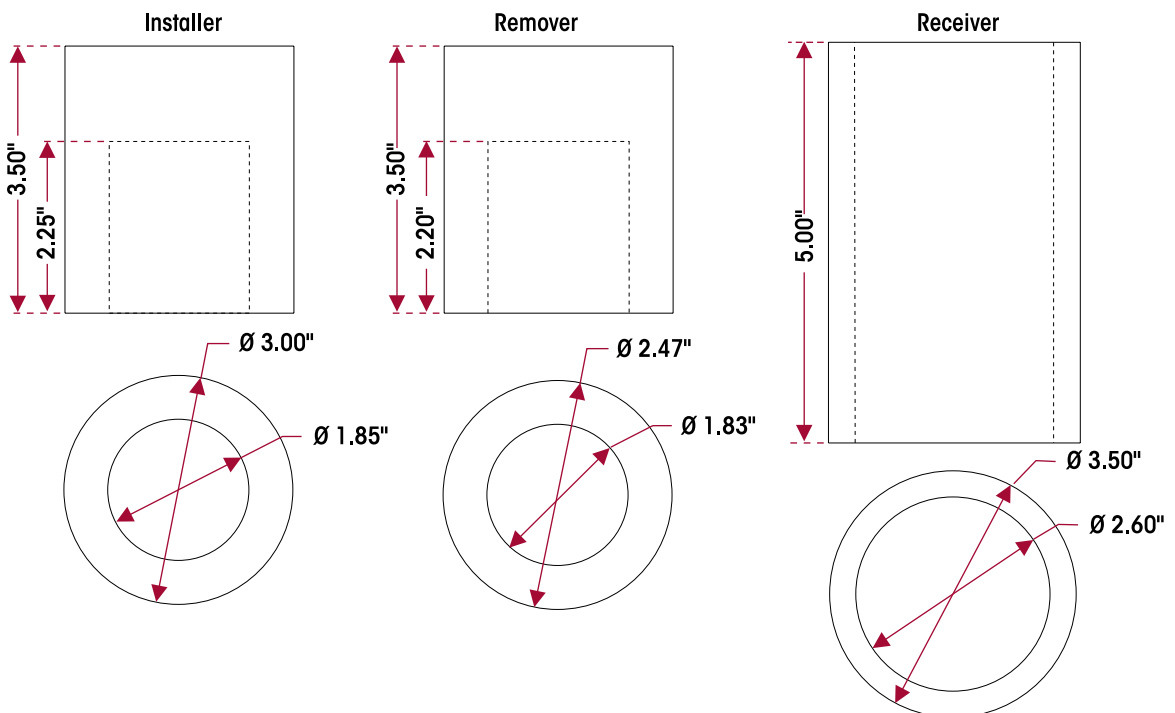



SECTION 5 Parts Lists

PRIMAAX EX 23K • 46K • 69K

8½" • 10" Ride Height
Vehicles built after April 2011

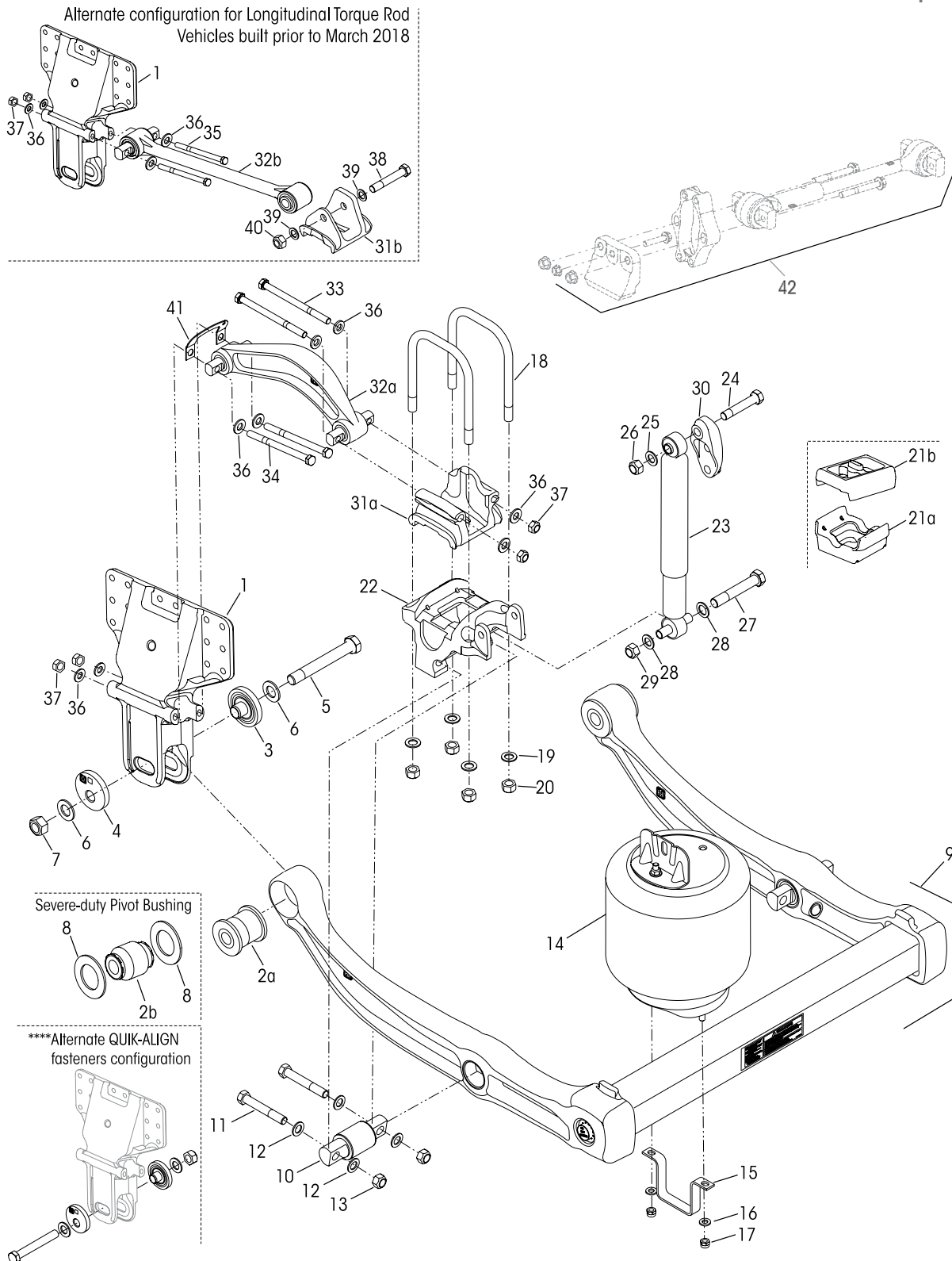



PRIMAAX® EX • PRIMAAX® Rear Air Suspension for Vovo Vehicles

KEY NO.	PART NO.	DESCRIPTION	VEHICLE QTY.
1	67222-002	Frame Hanger	4
		Pivot Bushing Service Kit	
	60961-720	One Wheel End , Includes Key Nos. 2a, 3-7, 43	
	60632-020	Axle Set , Includes Key Nos. 2a, 3-7, 43	
	60632-043	Axle Set , Severe-duty, Includes Key Nos. 2b, 3-8, 43	
		QUIK-ALIGN Collar Service Kit , Includes Key Nos. 3-7	
	60632-019	One Wheel End	
	60632-021	Axle Set	
	60632-018	QUIK-ALIGN Fastener Service Kit , One Wheel End , Includes Key Nos. 5-7	
2	a	*Heavy-duty Pivot Bushing	4
	b	*Severe-duty Pivot Bushing	4
3		*QUIK-ALIGN Concentric Collar	4
4		*QUIK-ALIGN Eccentric Collar	4
5		*1"-1.4 UNF x 7½" Hendrickson Coated Hex Bolt	4
6		*1" Hendrickson Coated Flat Washer	8
7		*1"-1.4 UNF Hendrickson Coated Locknut	4
8		*Confinement Washer	4
9		U-beam Assembly, Includes Key Nos. 2, 10	
	67249-003	Rear	1
	67249-004	Front	1
		D-pin Bushing Service Kits , See Selection Guide on Page 14	
	34013-XXX	Single , Includes Key Nos. 10-13	
	56659-XXX	Axle Set , Fasteners Only, Includes Key Nos. 11-13	
10		*D-pin Bushing	4
11		*¾"-1.6 UNF Bolt, See Selection Guide on Page 14	8
12		*¾" Flat Washer	16
13		*¾"-1.6 UNF Locknut	8
		Air Spring Service Kits	
	60961-230	One Wheel End , Includes Key Nos. 14-17	
	49177-006	Single , Fasteners only, Includes Key Nos. 16-17	
14	67043-002	Air Spring Assembly	4
15	60911-002	Lower Air Spring Mounting Bracket	4
16		*½" Flat Washer	8
17		*½"-1.3 UNC Locknut	8
		U-bolt Service Kit, One Wheel End , Includes Kit No. 48718-501	
		• Used with Key No. 31a	
	91430-048	8½" Ride Height, Includes Key Nos. 18a	
	91430-050	10" Ride Height, Includes Key Nos. 18b	
		• Used with Key No. 31b	
	91430-041	8½" Ride Height, Includes Key Nos. 18c	
	91430-044	10" Ride Height, Includes Key Nos. 18d	
18		*¾"-1.6 UNF Square U-bolt	8
	a	10¾" - 8½" Ride Height	
	b	9¾" - 10" Ride Height	
	c	10¾" - 8½" Ride Height	
	d	9¾" - 10" Ride Height	

KEY NO.	PART NO.	DESCRIPTION	VEHICLE QTY.
	48718-501	U-bolt Fastener Kit, One Wheel End Includes Key Nos. 19-20	
19		*¾" Flat Washer	16
20		*¾"-1.6 UNF U-bolt Locknut	16
21		Axle Spacer	4
	a	65139-003 8½" Ride Height, Lower	
	b	76960-001 10" Ride Height, Upper	
22	60556-XXX	Bottom Cap, See Selection Guide on Page 14	4
23		Shock Absorber	4
	60657-007	8½" Ride Height	
	60657-003	10" Ride Height	
	50754-030	Single Shock Absorber Fastener Service Kit , Includes Key Nos. 24-29	
24		*¾"-1.0 UNC x 4¼" Upper Shock Bolt	4
25		*¾" Flat Washer	4
26		*¾"-1.0 UNC Locknut	4
27		*⅝"-1.1 UNC X 6" Lower Shock Bolt	4
28		*⅝" Flat Washer	8
29		*⅝"-1.1 UNC Locknut	4
30	67463-006	Upper Shock Frame Bracket	4
31		Top Pad	4
	a	76961-000 • Use with Arched Style Torque Rod	
	b	• Use with Thru Bolt Style Torque rod	
	60877-001	8½" Ride Height	
	65641-000	10" Ride Height	
32		Longitudinal Torque Rod, See Selection Guide on Page 14	4
	a	Arched Style	
	b	67274-XXX Thru Bolt Style, Replaces 64981-XXX	
		Longitudinal Torque Rod Fastener Service Kits, One Side	
	49176-060	To Top Pad, Includes Key Nos. 33, 36-37	
	49176-050	To Frame Hanger, Includes Key Nos. 34, 36-37	
	58821-027	To Frame Hanger, Includes Key Nos. 35-37	
	58821-012	To Top Pad, Includes Key Nos. 38-40	
33		*⅝"-1.1 UNC x 5½" Hex Bolt	8
34		*⅝"-1.1 UNC x 10½" Hex Bolt or **M16 x 2-6G Bolt	8
35		*⅝"-1.1 UNC x 8" Hex Bolt or **M16 x 2-6G Bolt	8
36		*⅝" Flat Washer or **M16 Washer	32
37		*⅝"-1.1 UNC Locknut or **M16 x 2-6H Locknut	16
38		*⅞"-1.4 UNF-2A x 5½" Hex Bolt	4
39		*⅞" Flat Washer	8
40		*⅞"-1.4 UNF-2B Locknut	4
41		Torque Rod Shim, See Selection Guide on Page 14	As Req.
	70240-001	3.0 mm,	
	70240-002	1.5 mm	
42		**Transverse Torque Rod Assembly	2
43	70867-001	P-80 Lubricant - 10 ml (Not Shown)	Per Bushing
Not Shown		**Height Control Valve and Linkage Assembly	1

NOTES: Quantities specified are shown for a tandem suspension. Adjust quantities for single or tridem suspensions. Quantities of service kit components may vary from the amount shown in lists.

* Item included in kit/assembly only, part not sold separately.

** Item required, component supplied by the vehicle manufacturer. Hendrickson is not responsible for components not supplied by Hendrickson, for assistance with maintenance and rebuild instructions on these components see the vehicle manufacturer.

*** No longer available for service, see replacement guide on Page 13. For more information, refer to Hendrickson Technical Bulletin Literature No. SEU-0229 or contact Hendrickson Tech Services.

**** Alternate configuration of the QUIK-ALIGN fasteners. The locknuts located inboard will allow additional clearance for wider tires or tires with chains. Tightening is still required ONLY on the locknut.



PRIMAAX 230 • 460 • 690
Equipped with Drum Brakes

8½" • 10" Ride Height
Vehicles built prior to April 2011

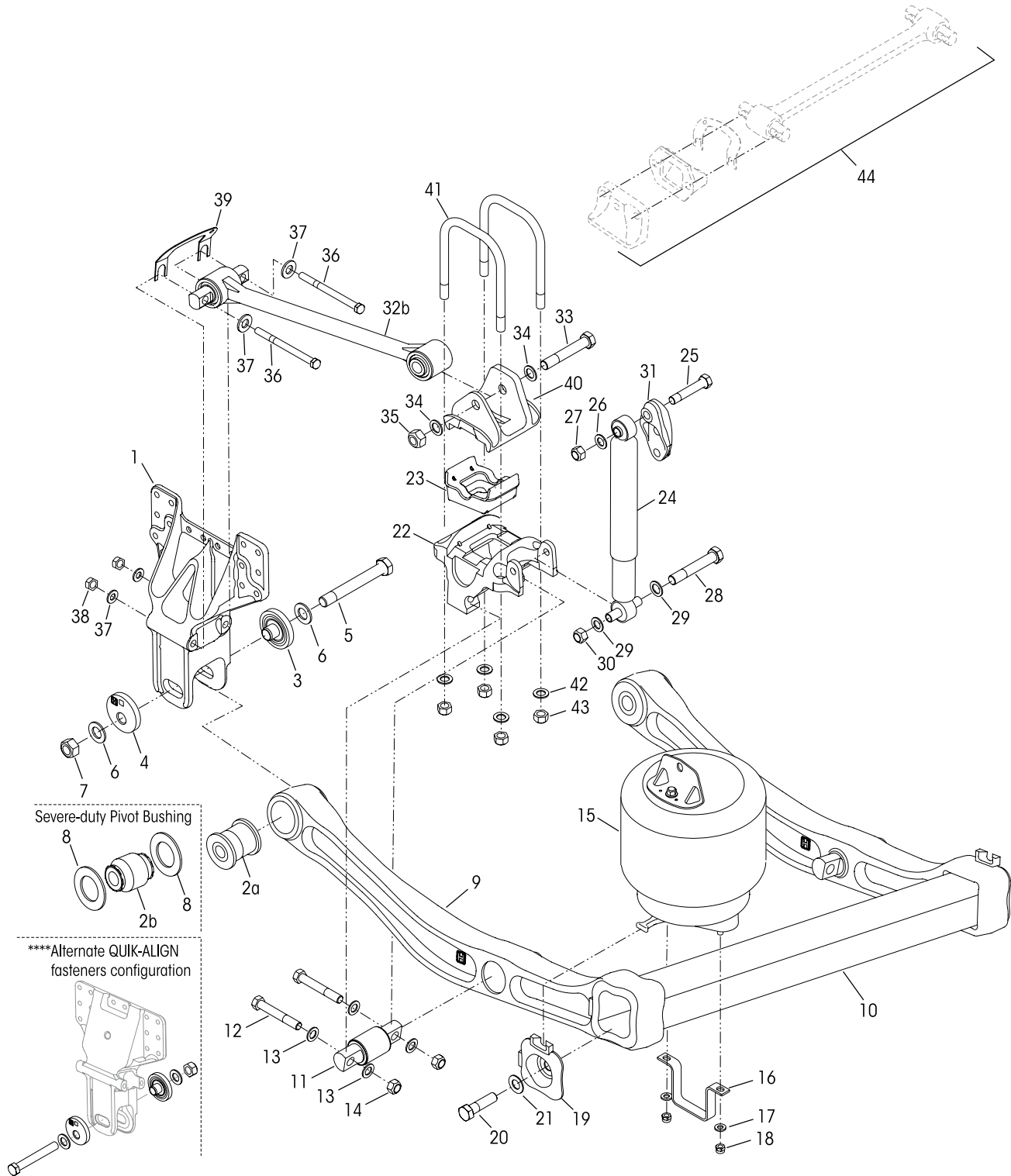



KEY NO.	PART NO.	DESCRIPTION	VEHICLE QTY.
1	67222-000	Frame Hanger, <i>Replaces 65702-001</i>	4
		Pivot Bushing Service Kit	
	60961-720	One Wheel End , Includes Key Nos. 2a, 3-7, 45	
	60632-020	Axle Set , Includes Key Nos. 2a, 3-7, 45	
	60632-043	Axle Set , Severe-duty, Includes Key Nos. 2b, 3-8, 45	
		QUIK-ALIGN Collar Service Kit , Includes Key Nos. 3-7	
	60632-019	One Wheel End	
	60632-021	Axle Set	
	60632-018	QUIK-ALIGN Fastener Service Kit, One Wheel End , Includes Key Nos. 5-7	
2	a	*Heavy-duty Pivot Bushing	4
	b	*Severe-duty Pivot Bushing	4
3		*QUIK-ALIGN Concentric Collar	4
4		*QUIK-ALIGN Eccentric Collar	4
5		*1"-14 UNF x 7½" Hendrickson Coated Hex Bolt	4
6		*1" Hendrickson Coated Flat Washer	8
7		*1"-14 UNF Hendrickson Coated Locknut	4
8		*Confinement Washer	4
9		***Support Beam Assembly, <i>60831-</i> , see <i>Replacement Guide below</i>	
10		***Cross Tube, <i>60912-005</i> , see <i>Replacement Guide below</i>	
		D-pin Bushing Service Kits	
	34013-107	Single , Includes Key Nos. 11-14	
	56659-009	Axle Set , Fasteners Only, Includes Key Nos. 12-14	
11		*D-pin Bushing	4
12		*¾"-16 UNF x 5" Bolt	8
13		*¾" Flat Washer	16
14		*¾"-16 UNF Locknut	8
		Air Spring Service Kits	
	60961-062	One Wheel End , Includes Key Nos. 15-18	
	49177-006	Single , Fasteners only, Includes Key Nos. 17-18	
15	60271-002	Air Spring Assembly	4
16	60911-000	Lower Air Spring Mounting Bracket	4
17		*½" Flat Washer	8
18		*½"-13 UNC Locknut	8
	46772-001	End Cap and Fastener Kit, Axle Set , Includes Key Nos. 19-21	
19		*End Cap	4

KEY NO.	PART NO.	DESCRIPTION	VEHICLE QTY.
20		*¾"-9 UNC x 3½" Hex Bolt	4
21		*¾" Flat Washer	4
22	60556-XXX	Bottom Cap, <i>See Selection Guide on Page 14</i>	4
23	65139-003	Axle Spacer	4
24	60657-007	Shock Absorber, 8½" Ride Height	4
	50754-030	Single Shock Absorber Fastener Service Kit , Includes Key Nos. 25-30	
25		*¾"-10 UNC x 4¼" Upper Shock Bolt	4
26		*¾" Flat Washer	4
27		*¾"-10 UNC Locknut	4
28		*⅝"-11 UNC X 6" Lower Shock Bolt	4
29		*⅝" Flat Washer	8
30		*⅝"-11 UNC-2B Locknut	4
31	67463-006	Upper Shock Frame Bracket, <i>Replaces 65000-006</i>	4
32b	67274-XXX	Longitudinal Torque Rod, <i>Replaces 64981-XXX</i> <i>See Selection Guide on Page 14</i>	4
		Longitudinal Rod Fastener Service Kits, One Side	
	58821-012	To Top Pad, Includes Key Nos. 33-35	
	58821-027	To Frame Hanger, Includes Key Nos. 36-38	
33		*⅞"-14 UNF-2A x 5½" Hex Bolt	4
34		*⅞" Flat Washer	8
35		*⅞"-14 UNF-2B Locknut	4
36		*⅝"-11 UNC x 8" Hex Bolt or **M16 x 2-6G Bolt	8
37		*⅝" Flat Washer or **M16 Washer	16
38		*⅝"-11 UNC Locknut or **M16 x 2-6H Locknut	8
39		Torque Rod Shim	As Req.
	70240-001	3.0 mm	
	70240-002	1.5 mm	
40	60877-001	Top Pad	4
	91430-041	U-bolt Service Kit, One Wheel End , Includes Key No. 25 & Kit No. 48718-501	
41		*¾"-16 UNF x 10⅝" U-bolt	8
	48718-501	U-bolt Fastener Kit, One Wheel End , Includes Key Nos. 26-27	
42		*¾" Flat Washer	16
43		*¾"-16 UNF U-bolt Locknut	16
44		**Transverse Torque Rod Assembly	2
45	70867-001	P-80 Lubricant - 10 ml (Not Shown) Per Bushing	1
		Not Shown	**Height Control Valve and Linkage Assembly

■ Support Beam and Cross Tube Replacement Guide

Drive Axle	DISCONTINUED		Cross Tube Part No.	NEW	COMMENTS
	Support Beam Assembly Part No. Left Hand	Support Beam Assembly Part No. Right Hand		U-beam Assembly Replacement Kit No.	
Forward	60831-003	60831-004	60912-005	60961-237	Each U-beam assembly replacement kit is intended to service the associated suspension parts on one axle. It includes two new support beam assemblies, one cross tube, two air spring assemblies, air spring fasteners, QUIK-ALIGN fasteners and D-pin fasteners.
Rear	60831-001	60831-002		60961-238	



■ Bottom Cap, Longitudinal Torque Rod Selection Guide

Vehicles Equipped with Air Disc Brakes

	◆Pinion Angle	Brake Clocking		Key No. 11			Key No. 22	Key No. 32a	Key No. 41		
		Ride Height		D-pin Bolt Length	D-pin Bushing Service Kit No.	D-pin Fasteners Service Kit No.	Bottom Cap Part No.	◆◆Longitudinal Torque Rod (Arched Style) Part No.	Torque Rod Shims		
		8½"	10"						8½"	10"	
FRONT	1.5°	92°	84°	4¾"	34013-117	56659-012	60556-025	67219-435	3 mm	3 mm	
	2.5°						60556-035		4 mm	4 mm	
	4°			60556-050	6 mm	5 mm					
	6°	95°		5½"	34013-116	56659-013	60556-845	77128-435	6 mm	6 mm	
	7°			6"	34013-200	56659-024			60556-855	6 mm	6 mm
REAR	9°	95°	90°	4¾"	34013-117	56659-012	60556-805	68801-205	6 mm	5 mm	
	9.5°						60556-810		4 mm	3.0 mm	
	10°			5"	34013-107	56659-009	60556-820		5 mm		6 mm
	10.5°						60556-825				
	11°			5½"	34013-201	56659-014	60556-830		6 mm	4 mm	
	11.5°						60556-835				
	12°			5½"	34013-116	56659-013	60556-840		60556-845	6 mm	4 mm
	12.5°						60556-845				

Vehicles Equipped with Drum Brakes

	◆Pinion Angle		Key No. 11			Key No. 22	Key No. 32b
	8½" Ride Height	10" Ride Height	D-pin Bolt Length	D-pin Bushing Service Kit No.	D-pin Fasteners Service Kit No.	Bottom Cap Part No.	◆◆Longitudinal Torque Rod (Thru Bolt Style) Part No.
FRONT	2.9°	2.9°	4¾"	34013-117	56659-012	60556-025	67274-530
	6.0°	6.1°	5¼"	34013-201	56659-014	60556-060	
	7.9°	8.2°	5"	34013-107	56659-009	60556-120	67274-550
REAR	10.3°	9.8°	4¾"	34013-117	56659-012	60556-100	67274-575
	10.7°	10.2°				60556-105	
	11.2°	10.7°				60556-110	
	11.6°	11.2°				60556-115	
	12.1°	11.6°	5"	34013-107	56659-009	60556-120	
	13.0°	12.6°	5¼"	34013-201	56659-014	60556-130	
13.4°	13.1°	60556-135					

NOTES: ◆ Measured with QUIK-ALIGN pinion set at neutral position (12 O'Clock)

◆◆ Torque rod bushings are non-serviceable, replacement requires complete torque rod assembly with bushings.



SECTION 6 Preventive Maintenance

Following appropriate inspection procedure is important to help ensure the proper maintenance and operation of the PRIMAAX EX • PRIMAAX rear air suspension system and components function to their highest efficiency.

NOTE Torque values shown of this publication apply only if Hendrickson supplied fasteners are used. If non-Hendrickson fasteners are used, follow the torque specification listed in the vehicle manufacturer's service manual.

AREAS OF INSPECTION

- Air springs
- Air supply and fittings
- All fasteners
- D-pin and Pivot Bushings
- Clamp group: Top pad, U-bolts and locknuts
- Frame hanger bracket
- Height control valve
- Longitudinal torque rods
- QUIK-ALIGN connections
- Shock absorbers
- Tire wear
- Transverse torque rods
- U-beam assembly: Cross tube to support beam connection

■ Signifies performance critical components group

HENDRICKSON RECOMMENDED INSPECTION INTERVALS

Visually inspect the proper assembly and function. Check for all of the following and replace components as necessary:

- Signs of unusual movement, loose or missing components
- Signs of abrasive or adverse contact with other components
- Damaged, or cracked parts
- Improper suspension function or alignment

Visually inspect the overall condition of and for any signs of damage to:

- U-beam assembly
- Air springs and air lines
- Torque rods

Inspect all fasteners for proper torque as recommended in the Torque Specifications section of this publication:

- **DO NOT** re-torque Integrated End Cap, see Figure 6-1
- Clamp group U-bolt fasteners, see Figure 6-2
- QUIK-ALIGN fasteners and torque rod to the top pad fasteners

Verify the lateral alignment of the drive axles are within the vehicle manufacturer's tolerances.

Verify ride height. Refer to the vehicle manufacturer for proper specifications and procedure.

PRE-DELIVERY INSPECTION	FIRST IN-SERVICE INSPECTION	PREVENTIVE MAINTENANCE
Within the first 500 miles (800 km)	Within the first 1,000 miles (1,600 km) or 100 hours	Off-highway every 6 months / 1,200 hours or 25,000 miles / 40,000 km, whichever comes first
		On-highway every 12 months / 50,000 miles, whichever comes first
		Every 12 months / 2400 hours

See vehicle manufacturer's applicable publications for other preventive maintenance requirements.



COMPONENT INSPECTION

IMPORTANT NOTE

Replace all worn or damaged parts.

- **Air spring** — Visually inspect the outer surface of the air spring for chafing, uneven wear, cracks or any signs of component damage. Ensure that the upper bead plate is tight against the underside of the frame. Check for any lateral slippage at the lower air spring bracket. An $\frac{1}{8}$ " of slippage in either direction is acceptable. Verify all mounting hardware have the proper torque values maintained. See the Torque Specifications section in this publication for recommended torque requirements.
- **Air supply (Pneumatic components)** — The air supply to the system plays a large role in the air springs' performance. Inspect, clean and replace, if necessary, any support products to the air springs, valves, regulators and air lines. See Air Fittings in this section for proper inspection.
- **Clamp group** — Visually inspect for any loose or damaged fasteners. Verify the U-bolt locknuts have the proper torque values maintained. See the U-bolt Locknuts in this section.
- **Cross tube** — Visually inspect for cracks, damage, metal shavings, or looseness at the beam connection.
- **Fasteners** — Visually inspect for any loose or damaged fasteners on the entire suspension. Make sure all fasteners are tightened to a torque value within the specified torque range. See Torque Specifications section in this publication for recommended torque requirements. Use a calibrated torque wrench to check torque in a tightening direction. As soon as the fastener starts to move, record the torque and correct the torque if necessary.
- **Frame hanger** — Visually inspect for any signs of loose fasteners, movement, or damage. Verify the frame attaching fasteners have the proper torque values maintained. See the vehicle manufacturer for proper torque specifications.
- **Height control valve and air lines** — Check the suspension air system for air leaks. Check all air lines for proper routing. Check for chafing or pinched air lines. Check the height control valve linkage for damage or interference with peripheral components.
- **QUIK-ALIGN connection** — Visually inspect the connection for signs of looseness or movement. Visually inspect the bushing for wear. Verify the connections have the proper torque values maintained. See the Torque Specifications section in this publication for recommended torque requirements.
Refer to QUIK-ALIGN Fasteners Warnings in the Important Safety Notice section in this publication prior to installing QUIK-ALIGN connection.
- **Shock absorbers** — Visually inspect for any signs of dents or leakage. Misting is not considered a leak, see Shock Absorbers in this section for proper inspection.
- **Tire wear** — Visually inspect the tires for wear patterns that may indicate suspension damage or misalignment.
- **Top pad/Longitudinal torque rod connection** — Visually inspect the connection for signs of movement or damage. Use a lever check to help assess movement in this joint, see Longitudinal and Transverse Torque Rods in this section for proper inspection. Verify the top pad/longitudinal torque rod connections have the proper torque values maintained. See the Torque Specifications section in this publication for recommended torque requirements.
- **Torque rods (longitudinal and transverse)** — All torque rods must be inspected for looseness, torn or shredded rubber and for proper fastener torque, see Longitudinal and Transverse Torque Rod inspection in this section.
- **U-beam assembly** — Visually inspect the overall condition of the support beam for dents, dings, or other damage on the outer edges of the beam flanges. Visually inspect the D-pin bushings for tearing or extreme bulging. Check for any metal-to-metal contact in the bushed joints.
- **Wear and damage** — Visually inspect all parts of the suspension for wear and damage. Look for bent or cracked parts.



U-BOLT FASTENERS

NOTE U-bolt clamp group hardware for the PRIMAAX EX • PRIMAAX suspensions are 3/4"-16 UNF Grade C locknuts and 3/4"-16 UNF Grade 8 U-bolts which are phosphate and oil coated.

1. U-bolt locknuts must be torqued to specification at preparation for delivery.
2. U-bolt locknuts must be re-torqued at 1,000 miles.
3. Thereafter, follow the inspection and re-torque intervals below:
 - **Off-highway and severe service** – Every 25,000 miles or 6 months, whichever comes first
 - **100% On-highway** – Every 50,000 miles or 12 months, whichever comes first

Off-highway and severe service operating conditions require more frequent inspections than on-highway service operation.

SERVICE HINT Due to certain pinion angle configurations, the removal of the D-pin bolts may be necessary to access the U-bolt locknuts, see Figure 6-1.



WARNING THE U-BOLT CLAMP GROUP CONNECTION MUST BE PROPERLY ALIGNED AND HAVE THE PROPER TORQUE VALUES MAINTAINED. METAL SURFACES CAN WORK AND WEAR AGAINST OTHER RELATED CLAMP GROUP COMPONENTS IF NOT PROPERLY ALIGNED OR PROPERLY TIGHTENED TO MAINTAIN THE PROPER CLAMP FORCE. FAILURE TO DO SO CAN CAUSE PREMATURE COMPONENT WEAR, POSSIBLE SEPARATION OF THE CLAMP GROUP, CAUSING ADVERSE VEHICLE HANDLING, PROPERTY DAMAGE, OR PERSONAL INJURY.

FIGURE 6-1
Clamp Group &
D-pin Fasteners

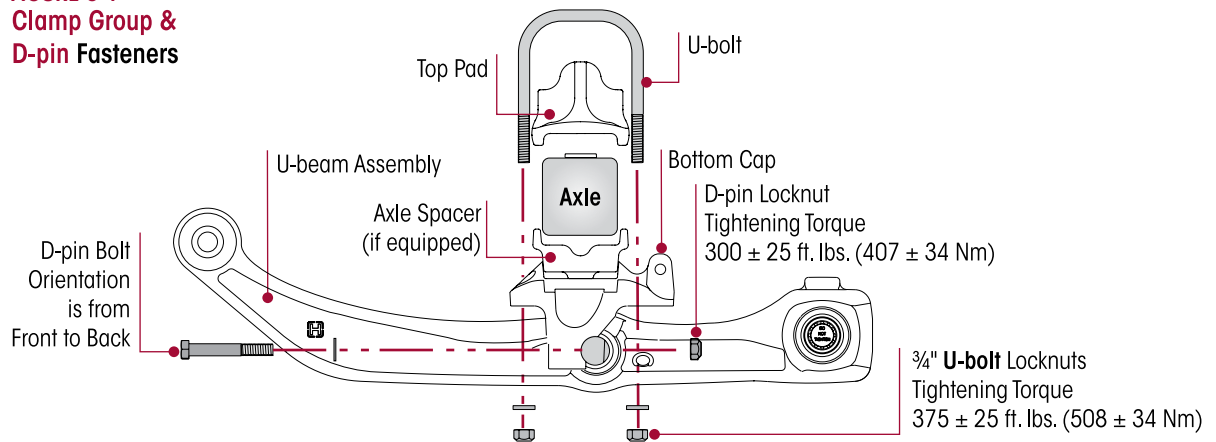

4. Tighten the U-bolt locknuts evenly in 50 foot pounds increments to 375 ± 25 foot pounds torque in the proper pattern to achieve uniform bolt tension, see Figures 6-2.

FIGURE 6-2

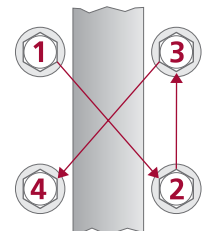

AIR FITTINGS

INSPECTION

1. If an air leak is suspected, begin the inspection by building up the air system to normal operating pressure.
2. Spray all nylon tube air fittings with a soapy water solution to detect the leak location.

NOTE Air lines and fittings may be inspected for leaks using a soapy water solution. The height control valve, however, cannot be inspected using this method. All height control valves have an allowable leakage rate.

3. If an air leak is located, ensure the tubing end is clean and in good condition and the end is cut square. Check to see if the tubing is binding, bent, or being pulled upon.
4. Visually inspect the air fitting's O-ring seal for signs of damage or contamination.

WARNING
QUIK-ALIGN PIVOT BUSHING AND D-PIN BUSHING

THE QUIK-ALIGN PIVOT BUSHING AND THE D-PIN BUSHING ARE CRITICAL COMPONENTS OF THE PRIMAAX EX • PRIMAAX SUSPENSIONS. IF ANY SUCH COMPONENTS APPEAR DAMAGED OR WORN THE COMPONENT MUST BE REPLACED. FAILURE TO REPLACE SUCH WORN OR DAMAGED COMPONENTS CAN RESULT IN THE DEFORMATION OF PARTS, LOSS OF CLAMP FORCE, BOLT FAILURE, LOSS OF THE AXLE ALIGNMENT, ADVERSE VEHICLE HANDLING, PROPERTY DAMAGE, OR PERSONAL INJURY.

There are two types of pivot bushing inspections for the PRIMAAX EX • PRIMAAX suspensions. The pivot bushing can be visually inspected by looking at the outer rubber flange(s) of the bushing. If the visual inspection warrants, a physical inspection can be conducted in which disassembly is required.

■ QUIK-ALIGN PIVOT BUSHING
VISUAL INSPECTION

It is not necessary to disassemble the pivot bushing connection to perform the pivot bushing visual inspection. If the pivot bushing rubber flange(s) are intact and there are no signs of metal to metal contact the bushing does not require replacement.

FIGURE 6-3
VISUAL INSPECTION – Torn, Disconnected or Missing Rubber Flange

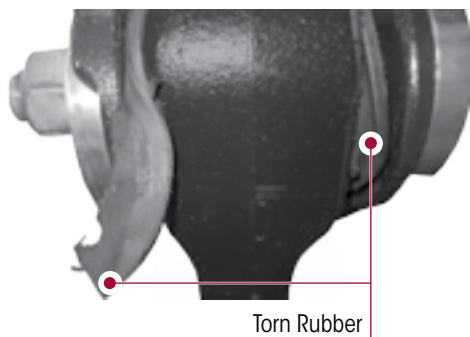

FIGURE 6-4

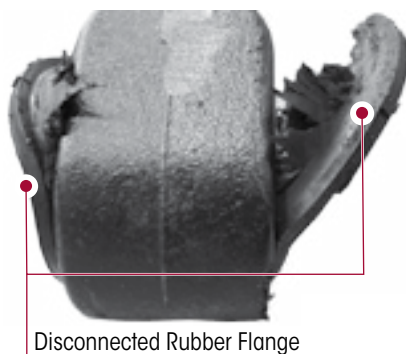

FIGURE 6-5



- The U-beam is designed with the pivot bushing centered in the U-beam end hub. If the pivot bushing is not centered in the end hub, it is an indication that the pivot bushing could be worn and a pivot bushing physical inspection is required.
- If the pivot bushing shows signs of torn, separated, or disconnected rubber, see Figures 6-3 and 6-4, this could be a result of axle misalignment. If this condition is evident, a pivot bushing physical inspection is required.
- If the outer rubber flange(s) is missing, or there are shards of rubber visible, see Figure 6-5, this could be a result of axle misalignment. If this condition is evident, pivot bushing replacement is required.

FIGURE 6-6
GOOD JOINT – No Replacement Needed

PHYSICAL INSPECTION

1. Remove the U-beam assembly as detailed in the Component Replacement section of this publication.
2. After removal, inspect the pivot bushing connection, examine the pivot bushing inner metal area.

- **No replacement is needed** if the bushing exhibits a tight joint, see Figure 6-6. An imprinted two-line wear pattern on the bushing inner metal indicates the pivot bushing is securely clamped in the frame hanger.

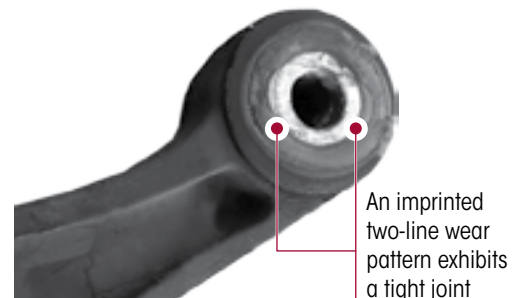

- **Replacement is necessary** if any indications of the following are apparent, see Figure 6-7: Signs of rust, distorted, separated or torn rubber, elongated or damaged bore. This could be a result of axle misalignment or loose fasteners.

FIGURE 6-7
PHYSICAL INSPECTION – Indications of a Loose Joint

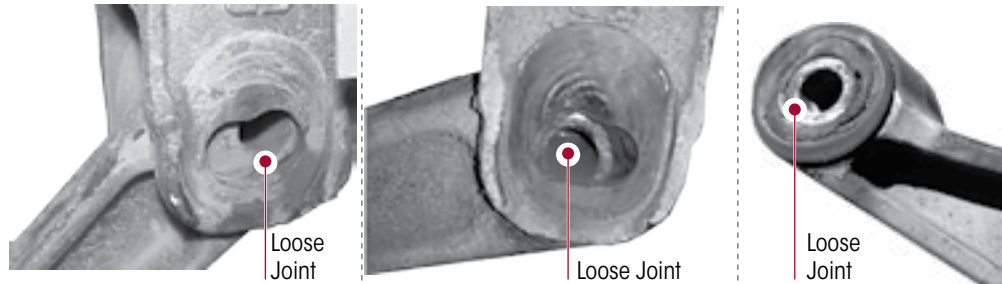

3. Inspect the inside of the frame hanger legs and the QUIK-ALIGN collars. If any of the following are present, the pivot bushing and one (1) or more of the mating components may require replacement:
 - Evidence of wear marks on the inside of the frame hanger legs indicating metal to metal contact or movement
 - The snout of the QUIK-ALIGN concentric or eccentric collar is elongated or damaged
4. Check the suspension alignment and adjust if necessary. Refer to Alignment & Adjustments section of this publication.

■ D-PIN BUSHING

VISUAL INSPECTION

It is not necessary to disassemble the D-pin connection to perform a D-pin visual inspection. The D-pin bushing is designed with a layer of rubber in the bushing, it is acceptable to see a bead of rubber protruding from the bushing, see Figure 6-8.

D-pin bushing replacement is **required** only when:

- Metal to metal contact wear marks on the D-pin outer metal are evident, see Figure 6-9
- D-pin outer metal is distorted, see Figure 6-9

Refer to the D-pin Component Replacement section of this publication.

FIGURE 6-8

ACCEPTABLE D-PIN

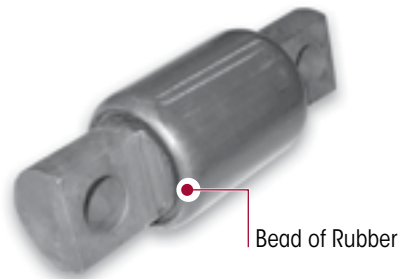
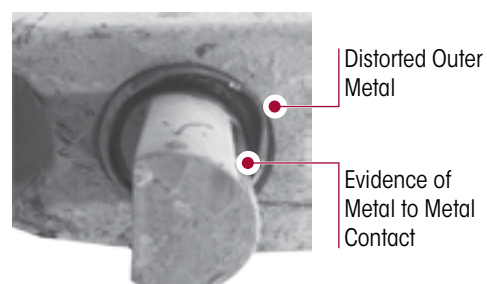

FIGURE 6-9

UNACCEPTABLE D-PIN



WARNING

LONGITUDINAL AND TRANSVERSE TORQUE RODS

THIS HENDRICKSON SUSPENSION REQUIRES TORQUE RODS FOR SUSPENSION PERFORMANCE AND VEHICLE STABILITY. IF THESE TORQUE RODS ARE DISCONNECTED OR ARE NON-FUNCTIONAL, DO NOT OPERATE THE VEHICLE. OPERATING A VEHICLE WITH DISCONNECTED OR NON-FUNCTIONAL TORQUE RODS CAN RESULT IN ADVERSE VEHICLE HANDLING, COMPONENT DAMAGE, SUSPENSION/VEHICLE DAMAGE, AND/OR SEVERE PERSONAL INJURY.

VISUAL INSPECTION

All torque rods equipped on the PRIMAAX EX • PRIMAAX suspensions need to be inspected during preventive maintenance and service for looseness by one of the following methods.

Torque rod looseness inspection is necessary per one of the following methods.

- **Method 1** — Due to visibility, this procedure is for **ONLY on-highway tractor applications**. With the brakes applied, slowly rock the empty vehicle with power while a second technician visually checks the action at both ends.
- **Method 2** — with the vehicle shut down, a lever check can be made with a long pry bar placed under each rod end and pressure applied

Visually inspect (1) **torque rod bushings** for any torn or shredded rubber material interfaces or elongated oval shapes and (2) **torque rods** for any metal to metal contact, bent, cracked, or broken components. The torque rod and/or the torque rod bushings will require replacement if any of these conditions are encountered.

- **Longitudinal torque rod length** is determined by the original vehicle manufacturer for optimum driveline angle(s). The longitudinal torque rods along with the bottom caps maintain these angles and control acceleration and brake forces, refer to the proper Selection Guide in the Parts Lists section of this publication.
 - **Arched style or through bolt style** longitudinal torque rods are non-rebushable. The entire torque rod assembly must be replaced. This feature provides superior bushing retention in the torque rod end hub.

FIGURE 6-10
Arched Style Torque Rods for
Vehicles built **after March 2018**

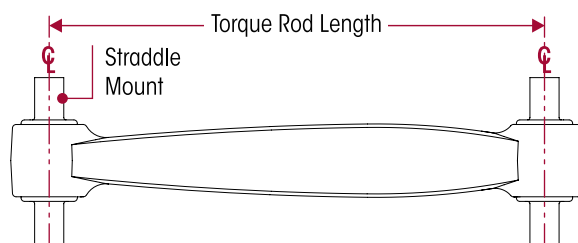
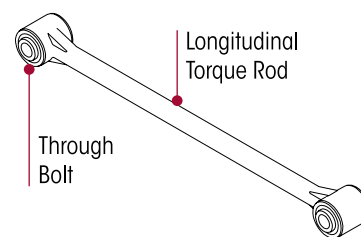

FIGURE 6-11
Alternate configuration for
Vehicles built **prior to March 2018**



- **Transverse torque rods** are supplied by vehicle manufacturer. Hendrickson is not responsible for components not supplied by Hendrickson, for assistance with maintenance and rebuild instructions on these components see vehicle manufacturer.

NOTE

It is important that the **tightening torque** of the locknuts be checked during preventive maintenance and service. Follow the tightening torque specifications and all applicable preventive maintenance, service, and safety instructions issued by the respective vehicle and suspension manufacturers.

NOTE

Hendrickson recommends the use of Grade 8 bolts and Grade C locknuts for all straddle mount torque rod attachments.



SHOCK ABSORBER

NOTE

It is not necessary to replace shock absorbers in pairs if only one (1) shock absorber requires replacement.

Hendrickson uses a long service life, premium shock absorber on all PRIMAAX EX • PRIMAAX suspensions. When the shock absorber replacement is necessary, Hendrickson recommends that the shock absorbers be replaced with identical Hendrickson Genuine parts for servicing. Failure to do so will affect the suspension performance, durability, and will void any applicable warranty. See vehicle manufacturer's applicable publications for other shock absorber inspection requirements.

Inspection of the shock absorber can be performed by doing a heat test, and a visual inspection. Replace as necessary, refer to the Component Replacement section of this publication.

FIGURE 6-12



HEAT TEST AND PHYSICAL INSPECTION



WARNING

DO NOT GRAB THE SHOCK ABSORBER AS IT COULD POSSIBLY BE HOT AND CAUSE PERSONAL INJURY.

1. **Heat Test:** Drive the vehicle with the lift axle down (if equipped) at moderate speeds on a rough road for a minimum of fifteen minutes.
 - a. Perform a heat test by carefully touching or placing a hand near the shock absorber body below the dust cover. Touch the frame to get an ambient reference, see Figure 6-12. A shock absorber that is warm to the touch is acceptable, a cold shock absorber should be replaced.
2. **Physical Inspection:** To inspect for an internal failure, remove and shake the suspected shock absorber. Listen for the sound of metal parts rattling inside. The rattling of metal parts can indicate that the shock absorber has an internal failure and the shock absorber should be replaced.

VISUAL INSPECTION

Look for these potential problems when doing a visual inspection, see Figure 6-13. Inspect the shock absorbers fully extended. Replace as necessary.

FIGURE 6-13

SHOCK ABSORBER VISUAL INSPECTION – UNACCEPTABLE CONDITIONS



Damaged upper or lower mount



Damaged upper or lower bushing



Damaged dust cover and / or shock body



Bent or dented shock absorber



Improper installation
Example: washer (if equipped) installed backwards

LEAKING VS. MISTING INSPECTION

The inspection must not be conducted after driving in wet weather or a vehicle wash. The shock absorber needs to be free from water.

Many shock absorbers are often misdiagnosed as failures. Misting is the process whereby very small amounts of shock absorber fluid evaporate at a high operating temperature through the upper seal of the shock absorber. When the "mist" reaches the cooler outside air, it condenses and forms a film on the outside of the shock absorber body. Misting is perfectly normal and a necessary function of the shock absorber. The fluid which evaporates through the seal area helps to lubricate and prolong the life of the seal.

NOTE

The PRIMAAX EX • PRIMAAX system is equipped with a premium seal on the shock absorber, however, this seal will allow for misting to appear on the shock absorber body (misting is not a leak and is considered acceptable).

Inspect the shock absorber fully extended. **A shock absorber that is truly leaking** will show signs of fluid **leaking in streams from the upper seal**, see Figure 6-14. These streams can easily be seen, underneath the main body (dust cover) of the shock absorber. Replace as necessary.

FIGURE 6-14

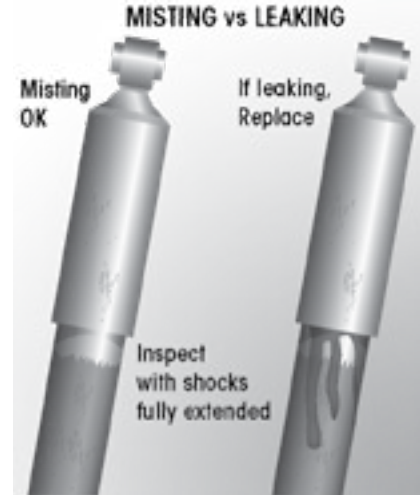



SECTION 7

Alignment & Adjustments

RIDE HEIGHT

PRIMAAX EX / PRIMAAX suspensions for Volvo vehicles are equipped with a height control valve located on the front drive axle. The height control valve is not supplied by Hendrickson, although it is a required component. Hendrickson is not responsible for components supplied by the vehicle manufacturer. For assistance with inspection, adjustments, maintenance, replacement and rebuild instructions on these components, refer to the vehicle manufacturer.

DRIVE AXLE ALIGNMENT INSPECTION

Proper alignment is essential for maximum ride quality, performance, and tire service life, the recommended alignment procedure is described below. This procedure should be performed if excessive or irregular tire wear is observed, or any time the QUIK-ALIGN connection is loosened or removed.

1. Use a work bay with a level surface.
2. Relax the suspension by slowly moving the vehicle back and forth several times in a straight line without using the brakes. This will slacken or loosen the suspension as the vehicle is positioned. End with all wheels positioned straight ahead.
3. **DO NOT** set the parking brake.
4. Chock the front wheels of the vehicle.
5. Verify and maintain the air system at full operating pressure.
6. Verify the vehicle is at the correct ride height. Refer to vehicle manufacturer's instructions. Correct as necessary.
7. Verify all suspension components are in good condition. Repair or replace any worn or damaged suspension components before proceeding with the alignment process.
8. Ensure all drive axle tires are the same size and inflated to the correct tire pressure.
9. Use an alignment machine to calculate the drive axle readings.

NOTE

Depending on your alignment equipment, enter the vehicle year, make, model and design into the system's computer to determine the vehicle manufacturer's alignment specifications per the alignment equipment instructions. That data will be compared to the vehicle's actual alignment status to determine necessary corrections. Some systems allow you to simply scan the VIN to recall specs. Vehicle manufacturers have set specific alignment specifications.

10. If the measurements are within the vehicle manufacturer's specifications, then the rear drive axle alignment is acceptable. Proceed to check the pinion angles of the drive axles (Step 11).
 - a. If the alignment of the rear drive axle **IS NOT** within the vehicle manufacturer's specifications, then the alignment of this axle **MUST** be corrected **BEFORE** checking the drive axle pinion angles.
 - b. Correct the alignment of this axle by following the Alignment Adjustment instructions as shown in this section.
11. After all drive axles are aligned, check the pinion angle of each drive axle with a digital protractor, see Figure 7-1. Refer to the vehicle manufacturer specifications for the required pinion angles.
 - a. If all pinion angles are within the vehicle manufacturer's specifications then proceed to Step 12.
 - b. If any pinion angle is out of the vehicle manufacturer's specifications it must be corrected. Follow the Pinion Angle Adjustment procedure in this section.



12. Recheck measurements to confirm adjustments until the correct alignment and pinion angles are achieved.
13. When all drive axle alignments and pinion angles are within the vehicle manufacturer's specifications then the alignment procedure is complete.
14. Remove the wheel chocks.

AXLE PINION ANGLE

Drive axle pinion angles are established by the vehicle manufacturer. Bottom caps are machined to specific angles to meet the vehicle manufacturer's specified requirements. For the suspension bottom caps pinion angles, refer to the Parts List section of this publication.

To check the pinion angle:

1. Verify the suspension is at the proper ride height.
2. Place a digital protractor on the axle housing as shown in Figure 7-1.
3. Verify the pinion angle is within the range specified by the vehicle manufacturer.
4. Follow the Pinion Angle Adjustment in this section if necessary to fine-tune the pinion angle.

FIGURE 7-1



AXLE LATERAL ALIGNMENT

1. Use a work bay with a level surface.
2. Relax the suspension by slowly moving the vehicle back and forth several times in a straight line without using the brakes. This will slacken or loosen the suspension as the vehicle is positioned. End with all wheels positioned straight ahead. Try to roll to a stop without the brakes being used.
3. **DO NOT** set the parking brake.
4. Chock the front wheels of the vehicle.
5. Measure from the outside of the frame rail to the rim flange of the inner tire. Record the measurement **A** and **B**, see Figure 7-2.
6. Measure the same distance on the opposite side of the same axle. Record the measurement of **C** and **D**, see Figure 7-2.
7. Verify the axle lateral alignment is within the vehicle manufacturer's specifications. Adding or removing shims that are located between the transverse torque rod and the frame rail will normally correct the axle lateral alignment.
 - A general rule of thumb is to use a torque rod shim with a thickness that is half of the difference between the two measurements.

FIGURE 7-2

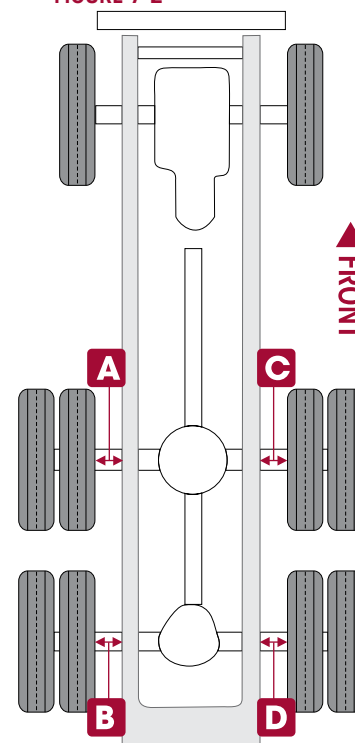

EXAMPLE

If the axle lateral alignment is out of specification by $\frac{1}{4}$ " (6 mm), remove or install a $\frac{1}{8}$ " (3 mm) torque rod shim between the transverse torque rod and frame rail as needed. Refer to Longitudinal and Transverse Torque Rod section in Preventive Maintenance section of this publication.

NOTE

Hendrickson recommends the use of Grade 8 bolts and Grade C locknuts. Washers are not necessary when flanged fasteners are used.



AXLE ALIGNMENT

ADJUSTMENT INSTRUCTIONS

SERVICE HINT

The eccentric collars (with the square drive feature) are located on the outboard side of the frame hangers with the concentric collars on the inboard side, see Figure 7-3. The total range of fore/aft axle adjustment is 1.0" ± ½".

FIGURE 7-3

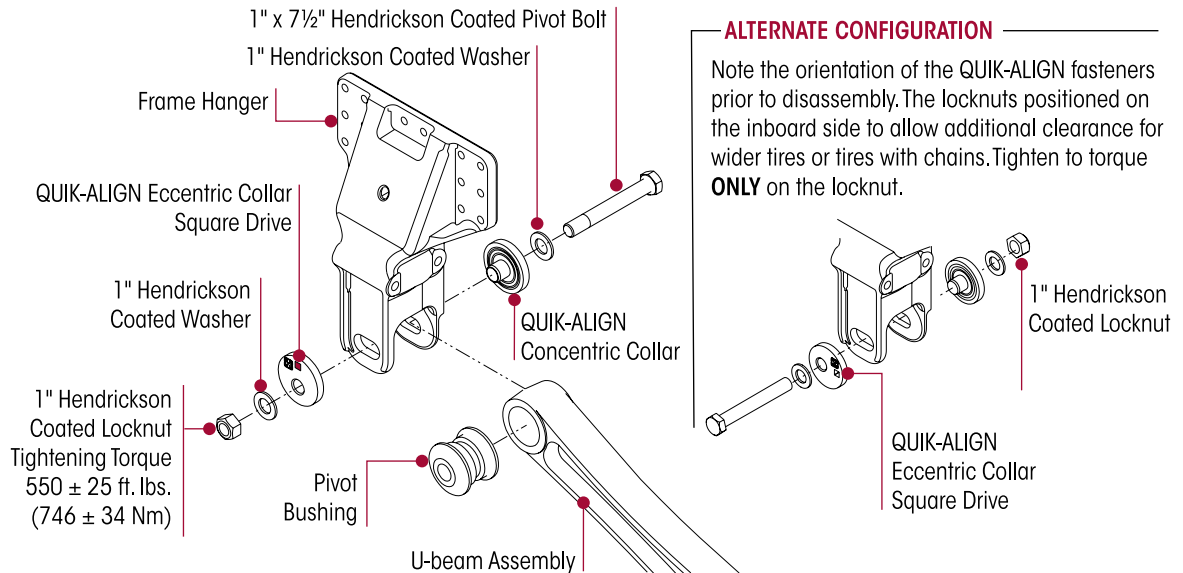

WARNING

DISCARD USED QUIK-ALIGN FASTENERS. ALWAYS USE NEW QUIK-ALIGN FASTENERS TO COMPLETE A REPAIR. FAILURE TO DO SO COULD RESULT IN FAILURE OF THE PART, OR MATING COMPONENTS, ADVERSE VEHICLE HANDLING, PERSONAL INJURY, OR PROPERTY DAMAGE.

WARNING

DO NOT ASSEMBLE QUIK-ALIGN JOINT WITHOUT THE PROPER FASTENERS. USE ONLY HENDRICKSON COATED GENUINE FASTENERS TO SUSTAIN PROPER CLAMP FORCE. ENSURE THAT THE QUIK-ALIGN FASTENER'S TORQUE VALUES ARE SUSTAINED AS RECOMMENDED IN THE TORQUE SPECIFICATIONS SECTION OF THIS PUBLICATION. FAILURE TO FOLLOW THE ABOVE ITEMS CAN CAUSE ADVERSE VEHICLE HANDLING RESULTING IN PERSONAL INJURY OR PROPERTY DAMAGE AND WILL VOID ANY APPLICABLE WARRANTIES. FOLLOW VEHICLE MANUFACTURER'S FASTENER ORIENTATION WHEN PERFORMING ANY MAINTENANCE, SERVICE, OR REPAIR.

1. Support the frame at ride height.

WARNING

PRIOR TO AND DURING DEFLATION AND INFLATION OF THE AIR SUSPENSION SYSTEM, ENSURE THAT ALL PERSONNEL AND EQUIPMENT ARE CLEAR FROM UNDER THE VEHICLE AND AROUND THE SERVICE AREA, FAILURE TO DO SO CAN CAUSE SERIOUS PERSONAL INJURY, DEATH, OR PROPERTY DAMAGE.

2. See additional Air Spring Warnings and Instructions in the Important Safety Notice section of this publication prior to deflating or inflating the suspension system.
3. Disconnect the linkage assembly from the height control valve arm. Lower the height control valve arm to exhaust the air in the air springs and deflate the rear suspension.

WARNING

SOME VEHICLE APPLICATIONS, SUCH AS VEHICLES EQUIPPED WITH OUTRIGGERS, RETAIN SOME AIR PRESSURE IN THE AIR SPRINGS AT ALL TIMES. PRIOR TO PERFORMING ANY MAINTENANCE, SERVICE, OR REPAIR OF THE SUSPENSION, VERIFY EACH AIR SPRING IS COMPLETELY DEFLATED. FAILURE TO DO SO COULD RESULT IN SERIOUS PROPERTY DAMAGE AND/OR SEVERE PERSONAL INJURY.

4. Using the measurements from the **Drive Axle Alignment Inspection** procedure, in this section, determine which QUIK-ALIGN collar requires an adjustment to correct the axle alignment.

**SERVICE HINT**

If the axle can be adjusted on both sides, begin the adjustment on the side that is furthest out of specification.

NOTE

Use a new QUIK-ALIGN pivot bolt kit (see the Parts List section of this publication) for any axle alignment or disassembly of the QUIK-ALIGN connection. This will help ensure that the proper clamp load is applied to the connection and help prevent the joint to slip in service.

5. On the side being adjusted, remove and discard QUIK-ALIGN fastener. Snug the new QUIK-ALIGN fastener to 50-100 foot pounds. This will hold the eccentric flanged collar in place against the frame hanger face, and within the adjustment guide, but loose enough to permit the QUIK-ALIGN eccentric flanged collar to rotate freely.
6. See additional Air Spring Warnings and Instructions in the Important Safety Notice section of this publication prior to deflating or inflating the suspension system.
7. Inflate the suspension per the vehicle manufacturer's instructions. Verify the air springs inflate uniformly without binding.
8. Verify correct ride height per the vehicle manufacturer's instructions.

NOTE

When adjusting the alignment of an axle, the fasteners connecting the longitudinal torque rod to the frame hanger, above the QUIK-ALIGN collar being adjusted, must be loose at the frame hanger. This will allow the longitudinal torque rod to move freely with the axle while the alignment is adjusted. Failure to do so will result in bushing preload in all rubber connections on that side of the axle, shortening component life.

9. On the side of the axle being adjusted, loosen the fasteners connecting the longitudinal torque rod to the frame hanger. Remove any existing shims from this connection. Leave the connection loose at this time.
10. Use a QUIK-ALIGN socket tool, see Figure 7-4 (refer to Special Tool section of this publication) and an impact gun, see Figure 7-5, or a ½" square drive breaker bar to rotate the QUIK-ALIGN eccentric collar to align the axle.

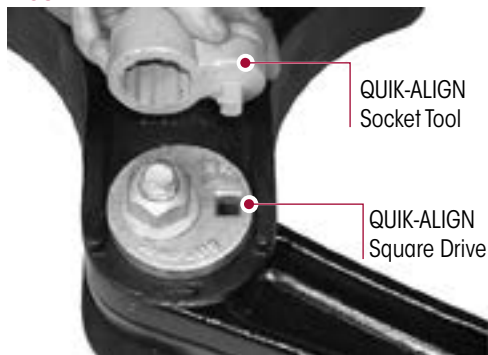
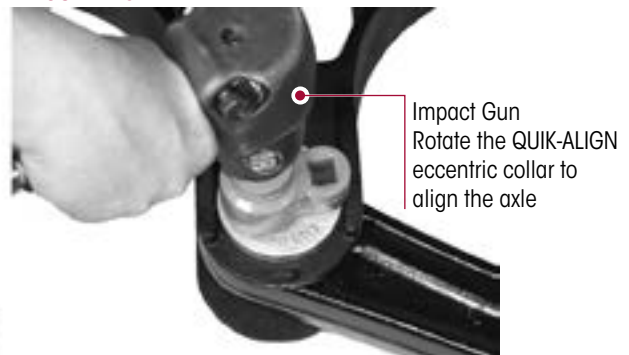
FIGURE 7-4**FIGURE 7-5**

- a. Once the correct axle alignment is achieved, use a calibrated torque wrench to tighten 1" QUIK-ALIGN locknut to 550 ± 25 foot pounds torque.
- b. Fill any gap between the frame hanger and longitudinal torque rod with shims.
- c. Tighten the longitudinal torque rod fasteners to the proper specification, see Torque Specifications section of this publication.
- d. Verify the ride height as per the vehicle manufacturer's specifications. Then proceed to the Drive Axle Alignment Inspection procedure in this section.



PINION ANGLE ADJUSTMENT

ADJUSTMENT OF 1.5 DEGREES OR LESS

NOTE

When correcting the pinion angle of an axle the correction must be in equal amounts on both sides of the axle. However, the total number of shims per side may differ due to axle alignment.

SERVICE HINT

A general rule of thumb is, $\frac{1}{8}$ " change in the shim pack thickness will increase or decrease the pinion angle by $\frac{1}{2}$ degree.

1. Loosen the fasteners connecting the longitudinal torque rods to the frame hangers.
2. Install or remove shims as required in **equal amounts**, to both sides of the axle to achieve the proper pinion angle, see Figure 7-6. To increase the pinion angle install shims, to decrease the pinion angle remove shims.
3. Tighten the longitudinal torque rod fasteners to proper torque specification, see Torque Specification section of this publication.
4. Re-check the pinion angle and verify it is within the vehicle manufacturer's specifications.

ADJUSTMENT OF MORE THAN 1.5 DEGREES

If an adjustment of **more** than 1.5 degrees is required, it will be necessary to replace both bottom caps on the axle with bottom caps that will achieve the desired pinion angle, refer to the Pinion Angle Chart in the Parts List section of this publication. After replacement of both bottom caps, perform the drive axle alignment procedure.

FIGURE 7-6





SECTION 8

Component Replacement

FASTENERS

When servicing a vehicle, Hendrickson recommends replacing all removed fasteners with new equivalent fasteners. Maintain correct torque values at all times. Check torque values as specified. See Hendrickson's Torque Specifications section of this publication. If non-Hendrickson fasteners are used follow torque specifications listed in the vehicle manufacturer's service manual.

HEIGHT CONTROL VALVE

Height control valve is not supplied by Hendrickson, although it is a required component. Hendrickson is not responsible for components supplied by the vehicle manufacturer. For assistance with inspection, adjustments, maintenance, replacement and rebuild instructions on these components, refer to vehicle manufacturer's instructions.

AIR SPRING

DISASSEMBLY

1. Chock the wheels.
2. Support the frame with safety stands.
3. Disconnect the height control valve arm(s) from the linkage assembly, see vehicle manufacturer's instructions.

WARNING

PRIOR TO AND DURING DEFLATION AND INFLATION OF THE AIR SUSPENSION SYSTEM, ENSURE THAT ALL PERSONNEL AND EQUIPMENT ARE CLEAR FROM UNDER THE VEHICLE AND AROUND THE SERVICE AREA, FAILURE TO DO SO CAN CAUSE SERIOUS PERSONAL INJURY, DEATH, OR PROPERTY DAMAGE.

WARNING

SOME VEHICLE APPLICATIONS, SUCH AS VEHICLES EQUIPPED WITH OUTRIGGERS, RETAIN SOME AIR PRESSURE IN THE AIR SPRINGS AT ALL TIMES. PRIOR TO PERFORMING ANY MAINTENANCE, SERVICE, OR REPAIR OF THE SUSPENSION, VERIFY EACH AIR SPRING IS COMPLETELY DEFLATED. FAILURE TO DO SO COULD RESULT IN SERIOUS PROPERTY DAMAGE AND/OR SEVERE PERSONAL INJURY.

4. See additional Air Spring Cautions and Warnings in the Important Safety Notice section of this publication prior to deflating or inflating the air system.
5. Lower the height control valve arm(s) to exhaust the air in the air springs and deflate the rear suspension.
6. Remove the air line from the air spring.

CAUTION

IF THE AIR SPRING IS BEING REMOVED FOR AN ALTERNATE REPAIR, IT IS MANDATORY TO LUBRICATE THE LOWER AIR SPRING FASTENERS WITH PENETRATING OIL AND REMOVE WITH HAND TOOLS TO PREVENT DAMAGE TO THE LOWER AIR SPRING MOUNTING STUD. FAILURE TO DO SO CAN CAUSE COMPONENT DAMAGE AND VOID WARRANTY.

7. If the air spring is being removed for an alternate repair it will be necessary to clean and lubricate the lower mounting fasteners with penetrating oil to prevent damage to the lower mounting stud.
8. Remove and discard the lower air spring mounting fasteners using **HAND TOOLS** only.
9. Remove the lower air spring mounting bracket from the cross tube.
10. Remove and discard the upper air spring mounting bracket fasteners from the frame per the vehicle manufacturer's instructions.
11. Remove the air spring.
12. Inspect the upper air spring bracket assembly, mounting surfaces, and the lower air spring mounting bracket for any damage. Replace as necessary.



ASSEMBLY



WARNING

FAILURE TO PRESS THE UPPER AIR SPRING BRACKET ASSEMBLY AGAINST THE UNDERSIDE OF THE FRAME WHILE TIGHTENING THE UPPER AIR SPRING FASTENERS CAN RESULT IN COMPONENT DAMAGE AND PERSONAL INJURY OR PROPERTY DAMAGE.

1. Press the upper air spring bracket assembly firmly against the underside of the frame and tighten frame fasteners to the proper torque per the original equipment manufacturer's specifications.
2. Attach the air spring to the upper air spring bracket assembly and tighten the locknuts to proper torque specifications, see Torque Specification section of this publication.
3. Install the air spring between the frame and cross tube, see Figure 8-1.
 - **PRIMAAX EX** — Ensure the **air spring slot** located in the bottom of the air spring engages the **beam notch** on the top of the U-beam assembly.
 - **PRIMAAX** — Ensure the **V notch** in the end cap engages the **locator tab** on the air spring.
4. Install the lower air spring mounting bracket around the cross tube, engaging the mounting air spring studs, see Figure 8-1.
5. Using **HAND TOOLS** only, install the lower mounting fasteners and tighten to 25 ± 5 foot pounds torque, see Figure 8-1.

FIGURE 8-1

PRIMAAX EX equipped with Integrated End Cap
Vehicles built after April 2011

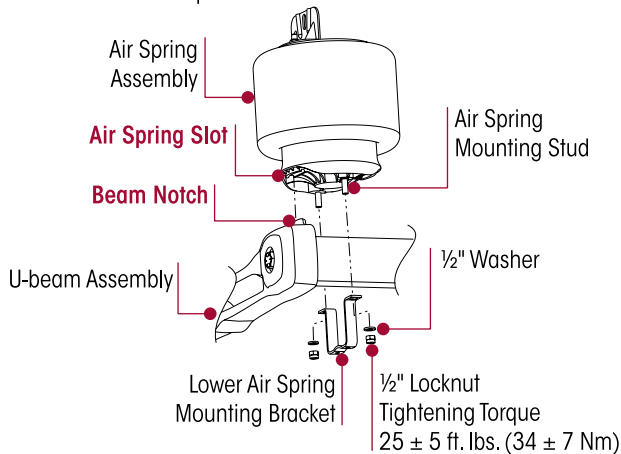

PRIMAAX equipped with Detachable End Cap
Out of production April 2011

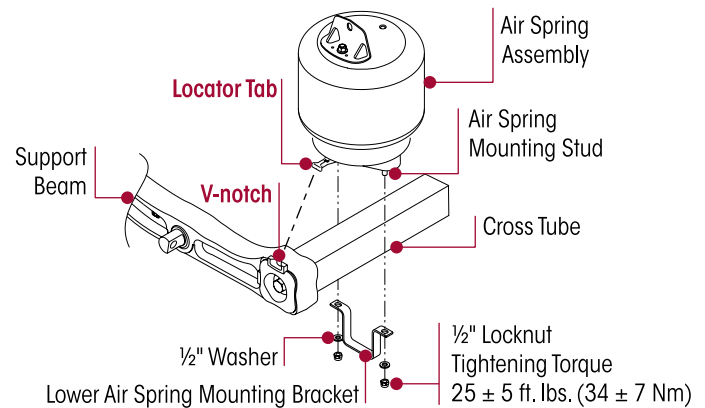

6. Install the air line fitting to the air spring using Teflon (or equivalent) thread seal.
7. Reconnect the air line to the air spring.
8. See additional Air Spring Cautions and Warnings in the Important Safety Notice section of this publication prior to deflating or inflating the air system.
9. Reconnect the linkage assembly to height control valve arm to inflate the suspension.
10. Inflate the suspension slowly and verify that the air spring bladder inflates uniformly without binding.
11. Remove the frame safety stands.
12. Verify the vehicle ride height as per the vehicle manufacturer's specifications.
13. Remove the wheel chocks.



SHOCK ABSORBER

NOTE It is not necessary to replace shock absorbers in pairs if only one (1) shock absorber requires replacement.

WARNING

THE SHOCK ABSORBERS ARE THE REBOUND TRAVEL STOPS FOR THE SUSPENSION. THE SHOCK ABSORBERS MUST REMAIN CONNECTED ANYTIME THE AXLE IS SUSPENDED OTHERWISE ALLOWED TO HANG ABOVE THE GROUND. FAILURE TO DO SO CAN CAUSE THE AIR SPRINGS TO SEPARATE FROM THE PISTON AND RESULT IN PREMATURE AIR SPRING FAILURE. REPLACEMENT OF SHOCK ABSORBERS WITH NON-HENDRICKSON PARTS CAN ALTER THE REBOUND TRAVEL OF THE SUSPENSION.

DISASSEMBLY

1. Chock the wheels of the vehicle.

NOTE If may be necessary to remove the height control valve linkage bracket for shock absorber replacement, if so, mark the position of the linkage bracket to facilitate reinstallation.

2. Remove and discard the **lower** shock absorber mounting fasteners and, if necessary, the height control valve linkage bracket, see Figure 8-2.
3. Remove and discard the **upper** shock absorber mounting fasteners.
4. Slide the shock absorber out of the **upper** mounting bracket.
5. Inspect the shock absorber mounting brackets and hardware for damage or wear, replace as necessary. Refer to Preventive Maintenance section of this publication.

FIGURE 8-2

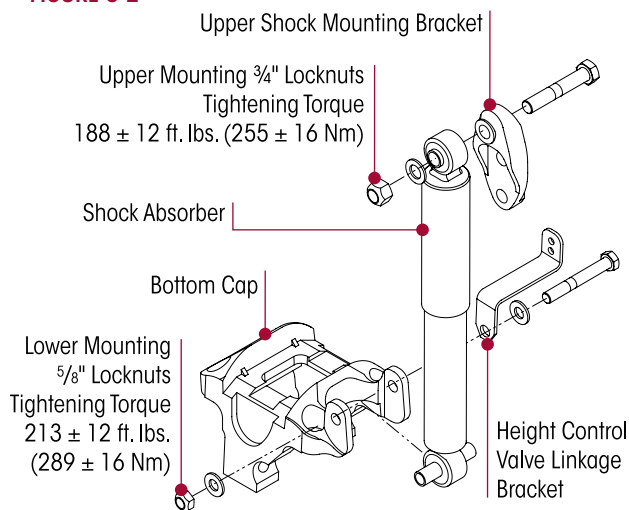

ASSEMBLY

1. Install the upper shock absorber mounting bracket (if removed).
2. Install the shock absorber into the upper mounting bracket.
3. Install the upper shock absorber mounting fasteners.

CAUTION

THE UPPER SHOCK BOLT MUST BE INDEXED INTO THE RECESSED HEX BORE OF THE UPPER SHOCK FRAME BRACKET FOR PROPER FASTENER INSTALLATION. FAILURE TO DO SO CAN CAUSE THE SHOCK FASTENERS TO BECOME LOOSE AND CAUSE PREMATURE COMPONENT DAMAGE.

4. Slide the lower shock absorber mount into the bottom cap.
5. Install the lower shock absorber mounting fasteners and height control valve linkage bracket (if removed).
6. Tighten the upper shock absorber mounting $\frac{3}{4}$ " locknuts to 188 ± 12 foot pounds torque, see Figure 8-2.
7. Tighten the lower shock absorber mounting $\frac{5}{8}$ " locknuts to 213 ± 12 foot pounds torque, see Figure 8-2.
8. Install the linkage bracket per the marked position if removed.
9. Verify the vehicle ride height as per the vehicle manufacturer's specifications.
10. Remove the wheel chocks.



LONGITUDINAL TORQUE ROD

NOTE Longitudinal torque rods assemblies equipped on the PRIMAAX EX • PRIMAAX suspension for Volvo vehicles have curled end hubs and are non-bushable. The entire torque rod assembly must be replaced. This feature provides superior bushing retention in the torque rod end hub.

DISASSEMBLY

1. Chock the wheels of the vehicle.

SERVICE HINT

Note the quantity of shims removed to maintain the correct pinion angle of the axle at assembly. See Alignment & Adjustments section of this publication.

2. Remove and discard the longitudinal torque rod fasteners and shims (if equipped) that connect to the frame hanger, see Figure 8-3.
3. Remove and discard the longitudinal torque rod fasteners that connect to the top pad, see Figure 8-3.
4. Remove the longitudinal torque rod.
5. Inspect the mounting surfaces for any wear or damage, replace if necessary.

FIGURE 8-3

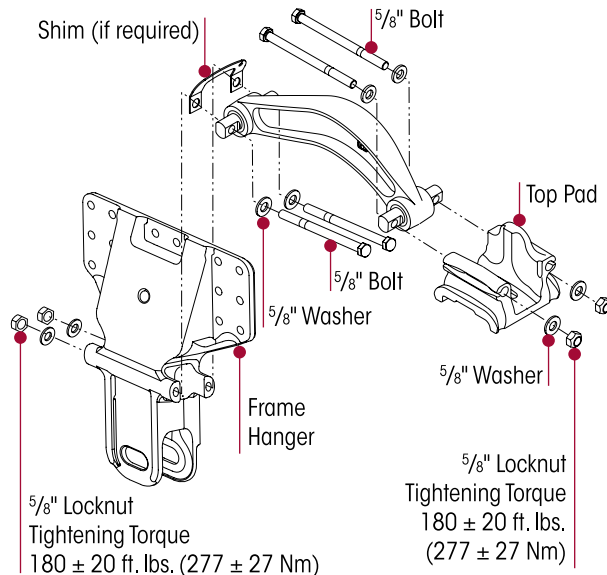

Alternate configuration for vehicles built prior to March 2018

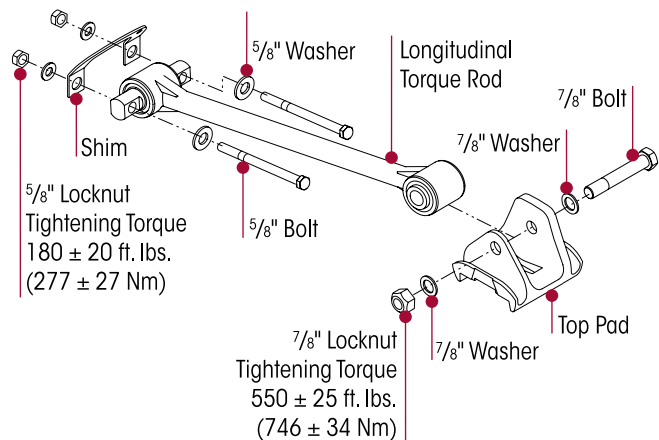

ASSEMBLY

1. Install the longitudinal torque rod.
2. Install the new mounting fasteners and any shims that were removed, see Figure 8-3.

NOTE Hendrickson recommends the use of Grade 8 bolts and Grade C locknuts be used for all torque rod attachments.

NOTE It is mandatory to have the vehicle at proper ride height prior to tightening the longitudinal torque rod locknuts to torque specifications.

3. Tighten:
 - 5/8"locknuts to 180 ± 20 foot pounds torque, see Figure 8-3
 - 7/8"locknuts to 550 ± 25 foot pounds torque, see Figure 8-3.
4. When the assembly is complete check the drive axle pinion angles, see Alignment & Adjustments section of this publication.
5. Remove the wheel chocks.



TRANSVERSE TORQUE ROD



WARNING

THIS HENDRICKSON SUSPENSION REQUIRES TORQUE RODS FOR SUSPENSION PERFORMANCE AND VEHICLE STABILITY. IF THESE TORQUE RODS ARE DISCONNECTED OR ARE NON-FUNCTIONAL, DO NOT OPERATE THE VEHICLE. OPERATING A VEHICLE WITH DISCONNECTED OR NON-FUNCTIONAL TORQUE RODS CAN RESULT IN ADVERSE VEHICLE HANDLING, COMPONENT DAMAGE, SUSPENSION/VEHICLE DAMAGE, AND/OR SEVERE PERSONAL INJURY.

NOTE

Transverse torque rods are not supplied by Hendrickson, although it is a required component. Hendrickson is not responsible for components supplied by the vehicle manufacturer. For assistance with inspection, maintenance and rebuild instructions on these components, refer to vehicle manufacturer's instructions.

DISCONTINUED – SUPPORT BEAM ASSEMBLY AND CROSS TUBE

NOTE

Effective May 2010, the support beam assembly part numbers 66435-00X or 60831-00X (Forging part numbers 59363-001, 65082-000, 65284-000), cross tube, and previous U-beam assembly part numbers with the prefix 66659-XXX, for PRIMAAX suspension systems were discontinued, see Figure 8-5.

The U-beam assembly with integrated end caps, see Figure 8-4, is now a required replacement for any PRIMAAX support beam or cross tube component. Refer to the Support Beam and Cross Tube Replacement Guide table in the Parts List section of this publication.

FIGURE 8-4

REPLACEMENT U-BEAM ASSEMBLY KIT

Replacement

- U-beam Assembly
Service Kit No.
60961-XXX

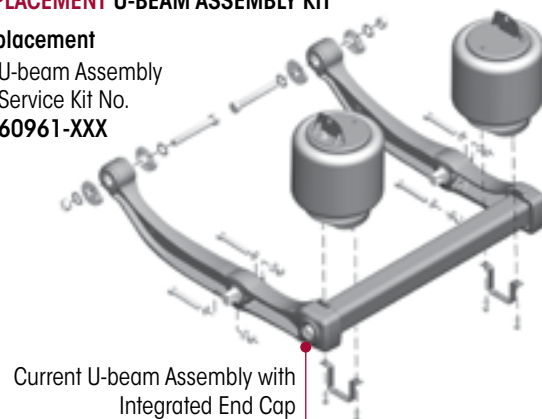
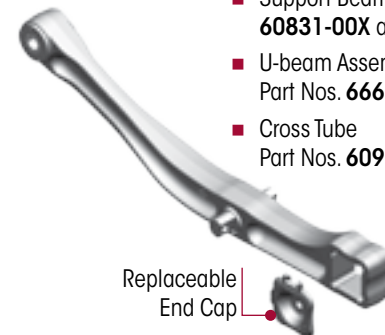

FIGURE 8-5

FORMER SUPPORT BEAM ASSEMBLY

Discontinued May 2010

- Support Beam Part Nos.
60831-00X and **66435-00X**
- U-beam Assembly
Part Nos. **66659-XXX**
- Cross Tube
Part Nos. **60912-XXX**



U-BEAM ASSEMBLY

IMPORTANT NOTICE

As of September 2010, Hendrickson introduced the new enhanced U-beam assembly design for PRIMAAX EX suspensions equipped on new production vehicles and for the aftermarket. The new U-beam assembly results in a maintenance-free integrated end cap connection. See Hendrickson publication SEU-0229 for PRIMAAX support beam/cross tube assembly conversion to the new U-beam assembly enhancement or refer to the Parts List section of this publication.

DISASSEMBLY

1. Chock the front wheels.
2. Support the frame at ride height with safety stands.
3. Raise and support the axle with safety stands.
4. Remove the wheel assembly per the vehicle manufacturer's instructions.
5. Disconnect the linkage assemblies from the height control valve arms.



WARNING

PRIOR TO AND DURING DEFLATION AND INFLATION OF THE AIR SUSPENSION SYSTEM, ENSURE THAT ALL PERSONNEL AND EQUIPMENT ARE CLEAR FROM UNDER THE VEHICLE AND AROUND THE SERVICE AREA, FAILURE TO DO SO CAN CAUSE SERIOUS PERSONAL INJURY, DEATH, OR PROPERTY DAMAGE.

WARNING

SOME VEHICLE APPLICATIONS, SUCH AS VEHICLES EQUIPPED WITH OUTRIGGERS, RETAIN SOME AIR PRESSURE IN THE AIR SPRINGS AT ALL TIMES. PRIOR TO PERFORMING ANY MAINTENANCE, SERVICE, OR REPAIR OF THE SUSPENSION, VERIFY EACH AIR SPRING IS COMPLETELY DEFLATED. FAILURE TO DO SO COULD RESULT IN SERIOUS PROPERTY DAMAGE AND/OR SEVERE PERSONAL INJURY.

6. See additional Air Spring Cautions and Warnings in the Important Safety Notice section of this publication prior to deflating or inflating the air system.
7. Lower the height control valve arm(s) to exhaust the air in the air springs and deflate the rear suspension.
8. Remove the air line from the air spring.

CAUTION

IF THE AIR SPRING IS BEING REMOVED FOR AN ALTERNATE REPAIR, IT IS MANDATORY TO LUBRICATE THE LOWER AIR SPRING FASTENERS WITH PENETRATING OIL AND REMOVE WITH HAND TOOLS TO PREVENT DAMAGE TO THE LOWER AIR SPRING MOUNTING STUD. FAILURE TO DO SO CAN CAUSE COMPONENT DAMAGE AND VOID WARRANTY.

9. Lubricate the lower mounting fasteners of the air springs with penetrating oil. This will help prevent the air spring mounting studs from breaking during the removal process.
10. Remove and discard the lower mounting fasteners from the air springs using **HAND TOOLS** only.
11. Remove both the lower air spring mounting brackets to disconnect both air springs from the cross tube, refer to Air Spring in this section.

WARNING

USE ONLY A FLOOR JACK EQUIPPED WITH A FOUR INCH CONTACT PLATE TO SUPPORT THE U-BEAM ASSEMBLY AT THE CROSS TUBE TO FACILITATE SAFE LOWERING AND RAISING OF THE U-BEAM ASSEMBLY. DO NOT USE A BOTTLE JACK, WHICH DOES NOT HAVE ENOUGH CONTACT AREA AND CAN BE UNSTABLE. FAILURE TO DO SO CAN CAUSE COMPONENT DAMAGE OR RESULT IN PERSONAL INJURY.

12. Install a floor jack with a 4" contact plate to support the U-beam assembly at the cross tube.

SERVICE HINT

Each frame hanger will have a pair of QUIK-ALIGN collars. Note which type of QUIK-ALIGN collar is removed from which frame hanger location to facilitate the assemble process. Any eccentric (with the square drive feature, see Figure 8-6) QUIK-ALIGN collar should be mounted on the outboard side of the frame hanger. Axle thrust angles can only be corrected on frame hangers equipped with eccentric QUIK-ALIGN collars.

13. Mark the position of the QUIK-ALIGN **square drive** in relationship to the frame hanger and note the **orientation of the fasteners** prior to loosening the QUIK-ALIGN connection. This will facilitate the axle alignment process after the repair is complete, see Figure 8-6.
14. Loosen both QUIK-ALIGN fasteners, **DO NOT** remove at this time.
15. Remove and discard D-pin fasteners on both sides of the suspension.

SERVICE HINT

It may be necessary to rotate the QUIK-ALIGN eccentric collars to allow the full disengagement of the D-pins into the bottom caps.

SERVICE HINT

It may be necessary to raise the front of the differential to allow the D-pins to disengage the bottom caps.

WARNING

THE WEIGHT OF THE U-BEAM ASSEMBLY IS APPROXIMATELY 225 POUNDS. CARE SHOULD BE TAKEN AT REMOVAL AND INSTALLATION TO PREVENT PERSONAL INJURY OR DAMAGE TO COMPONENTS.

16. Lower the floor jack and pivot the U-beam assembly down.
17. Remove and discard the QUIK-ALIGN fasteners.



FIGURE 8-6

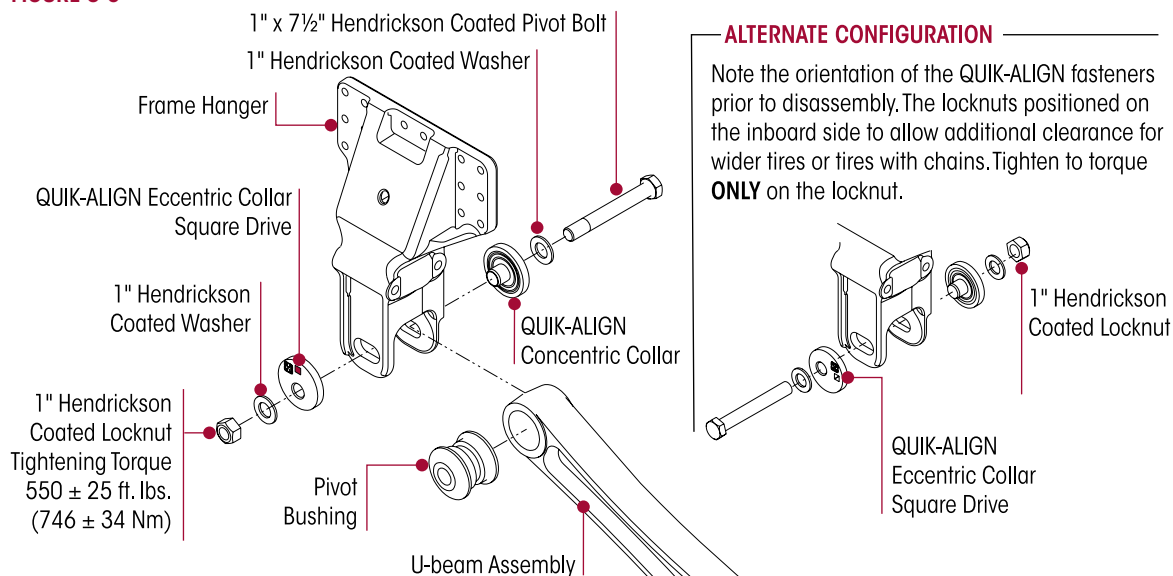

18. Remove QUIK-ALIGN eccentric and concentric collars.

NOTE

It may be necessary to use a pry bar to push the U-beam assembly out of the frame hangers.

19. Remove the U-beam assembly from the frame hangers.

20. Remove the U-beam assembly from the vehicle.

ASSEMBLY

1. Clean the QUIK-ALIGN slots in the hangers and collars of any dirt and debris and inspect for any wear or damage. Replace as necessary.
2. Prior to installing the U-beam assembly, verify the clamp group is tightened to the proper torque.

WARNING

THE WEIGHT OF THE U-BEAM ASSEMBLY IS APPROXIMATELY 225 POUNDS. CARE SHOULD BE TAKEN AT REMOVAL AND INSTALLATION TO PREVENT PERSONAL INJURY OR DAMAGE TO COMPONENTS.

3. Install the U-beam assembly into the frame hangers.

WARNING

DISCARD USED QUIK-ALIGN FASTENERS. ALWAYS USE NEW QUIK-ALIGN FASTENERS TO COMPLETE A REPAIR. FAILURE TO DO SO COULD RESULT IN FAILURE OF THE PART, OR MATING COMPONENTS, ADVERSE VEHICLE HANDLING, POSSIBLE PERSONAL INJURY, OR PROPERTY DAMAGE.

WARNING

DO NOT ASSEMBLE QUIK-ALIGN JOINT WITHOUT THE PROPER FASTENERS. USE ONLY HENDRICKSON COATED GENUINE FASTENERS TO SUSTAIN PROPER CLAMP FORCE. ENSURE THAT THE QUIK-ALIGN FASTENER'S TORQUE VALUES ARE SUSTAINED AS RECOMMENDED IN THE TORQUE SPECIFICATIONS SECTION OF THIS PUBLICATION. FAILURE TO FOLLOW THE ABOVE ITEMS CAN CAUSE ADVERSE VEHICLE HANDLING RESULTING IN PERSONAL INJURY OR PROPERTY DAMAGE AND WILL VOID ANY APPLICABLE WARRANTIES. FOLLOW VEHICLE MANUFACTURER'S FASTENER ORIENTATION WHEN PERFORMING ANY MAINTENANCE, SERVICE, OR REPAIR.

NOTE

Use a new QUIK-ALIGN pivot bolt kit (see the Parts List section of this publication) for any axle alignment or disassembly of the QUIK-ALIGN connection. This will help ensure that the proper clamp load is applied to the connection and help prevent the joint to slip in service.

4. Verify the location of the QUIK-ALIGN collars (eccentric/concentric) as previously noted in the disassembly procedure.
5. Install the QUIK-ALIGN fasteners and snug to about 50-100 foot pounds torque, DO NOT tighten at this time. The final torque must be done after the alignment is complete.
6. Position the U-beam assembly on a floor jack.



7. Raise the U-beam assembly until the D-pins engage into the bottom cap.

SERVICE HINT

It may be necessary to rotate the QUIK-ALIGN eccentric collars to allow the full engagement of the D-pins into the bottom caps.

SERVICE HINT

It may be necessary to raise or lower the front of the differential to allow the D-pins to engage in the bottom cap. Use a drift pin if necessary to align the D-pins with the bottom cap.

8. Install the D-pin fasteners from front to back, see Figure 8-8.
9. Remove the floor jack supporting the U-beam assembly.
10. Tighten the D-pin fasteners to \mathbb{N} 300 ± 25 foot pounds torque, see Figure 8-7.

FIGURE 8-7
Clamp Group &
D-pin Fasteners

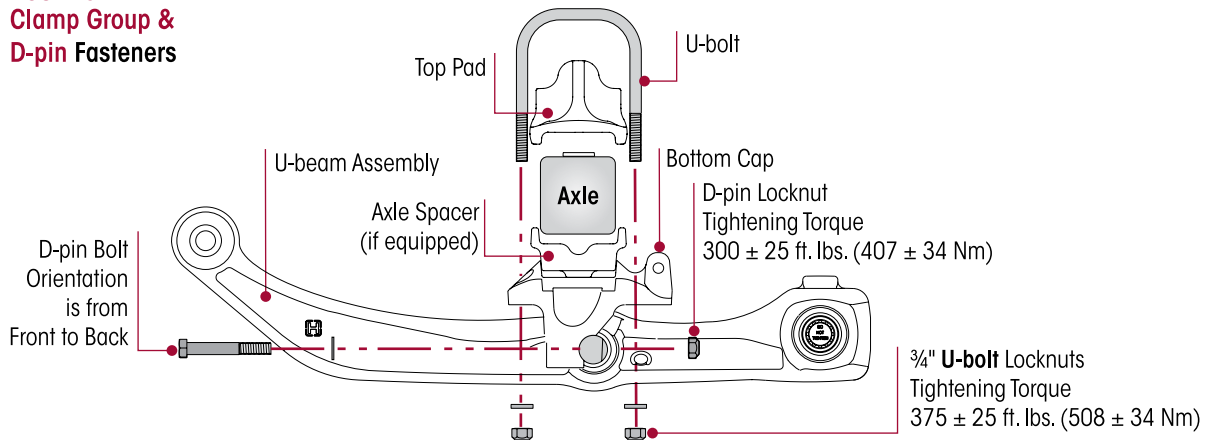

11. Install the air springs between the frame and cross tube, refer to the Air Spring instructions in this section.
12. Install the wheel assemblies per the vehicle manufacturer's instructions.
13. Remove the axle safety stands.
14. See additional Air Spring Cautions and Warnings in the Important Safety Notice section of this publication prior to deflating or inflating the air system.
15. Connect the linkage assemblies to the height control valve arms to inflate the suspension.
16. Remove the frame safety stands.
17. Remove the wheel chocks.

NOTE

Alignment and QUIK-ALIGN final torque is necessary anytime the U-beam assembly is removed.



18. Check the alignment and adjust if necessary. See Alignment & Adjustments section of this publication.
19. Once the correct axle alignment is achieved, use a calibrated torque wrench to tighten the 1" QUIK-ALIGN locknut to \mathbb{N} 550 ± 25 foot pounds torque.



D-PIN BUSHING

You will need:

- Hendrickson Tool Part Nos. 66086-204 • 66086-202 (OTC Nos. 4247 • 4246), refer to the Special Tools section of this publication

REMOVAL		✓	✓	✓
INSTALLATION	✓		✓	✓
D-PIN BUSHING	 575164 Saddle	 575163 Adapter Pin	 576421 D-pin Adapter	 575167 Alignment Tool

DISASSEMBLY

1. Mark the support beam of the U-beam assembly to show the alignment of the existing D-pin. Install the alignment tool over the D-pin, and place the clamping plate over the alignment tool, see Figure 8-8.
2. Assemble the clamping nuts to the threaded rods.
3. Insert a threaded rod through the **upper** holes in the clamping plate and the head plate. Install a hex nut on the threaded rod, but **DO NOT** tighten at this time.
4. Insert a threaded rod through the **lower** holes in the clamping plate and the head plate. Install a hex nut on the threaded rod, but **DO NOT** tighten at this time.
5. Tighten the clamping nuts to the clamping plate, see Figure 8-9.
6. Ensure the clamping plate and head plate are parallel to each other.

FIGURE 8-8

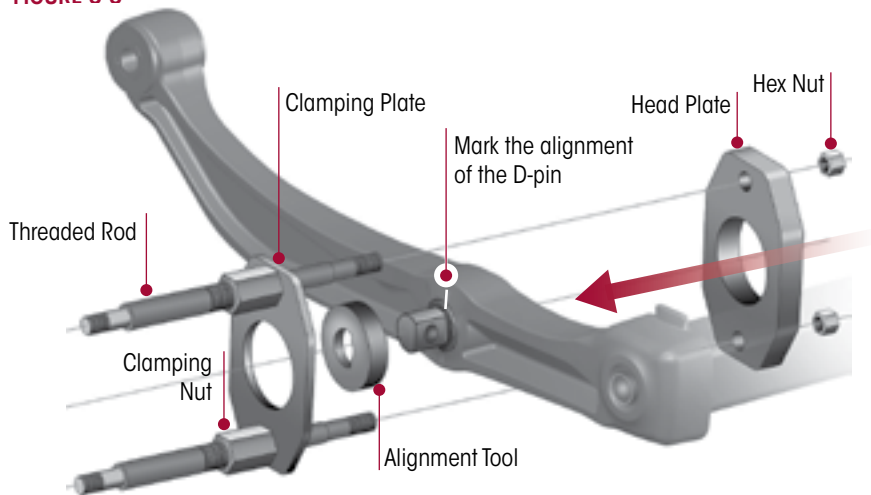
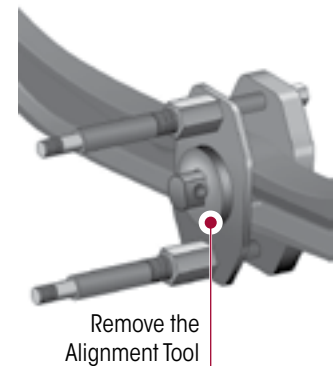

FIGURE 8-9

TOOL ASSEMBLY
After Steps 1-5



7. Remove the alignment tool.



WARNING

TO HELP PREVENT PERSONAL INJURY, THE CYLINDER MUST BE FULLY THREADED INTO THE CYLINDER MOUNTING PLATE.

8. Thread the cylinder into the cylinder mounting plate, see Figure 8-10.
9. Install the cylinder mounting plate onto the end of the threaded rods. Adjust the clamping nuts as needed to fit the threaded rods through the holes in the cylinder mounting plate. Assemble the hex nuts on the threaded rods. Tighten the hex nuts on both ends of the threaded rods.
10. Place the D-pin adapter over the D-pin.
11. Insert the adapter pin into the head of the cylinder.



WARNING

TO HELP PREVENT PERSONAL INJURY, THE HYDRAULIC PUMP RATING MUST NOT EXCEED 10,000 PSI.



FIGURE 8-10

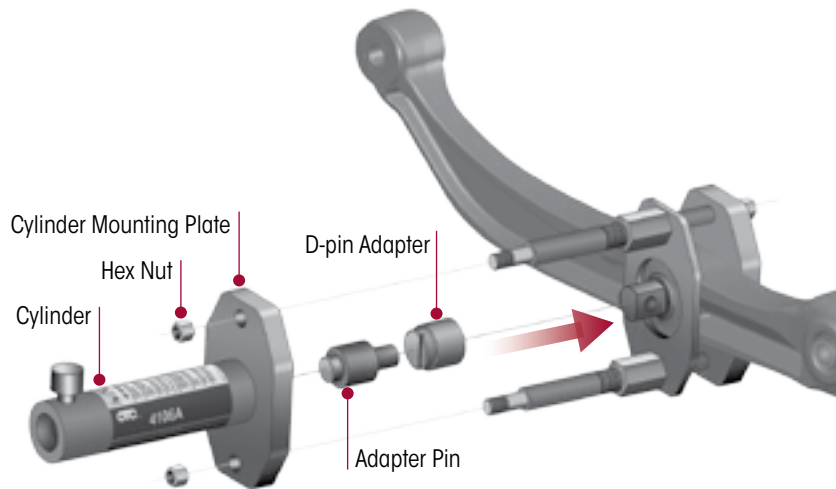

12. Prepare the hydraulic pump for use by following the manufacturer's instructions provided with the pump regarding hookup, venting, priming, and operation.



WARNING

TO HELP PREVENT PERSONAL INJURY STAY CLEAR OF THE HYDRAULIC PUMP, ADJACENT TOOLS, AND THE DIRECTION OF THE HYDRAULIC FORCE WHILE THE D-PIN IS BEING EXTRACTED.

13. Connect the hydraulic hose from the hydraulic pump to the cylinder.

14. Operate the pump to extend the cylinder piston and apply pressure to push the D-pin out of the support beam of the U-beam assembly.

ASSEMBLY

1. Clean and thoroughly lubricate the entire surface of the inside diameter of the support beam, see Figure 8-11.

2. Insert the saddle into the head of the cylinder.

3. Assemble the new D-pin and the D-pin adapter as shown. Align the line in the D-pin adapter with the alignment marks made during the removal procedure.

4. Operate the pump to extend the cylinder piston and apply enough pressure to hold the tool and components. Check the alignment of the D-pin. The centerline of the D-pin must be aligned with the centerline of the inside diameter of the support beam.



WARNING

TO HELP PREVENT PERSONAL INJURY STAY CLEAR OF THE HYDRAULIC PUMP, ADJACENT TOOLS, AND THE DIRECTION OF THE HYDRAULIC FORCE WHILE THE D-PIN IS BEING EXTRACTED.

5. Operate the pump to apply pressure to install the D-pin completely into the support beam.

FIGURE 8-11

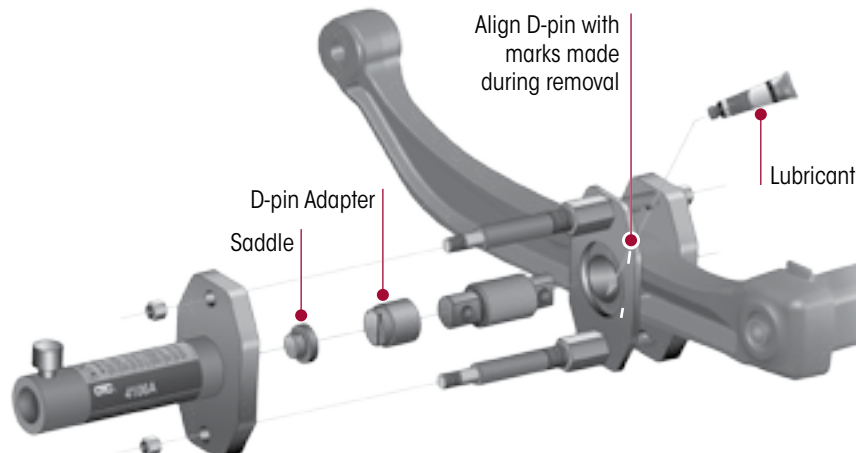







QUIK-ALIGN PIVOT BUSHING

You will need:

- **Method A:** Hendrickson Tool Part Nos. 66086-202 • 66086-204 (OTC Nos. 4246 • 4247) and **Method B:** 66086-203L, refer to the Special Tools section in this publication

METHOD A – USING TOOL NOS. 66086-202 • 66086-204

REMOVAL	✓	✓	✓	✓
INSTALLATION	✓		✓	✓
QUIK-ALIGN BUSHING	575163 Adapter Pin 	576421 D-pin Adapter 	575165 Bushing Support 	575167 Alignment Tool 

DISASSEMBLY

1. Insert the adapter pin through the alignment tool and into the pivot bushing hole as shown in Figure 8-12.
2. Insert the bushing support over the pivot bushing.
3. Assemble the clamping nuts to the threaded rods.
4. Insert a threaded rod through the upper holes in the clamping plate and the head plate while positioning the head plate over the bushing support. Install a hex nut on the threaded rod, but **DO NOT** tighten at this time.
5. Insert a threaded rod through the lower holes in the clamping plate and the head plate. Install a hex nut on the threaded rod, but **DO NOT** tighten at this time.
6. Tighten the clamping nuts to the clamping plate, see Figure 8-13.

FIGURE 8-12

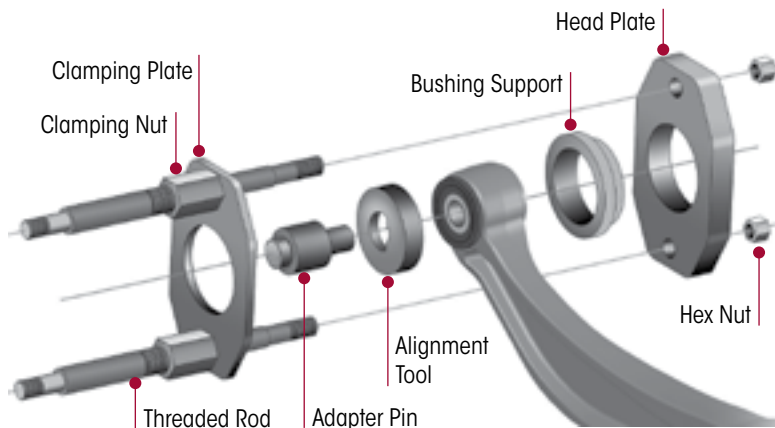
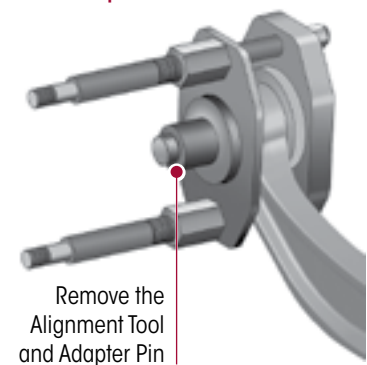

FIGURE 8-13
Tool assembly after Steps 1-6



7. Remove the alignment tool and adapter pin.



WARNING

TO HELP PREVENT PERSONAL INJURY, THE CYLINDER MUST BE FULLY THREADED INTO THE CYLINDER MOUNTING PLATE.

8. Thread the cylinder into the cylinder mounting plate, see Figure 8-14.
9. Install the cylinder mounting plate onto the end of the threaded rods. Adjust the clamping nuts as needed to fit the threaded rods through the holes in the cylinder mounting plate. Assemble the hex nuts on the threaded rods. Tighten the hex nuts on both ends of the threaded rods.



FIGURE 8-14

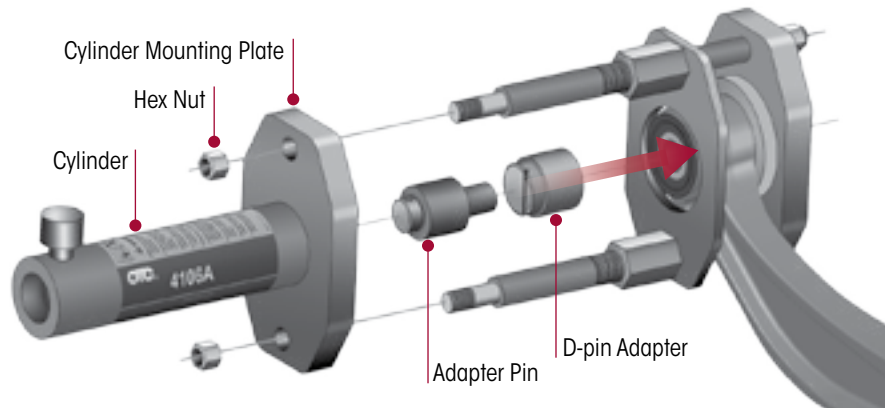

10. Hold the D-pin adapter over the pivot bushing until contact is made with the adapter pin.

11. Insert the adapter pin into the head of the cylinder.



WARNING

TO HELP PREVENT PERSONAL INJURY, THE HYDRAULIC PUMP RATING MUST NOT EXCEED 10,000 PSI.

12. Prepare the hydraulic pump for use by following the instructions provided with the pump regarding hookup, venting, priming, and operation.



WARNING

TO HELP PREVENT PERSONAL INJURY STAY CLEAR OF THE HYDRAULIC PUMP, ADJACENT TOOLS, AND THE DIRECTION OF THE HYDRAULIC FORCE WHILE THE D-PIN IS BEING EXTRACTED.

13. Connect the hydraulic hose from the hydraulic pump to the cylinder.

14. Operate the pump to extend the cylinder piston and apply pressure to push the pivot bushing out of the support beam.

ASSEMBLY

1. Clean and thoroughly lubricate the entire surface of the inside diameter of the support beam, see Figure 8-15.

2. Insert the adapter pin into the head of the cylinder.

3. Place the pivot bushing on the end of the adapter pin as shown.

4. Operate the pump to extend the cylinder piston and apply enough pressure to hold the tool and components. Check the alignment of the pivot bushing.



WARNING

TO HELP PREVENT PERSONAL INJURY STAY CLEAR OF THE HYDRAULIC PUMP, ADJACENT TOOLS, AND THE DIRECTION OF THE HYDRAULIC FORCE WHILE THE PIVOT BUSHING IS BEING EXTRACTED.

FIGURE 8-15

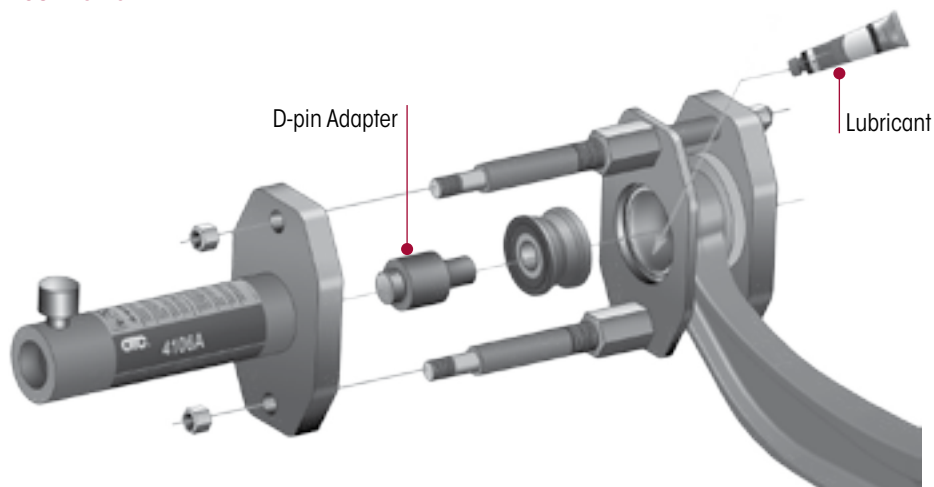



- Operate the pump to apply pressure to install the pivot bushing completely into the support beam of the U-beam assembly.

METHOD B – Using Tool No. 66086-203L

SERVICE HINT

Use the QUIK-ALIGN Pivot Bushing Tool No. 66086-203L to help with the installation and removal of QUIK-ALIGN pivot bushings. The tool allows the existing pivot bushing to be pushed out from the U-beam assembly into the receiving cylinder. Then follow a similar procedure to push in the replacement pivot bushing, see Figure 8-16.

FIGURE 8-16

NOTE
 Apply NLGI #2-EP chassis lubricant to each face of the thrust washers and to the drive screw that will engage through the receiving cylinder.
 Apply P80 lubricant to the face of the lead-in flange and the outer diameter of NEW pivot bushing

**QUIK-ALIGN Pivot Bushing Tool
 Part No. 66086-203L**

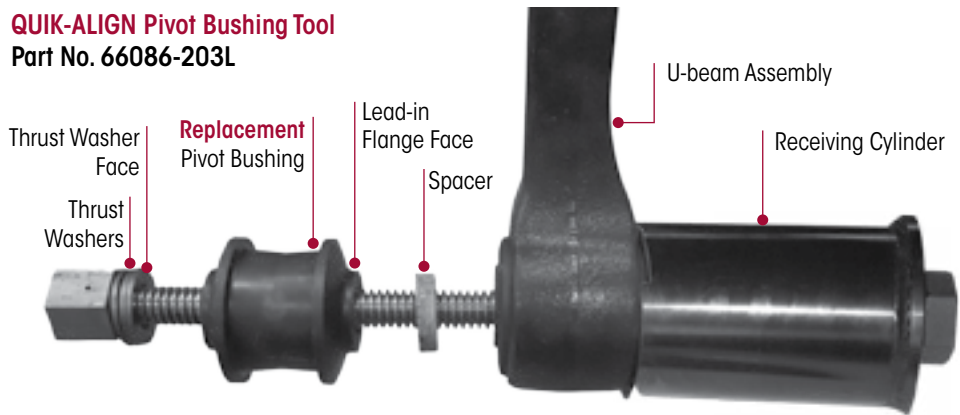

WARNING

A TECHNICIAN USING A SERVICE PROCEDURE OR TOOL WHICH HAS NOT BEEN RECOMMENDED BY HENDRICKSON MUST FIRST SATISFY HIMSELF THAT NEITHER HIS SAFETY NOR THE VEHICLE'S SAFETY WILL BE JEOPARDIZED BY THE METHOD OR TOOL SELECTED. INDIVIDUALS DEVIATING IN ANY MANNER FROM THE INSTRUCTIONS PROVIDED WILL ASSUME ALL RISKS OF CONSEQUENTIAL PERSONAL INJURY OR DAMAGE TO EQUIPMENT INVOLVED.

- Remove the U-beam assembly from the vehicle per the U-beam Disassembly procedure in this section.
- After removal, place U-beam assembly on the floor or suitable work area.

PIVOT BUSHING REMOVAL

NOTE

When replacing a pivot bushing it is recommended to replace both pivot bushings on the U-beam assembly.

To replace the QUIK-ALIGN pivot bushing you will need:

- QUIK-ALIGN pivot bushing service tool (Part No. 66086-203L), see Figure 8-16
 - ¾" Impact wrench (impact gun), some ½" impact wrenches may work
- Install the pivot bushing tool as shown in Figure 8-17.
 - Remove and discard thrust washers (if equipped) and any loose rubber or debris from the existing pivot bushing.

FIGURE 8-17

Apply NLGI #2-EP chassis lubricant to each face of the thrust washers, and drive screw that will engage through the receiving cylinder.

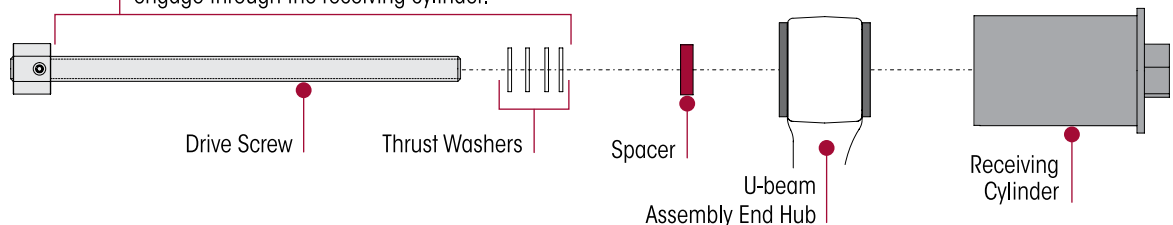



3. Apply NLGI #2-EP (Extreme Pressure) chassis lubricant to each face of the thrust washers and to the drive screw that will engage through the receiving cylinder, see Figure 8-17.
4. Snug the threaded drive screw to hold the thrust washers, spacer, U-beam assembly with the existing pivot bushing and the receiving cylinder in place, see Figure 8-18.
5. Using a 3/4" impact wrench, rotate the drive screw in a continuous motion without stopping until the pivot bushing is removed from the end hub. The existing pivot bushing will enter into the receiving cylinder, see Figure 8-19.
6. Remove and discard pivot bushing.
7. Repeat Steps 1 through 6 for the other side of the U-beam assembly, as recommended.

FIGURE 8-18

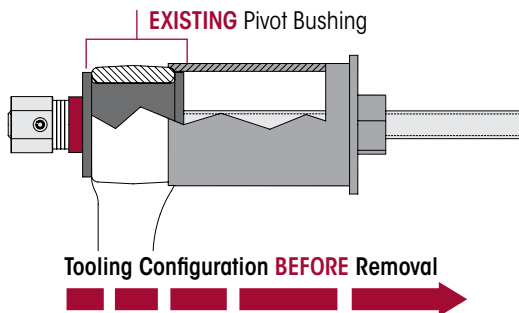
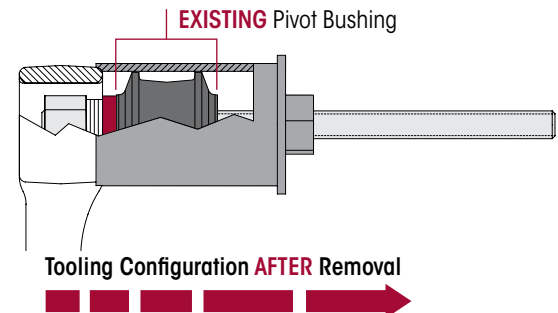

FIGURE 8-19



END HUB INSPECTION

Inspect the inner bore of the U-beam assembly end hub and remove any loose debris or rubber residue from the bushing mating surface.

PIVOT BUSHING INSTALLATION

1. Clean the inner diameter of the U-beam assembly end hub with brake cleaner.
2. Apply NLGI #2-EP (Extreme Pressure) chassis lubricant to each face of the thrust washers and to the drive screw that will engage through the receiving cylinder, see Figures 8-20 and 8-21.

FIGURE 8-20
Heavy-duty Pivot Bushing

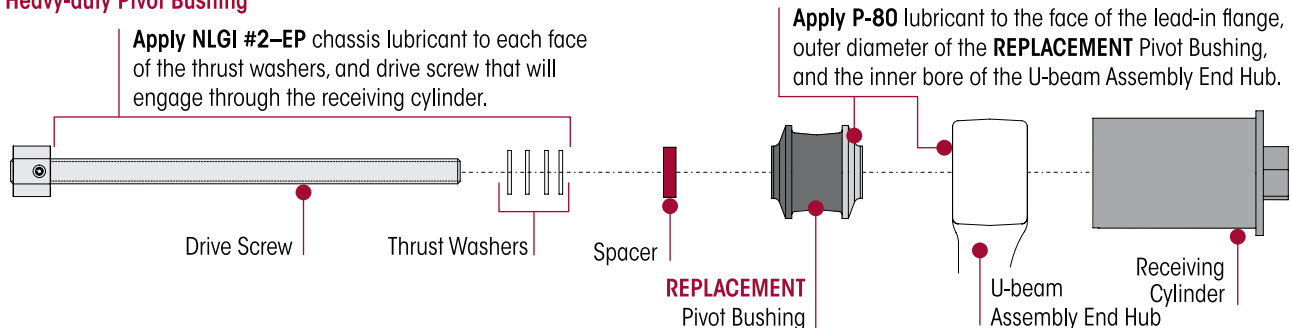
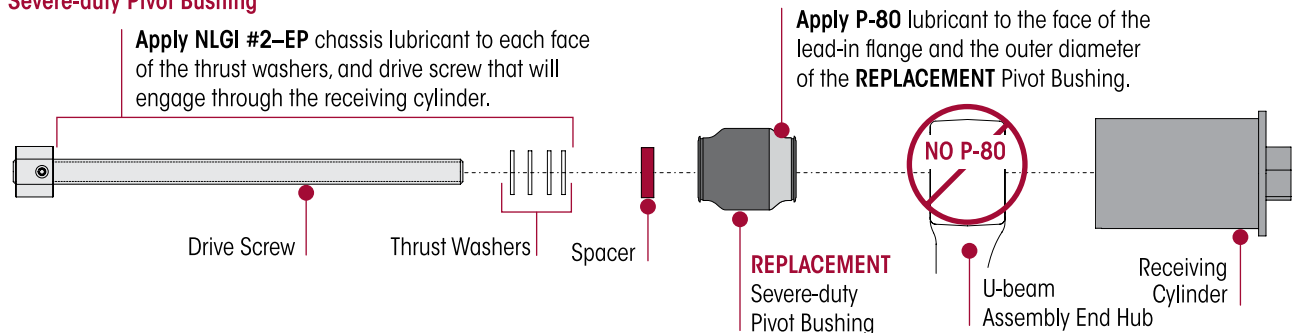

FIGURE 8-21
Severe-duty Pivot Bushing





NOTE

DO NOT use petroleum or soap based lubricant, it can cause an adverse reaction with the bushing material, such as deterioration. P-80 lubricant is supplied in the QUIK-ALIGN Pivot Bushing Kits.

3. Apply P-80 lubricant to the:
 - **Heavy-duty Pivot Bushing** – to the face of the lead-in flange, the outer diameter of the replacement pivot bushing, and the inner diameter of the U-beam assembly end hub, see Figure 8-20.
 - **Severe-duty Pivot Bushing** – the face of the lead-in flange and to the outer diameter of the severe-duty pivot bushing, see Figure 8-21. **DO NOT** apply to the U-beam end hub.
4. Snug the threaded drive screw to hold the thrust washers, spacer, pivot bushing, and the U-beam assembly with the receiving cylinder in place, see Figures 8-22 and 8-23.
5. Using a ¾" impact wrench, rotate the drive screw in a continuous motion without stopping until the pivot bushing is seated in the hub and slightly overshoots the opposite end of the hub. It is necessary to overshoot the desired final position, see Figures 8-24 and 8-25.
6. Remove and reverse the installation tool, then from the opposite side of the hub press the pivot bushing again to center the bushing within the beam end hub, see Figures 8-26 and 8-27. Center the pivot bushing to help prevent bulging and bushing preload. This is known as the "Bump Back" procedure.

FIGURE 8-22
Heavy-duty Pivot Bushing

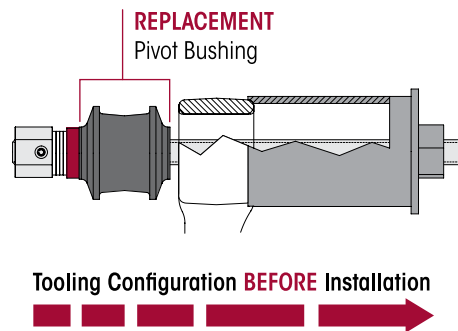

FIGURE 8-24
Heavy-duty Pivot Bushing

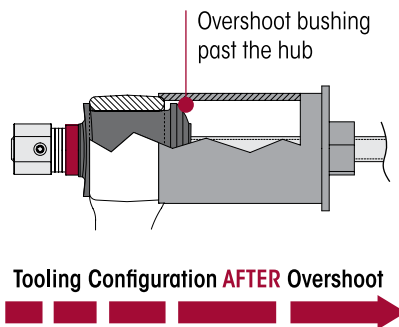

FIGURE 8-26
Heavy-duty Pivot Bushing

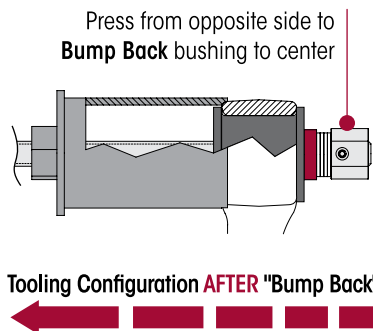

FIGURE 8-23
Severe-duty Pivot Bushing

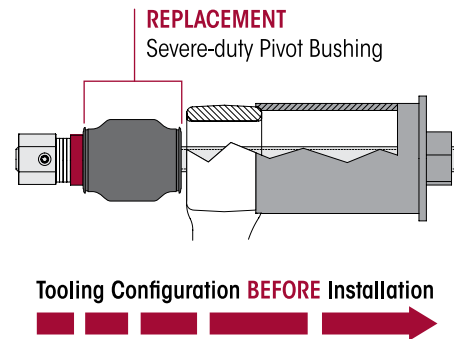

FIGURE 8-25
Severe-duty Pivot Bushing

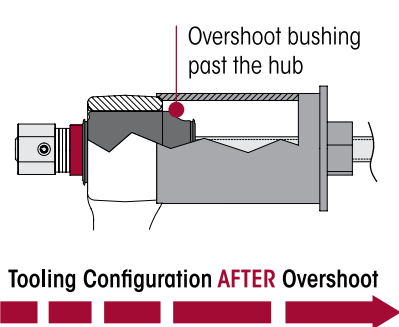
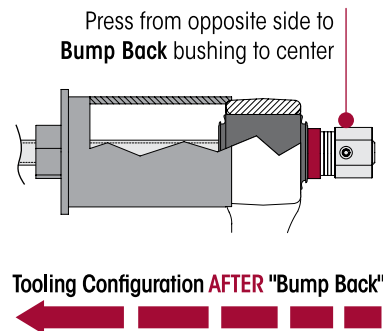

FIGURE 8-27
Severe-duty Pivot Bushing





SERVICE HINT

If the **severe-duty pivot bushing** comes out of the opposite end of the end hub during installation, less P-80 lubricant is required. Repeat the installation procedure, ensure only a light amount of lubricant is on the bushing itself.

7. **Severe-duty Pivot Bushings** – Snap the thrust washers onto the bushing. (see Figure 8-28) and ensure there is free play on both washers, see Figure 8-29. If one washer does not seat properly or is very snug use a dead blow hammer to center the bushing. If a dead blow hammer is not sufficient, the installation tool must be used to perform a secondary "Bump Back" procedure to center the bushing, refer to Step 6 and see Figures 8-26 and 8-27.

FIGURE 8-28

Severe-duty Pivot Bushing

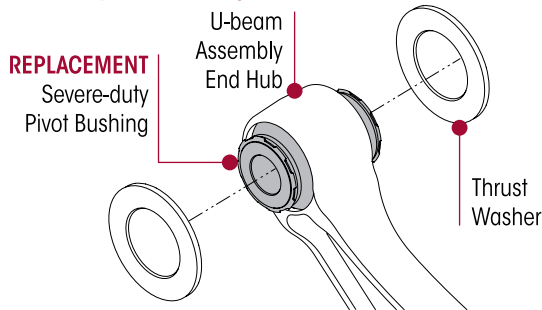
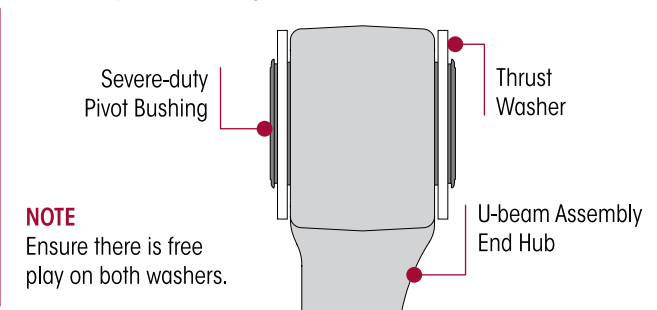

FIGURE 8-29

Severe-duty Pivot Bushing



8. Repeat for the other side of the U-beam assembly, as recommended:
 - **Heavy-duty Pivot Bushings** – Steps 1 through 6.
 - **Severe-duty Pivot Bushings** – Steps 1 through 7.
9. Allow the lubricant four (4) hours to dissipate before fully operating the vehicle.
10. Install the U-beam assembly, follow the installation procedure as detailed in this section.

TOP PAD

NOTE

Replace the top pad one side at time and ensure the opposite top remains connected when servicing. This preserve the pinion angle and facilitates installation.

DISASSEMBLY

1. Chock the front wheels.
2. Support the frame at ride height with safety stands.
3. Raise and support the axle being serviced.
4. Remove the wheel assembly per the vehicle manufacturer's instructions.
5. Disconnect the height control valve arm(s) from the linkage assembly, see vehicle manufacturer's instructions.



WARNING

PRIOR TO AND DURING DEFLATION AND INFLATION OF THE AIR SUSPENSION SYSTEM, ENSURE THAT ALL PERSONNEL AND EQUIPMENT ARE CLEAR FROM UNDER THE VEHICLE AND AROUND THE SERVICE AREA, FAILURE TO DO SO CAN CAUSE SERIOUS PERSONAL INJURY, DEATH, OR PROPERTY DAMAGE.



WARNING

SOME VEHICLE APPLICATIONS, SUCH AS VEHICLES EQUIPPED WITH OUTRIGGERS, RETAIN SOME AIR PRESSURE IN THE AIR SPRINGS AT ALL TIMES. PRIOR TO PERFORMING ANY MAINTENANCE, SERVICE, OR REPAIR OF THE SUSPENSION, VERIFY EACH AIR SPRING IS COMPLETELY DEFLATED. FAILURE TO DO SO COULD RESULT IN SERIOUS PROPERTY DAMAGE AND/OR SEVERE PERSONAL INJURY.

6. See additional Air Spring Cautions and Warnings in the Important Safety Notice section of this publication prior to deflating or inflating the air system.
7. Lower the height control valve arm(s) to exhaust the air in the air springs and deflate the rear suspension.



SERVICE HINT

Note the quantity of shims removed to maintain the correct pinion angle of the axle at assembly. Refer to the Alignment & Adjustments section of this publication.

- Remove and discard the longitudinal torque rod fasteners from the top pad connection and remove the shims (if equipped), see Figure 8-30.

SERVICE HINT

Due to certain pinion angle configuration the removal of the D-pin bolts may be necessary to access the U-bolt locknuts.

FIGURE 8-30

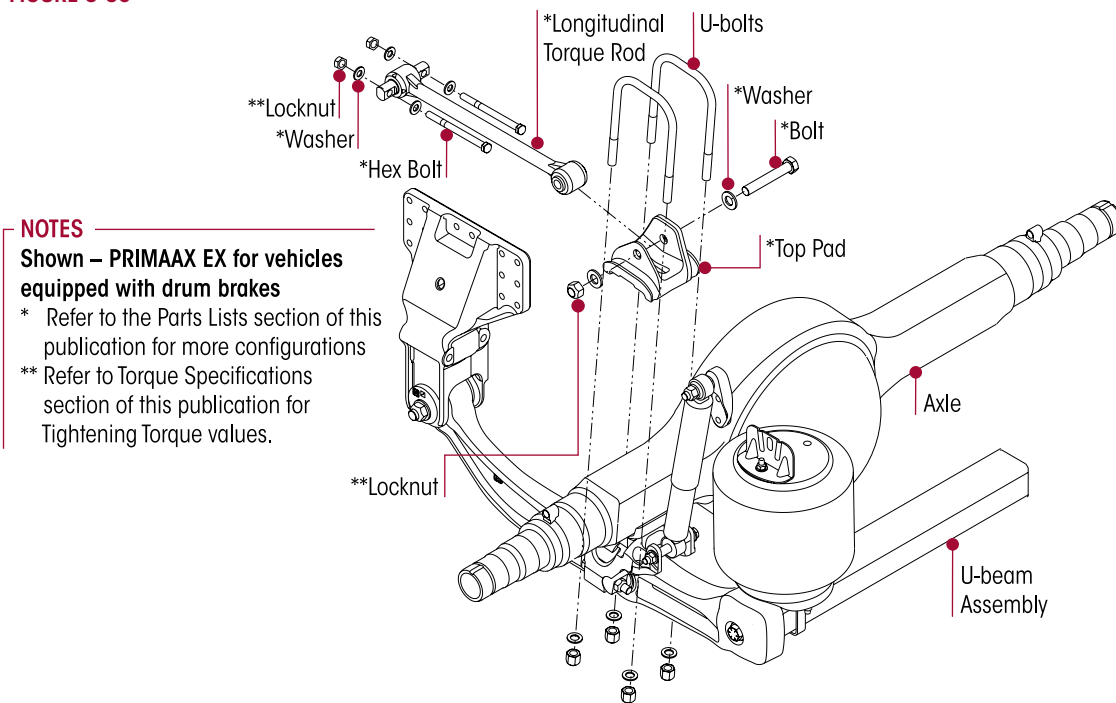

NOTES

Shown – PRIMAAX EX for vehicles equipped with drum brakes

* Refer to the Parts Lists section of this publication for more configurations

** Refer to Torque Specifications section of this publication for Tightening Torque values.



WARNING

USE ONLY A FLOOR JACK EQUIPPED WITH A FOUR INCH CONTACT PLATE TO SUPPORT THE U-BEAM ASSEMBLY AT THE CROSS TUBE TO FACILITATE SAFE LOWERING AND RAISING OF THE U-BEAM ASSEMBLY. DO NOT USE A BOTTLE JACK, WHICH DOES NOT HAVE ENOUGH CONTACT AREA AND CAN BE UNSTABLE. FAILURE TO DO SO CAN CAUSE COMPONENT DAMAGE OR RESULT IN PERSONAL INJURY.



WARNING

THE WEIGHT OF THE U-BEAM ASSEMBLY IS APPROXIMATELY 225 POUNDS. CARE SHOULD BE TAKEN AT REMOVAL AND INSTALLATION TO PREVENT PERSONAL INJURY OR DAMAGE TO COMPONENTS.

- Support the U-beam assembly with a floor jack that is equipped with a 4" contact plate.
- Remove and discard the U-bolt fasteners from the clamp group, see Figure 8-30.
- Remove the top pad.
- Inspect the top pad and the axle housing for any cracks or damage. Replace as necessary.

ASSEMBLY

- Install the top pad on the top of the axle engaging the dowel pin. Care should be taken to ensure the taller / thicker ear of the top pad is mounted to the inboard side of the suspension. The top pad varies with different models and may appear different, see Figure 8-31.
- Install new U-bolts and fasteners.

FIGURE 8-31

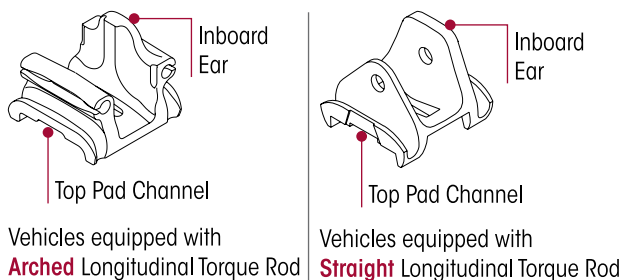



NOTE

Current Hendrickson Truck Suspension Systems U-bolt locknuts for the PRIMAAX EX suspensions are 3/4"-16 Grade C and are phosphate and oil coated.

3. Verify that the U-bolts are seated properly in the channels of the top pad, see Figure 8-30.
4. Tighten the U-bolt locknuts evenly in 50 foot pounds increments in the proper pattern to achieve uniform bolt tension, see Figure 8-32.
5. Rap the top of the U-bolts with a dead blow mallet, and retighten to the proper torque. **DO NOT** exceed specified torque on U-bolt locknuts. Tighten the 3/4" locknuts to 375 ± 25 foot pounds torque.
6. Tighten the 3/4" D-pin bolts to 300 ± 25 foot pounds torque, if loosened or removed during disassembly, see Figure 8-33.

FIGURE 8-32

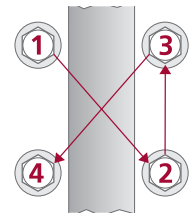
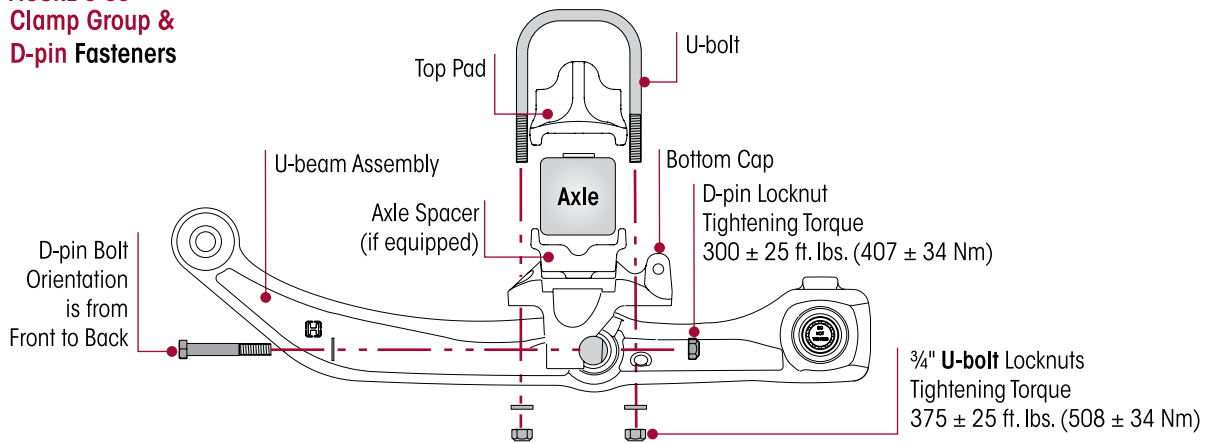

FIGURE 8-33
Clamp Group &
D-pin Fasteners



7. Remove the safety stand from U-beam assembly.
8. Install the fasteners on the longitudinal torque rod, **DO NOT** tighten at this time
9. See additional Air Spring Cautions and Warnings in the Important Safety Notice section of this publication prior to deflating or inflating the air system.
10. Connect the linkage assembly to the height control valve arm(s) to inflate the suspension.
11. Remove the frame safety stands.

NOTE

It is mandatory to have the vehicle at proper ride height prior to tightening the longitudinal torque rod fasteners to torque specifications.

12. Verify the vehicle is at proper ride height as per the vehicle manufacturer's specifications.
13. Tighten the longitudinal torque rod fasteners to the required specification, see the Torque Specifications section of this publication.
14. Install wheel assemblies per the vehicle manufacturer's instructions.
15. Remove axle support and lower the axle.
16. Remove the wheel chocks.



BOTTOM CAP AND AXLE SPACER (if equipped)

NOTE

It is not necessary to loosen the QUIK-ALIGN connection to service the bottom cap and axle spacer, therefore alignment is preserved during service. If the QUIK-ALIGN connection is loosened during service, alignment is required after service is completed.

DISASSEMBLY

1. Chock the front wheels.
2. Support the frame at ride height with safety stands.
3. Raise and support the axle being serviced.
4. Remove the wheel assembly per the vehicle manufacturer's instructions.
5. Disconnect the linkage assemblies from the height control valve arms, see vehicle manufacturer's instructions.

WARNING

PRIOR TO AND DURING DEFLATION AND INFLATION OF THE AIR SUSPENSION SYSTEM, ENSURE THAT ALL PERSONNEL AND EQUIPMENT ARE CLEAR FROM UNDER THE VEHICLE AND AROUND THE SERVICE AREA, FAILURE TO DO SO CAN CAUSE SERIOUS PERSONAL INJURY, DEATH, OR PROPERTY DAMAGE.

6. See additional Air Spring Cautions and Warnings in the Important Safety Notice section of this publication prior to deflating or inflating the air system.

WARNING

SOME VEHICLE APPLICATIONS, SUCH AS VEHICLES EQUIPPED WITH OUTRIGGERS, RETAIN SOME AIR PRESSURE IN THE AIR SPRINGS AT ALL TIMES. PRIOR TO PERFORMING ANY MAINTENANCE, SERVICE, OR REPAIR OF THE SUSPENSION, VERIFY EACH AIR SPRING IS COMPLETELY DEFLATED. FAILURE TO DO SO COULD RESULT IN SERIOUS PROPERTY DAMAGE AND/OR SEVERE PERSONAL INJURY.

7. Lower the height control valve arms to exhaust the air in the air springs and deflate the rear suspension.
8. Clean and lubricate the lower mounting fasteners of the air springs with penetrating oil. This will help prevent the air spring mounting studs from breaking during the removal process.
9. Remove the lower mounting fasteners from both air springs using **HAND TOOLS** only, refer to Air Spring in this section.

WARNING

USE ONLY A FLOOR JACK EQUIPPED WITH A FOUR INCH CONTACT PLATE TO SUPPORT THE U-BEAM ASSEMBLY AT THE CROSS TUBE TO FACILITATE SAFE LOWERING AND RAISING OF THE U-BEAM ASSEMBLY. DO NOT USE A BOTTLE JACK, WHICH DOES NOT HAVE ENOUGH CONTACT AREA AND CAN BE UNSTABLE. FAILURE TO DO SO CAN CAUSE COMPONENT DAMAGE OR RESULT IN PERSONAL INJURY.

WARNING

THE WEIGHT OF THE U-BEAM ASSEMBLY IS APPROXIMATELY 225 POUNDS. CARE SHOULD BE TAKEN AT REMOVAL AND INSTALLATION TO PREVENT PERSONAL INJURY OR DAMAGE TO COMPONENTS.

10. Support the U-beam assembly at the cross tube with a floor jack that is equipped with a four inch (4") contact plate.
11. Remove the lower shock absorber mounting fasteners from the side being serviced.
12. Remove and discard the D-pin fasteners from of the D-pin/bottom cap assembly on both side of the U-beam assembly.
13. Lower the floor jack to pivot the U-beam assembly down from the bottom caps.
14. Remove and discard the clamp group U-bolt fasteners.
15. Remove the bottom cap and the axle spacer (if equipped) from the axle.

ASSEMBLY

1. Install the top pad on the top of the axle engaging the dowel pin. Care should be taken to ensure the thicker / taller ear of the top pad is mounted to the inboard side of the suspension, see Figure 8-34.



2. Install the bottom cap and axle spacer (if equipped) on the axle in the proper direction, with the lower shock mounting holes facing the rear of the vehicle, see Figure 8-35.

FIGURE 8-34

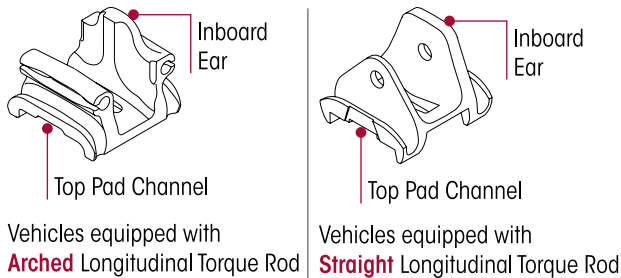
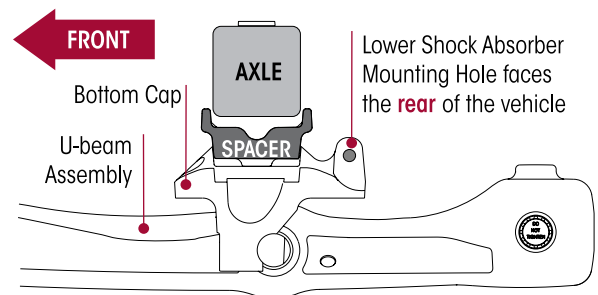

FIGURE 8-35



3. Install the new U-bolts. Verify that the U-bolts are seated properly in the top pad channels and through the bottom cap.

NOTE

Current Hendrickson Truck Suspension Systems U-bolt locknuts for the PRIMAAX EX / PRIMAAX suspension are 3/4"-16 Grade C and are phosphate and oil coated.



4. Install the new U-bolt fasteners and hand tighten, **DO NOT** tighten to torque at this time.

PRIOR TO TIGHTENING THE U-BOLTS TO THE FINAL TORQUE, ENSURE THE U-BEAM ASSEMBLY AND THE BOTTOM CAP ASSEMBLY ARE CENTERED ON THE AXLE ($A = B \pm 1/8"$), SEE FIGURE 8-36. FAILURE TO DO SO COULD CAUSE PREMATURE COMPONENT WEAR OR CAUSE UNEVEN LOAD DISTRIBUTION.

5. Center U-beam assembly and the bottom cap on the axle, ($A = B \pm 1/8"$), see Figure 8-36.

FIGURE 8-36

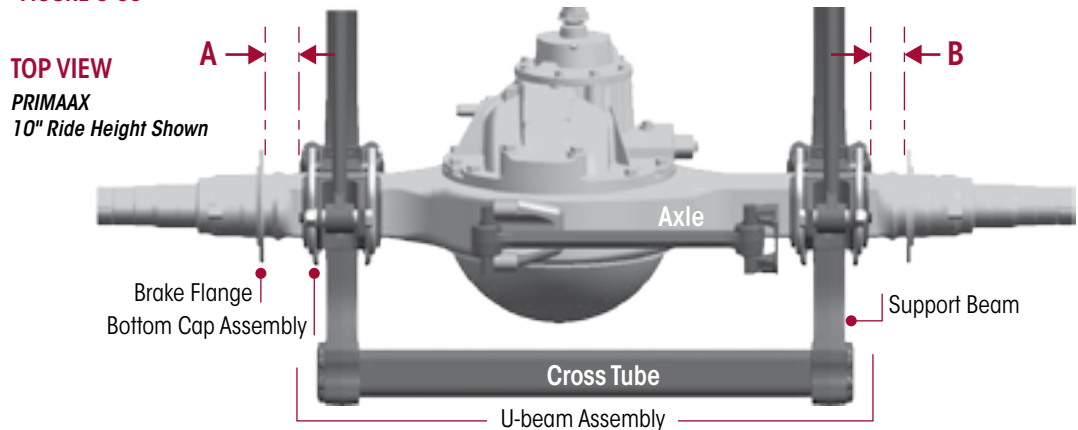

SERVICE HINT

It may be necessary to raise the front of the differential to allow the D-pins to engage the bottom cap.

6. Raise the U-beam assembly until the D-pins engage in the bottom cap.
7. Install D-pin fasteners with the bolt heads on the forward side of the bottom cap.
8. Lower the front differential to allow the full engagement of the D-pins into the bottom caps.
9. Prior to tightening the D-pin fasteners, verify the bottom cap is centered over the support beam.
10. Tighten the D-pin fasteners to $\boxed{300} \pm 25$ foot pounds torque.

11. Tighten the U-bolt locknuts evenly in 50 foot pounds increments in the proper pattern to achieve uniform bolt tension, see Figure 8-37.
12. Rap the top of the U-bolts with a dead blow mallet, and retighten to the proper torque. **DO NOT** exceed specified torque on U-bolt locknuts. Tighten the 3/4" locknuts to $\boxed{375} \pm 25$ foot pounds torque.

FIGURE 8-37

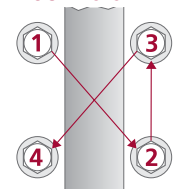



13. Pivot the shock back into the lower shock mount and install the lower shock absorber mounting fastener. Tighten the 5/8" locknuts to  213 ± 12 foot pounds torque.
14. Install the air spring between the frame and the cross tube, refer to Air Spring in this section.
15. Install the wheel assembly per the vehicle manufacturer's instructions.
16. Remove the safety stands and lower the frame of the vehicle.
17. See additional Air Spring Cautions and Warnings in the Important Safety Notice section of this publication prior to deflating or inflating the air system.
18. Connect the linkage assembly to the height control valve arm(s) to inflate the suspension.
19. Verify ride height per the vehicle instructions.
20. Remove the wheel chocks.

FRAME HANGER



THIS PROCEDURE TO REPLACE A FRAME HANGER MUST BE CONDUCTED WITH THE REMAINING FRAME HANGERS CONNECTED TO THE FRAME AND THE U-BEAM ASSEMBLY AND THE LONGITUDINAL TORQUE RODS. FAILURE TO DO SO COULD CAUSE THE AXLE TO SHIFT RESULTING IN POSSIBLE DAMAGE TO COMPONENTS OR PERSONAL INJURY.

SERVICE HINT

Increasing the pinion angle may facilitate the disassembly/assembly of the frame hanger. To increase the pinion angle place a floor jack under the axle pinion and raise slightly. This will increase the pinion angle slightly easing disassembly/assembly.

DISASSEMBLY

1. Chock the front wheels.
2. Support the frame at ride height with safety stands.
3. Raise and support the axle being serviced.
4. Remove the wheel assembly per the vehicle manufacturer's instructions.
5. Disconnect the height control valve arm(s) from the linkage assembly, see vehicle manufacturer's instructions.



PRIOR TO AND DURING DEFLATION AND INFLATION OF THE AIR SUSPENSION SYSTEM, ENSURE THAT ALL PERSONNEL AND EQUIPMENT ARE CLEAR FROM UNDER THE VEHICLE AND AROUND THE SERVICE AREA, FAILURE TO DO SO CAN CAUSE SERIOUS PERSONAL INJURY, DEATH, OR PROPERTY DAMAGE.

6. See additional Air Spring Cautions and Warnings in the Important Safety Notice section of this publication prior to deflating or inflating the air system.



SOME VEHICLE APPLICATIONS, SUCH AS VEHICLES EQUIPPED WITH OUTRIGGERS, RETAIN SOME AIR PRESSURE IN THE AIR SPRINGS AT ALL TIMES. PRIOR TO PERFORMING ANY MAINTENANCE, SERVICE, OR REPAIR OF THE SUSPENSION, VERIFY EACH AIR SPRING IS COMPLETELY DEFLATED. FAILURE TO DO SO COULD RESULT IN SERIOUS PROPERTY DAMAGE AND/OR SEVERE PERSONAL INJURY.

7. Lower the height control valve arm(s) to exhaust the air in the air springs and deflate the rear suspension.

SERVICE HINT

Each frame hanger will have a pair of QUIK-ALIGN collars. Any eccentric (with the square drive feature, see Figure 8-38) QUIK-ALIGN collar should be mounted on the outboard side of the frame hanger. Thrust angle for single and scrub for tandem equipped vehicles can only be corrected on frame hangers equipped with eccentric QUIK-ALIGN collars.

SERVICE HINT

Mark the position of the QUIK-ALIGN square drive in relation to the frame hanger with a paint stick prior to loosening the QUIK-ALIGN connection. This will facilitate the axle alignment process after the repair is complete.



- Remove the QUIK-ALIGN fasteners and collars, and note the orientation of the fasteners, see Figure 8-38. Discard the fasteners. The collars may be reused if they are not damaged.

FIGURE 8-38

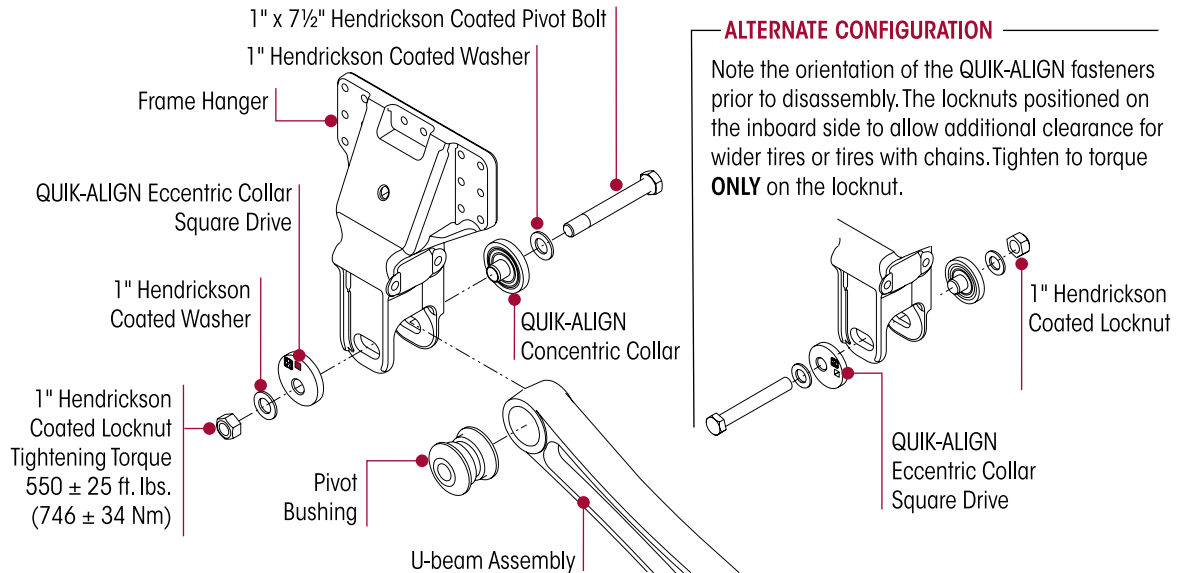

- Remove and discard the longitudinal torque rod fasteners that connect to the frame hanger

SERVICE HINT

Note the quantity of longitudinal shims removed to maintain the correct pinion angle of the axle at assembly. See Alignment & Adjustments section of this publication.

- Remove torque rod shims (if equipped) that connect to the frame hanger
- Remove and discard frame hanger fasteners that attach to the frame rail per the vehicle manufacturer's specifications.
- Remove the frame hanger.
- Inspect the frame rail mounting surface for any damage or wear.
- Inspect the QUIK-ALIGN pivot bushing and torque rod bushings for wear or damage, replace as necessary as detailed in this section.

ASSEMBLY

- Slide the new frame hanger over the QUIK-ALIGN pivot bushing.
- Install the new fasteners that attach the frame hanger to the vehicle and tighten per the vehicle manufacturer's specifications.



WARNING

DISCARD USED QUIK-ALIGN FASTENERS. ALWAYS USE NEW QUIK-ALIGN FASTENERS TO COMPLETE A REPAIR. FAILURE TO DO SO COULD RESULT IN FAILURE OF THE PART, OR MATING COMPONENTS, ADVERSE VEHICLE HANDLING, POSSIBLE PERSONAL INJURY, OR PROPERTY DAMAGE.



WARNING

DO NOT ASSEMBLE QUIK-ALIGN JOINT WITHOUT THE PROPER FASTENERS. USE ONLY HENDRICKSON COATED GENUINE FASTENERS TO SUSTAIN PROPER CLAMP FORCE. ENSURE THAT THE QUIK-ALIGN FASTENER'S TORQUE VALUES ARE SUSTAINED AS RECOMMENDED IN THE TORQUE SPECIFICATIONS SECTION OF THIS PUBLICATION. FAILURE TO FOLLOW THE ABOVE ITEMS CAN CAUSE ADVERSE VEHICLE HANDLING RESULTING IN PERSONAL INJURY OR PROPERTY DAMAGE AND WILL VOID ANY APPLICABLE WARRANTIES. FOLLOW VEHICLE MANUFACTURER'S FASTENER ORIENTATION WHEN PERFORMING ANY MAINTENANCE, SERVICE, OR REPAIR.

NOTE

Use a new QUIK-ALIGN pivot bolt kit (see the Parts List section of this publication) for any axle alignment or disassembly of the QUIK-ALIGN connection. This will help ensure that the proper clamp load is applied to the connection and help prevent the joint to slip in service.



3. Install the QUIK-ALIGN collars and the new mounting hardware that attach the U-beam assembly to the frame hanger, see Figure 8-38. Verify that the nose of each QUIK-ALIGN collar is installed correctly into the pivot bushing sleeve, and the flanged side is flat against the frame hanger face within the alignment guides. Snug QUIK-ALIGN locknuts to 50-100 foot pounds torque, **DO NOT** tighten at this time.
4. Install the torque rod mounting fasteners and reinstall any shims that were removed during disassembly. Tighten fasteners as per vehicle manufacturer's specifications.
5. See additional Air Spring Cautions and Warnings in the Important Safety Notice section of this publication prior to deflating or inflating the air system.
6. Connect the linkage assembly to the height control valve arm(s) to inflate the suspension.
7. Install the wheel assembly per the vehicle manufacturer's instructions.
8. Remove the axle supports and lower the axle.
9. Remove the safety stands from the vehicle frame.
10. Verify that the axle is in proper alignment, see the Alignment & Adjustments section of this publication.

NOTE

It is mandatory to have the vehicle at proper ride height prior to tightening the QUIK-ALIGN locknuts to torque specifications.

11. After the correct alignment of the axle is verified tighten the 1.0" QUIK-ALIGN locknuts to 550 ± 25 foot pounds torque.
12. Verify the correct pinion angle on the axle per the original equipment manufacturer's specifications. Adjust as necessary per the Alignment & Adjustments section of this publication.
13. Remove the chocks from the front wheels.

AXLE STOPS**DISASSEMBLY**

1. Chock the wheels.

SERVICE HINT

The axle stop fasteners secure the transverse torque rod to the inside of the frame rail. It may necessary to remove and replace one fastener at a time to facilitate axle stop replacement and help prevent the torque rod from shifting.

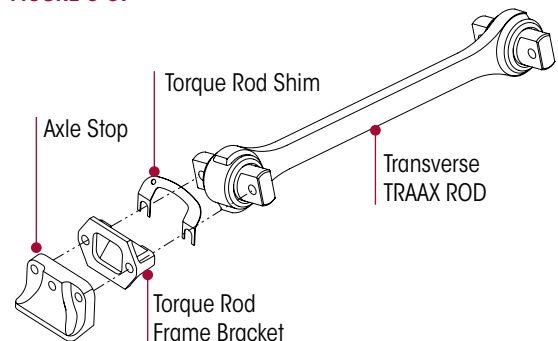
FIGURE 8-39

2. Remove the fasteners connecting the axle stop to the frame per the vehicle manufacturer's instructions.
3. Remove the axle stop, see Figure 8-39.
4. Inspect the frame rail mounting surfaces for any cracks or damage and replace or repair as necessary per the vehicle manufacturer's instructions.

ASSEMBLY

1. Install the axle stop on the outboard side of the frame rail with the torque rod frame bracket on the inboard side.
2. Install and tighten the new mounting fasteners per the vehicle manufacturer's installation and torque specifications.
3. Remove the wheel chocks.





SECTION 9 Torque Specifications

Hendrickson recommended torque values provided in Foot Pounds and in Newton Meters

PRIMAAX EX 23K • 46K • 69K
8½" • 10" Ride Height
 Vehicles built after April 2011

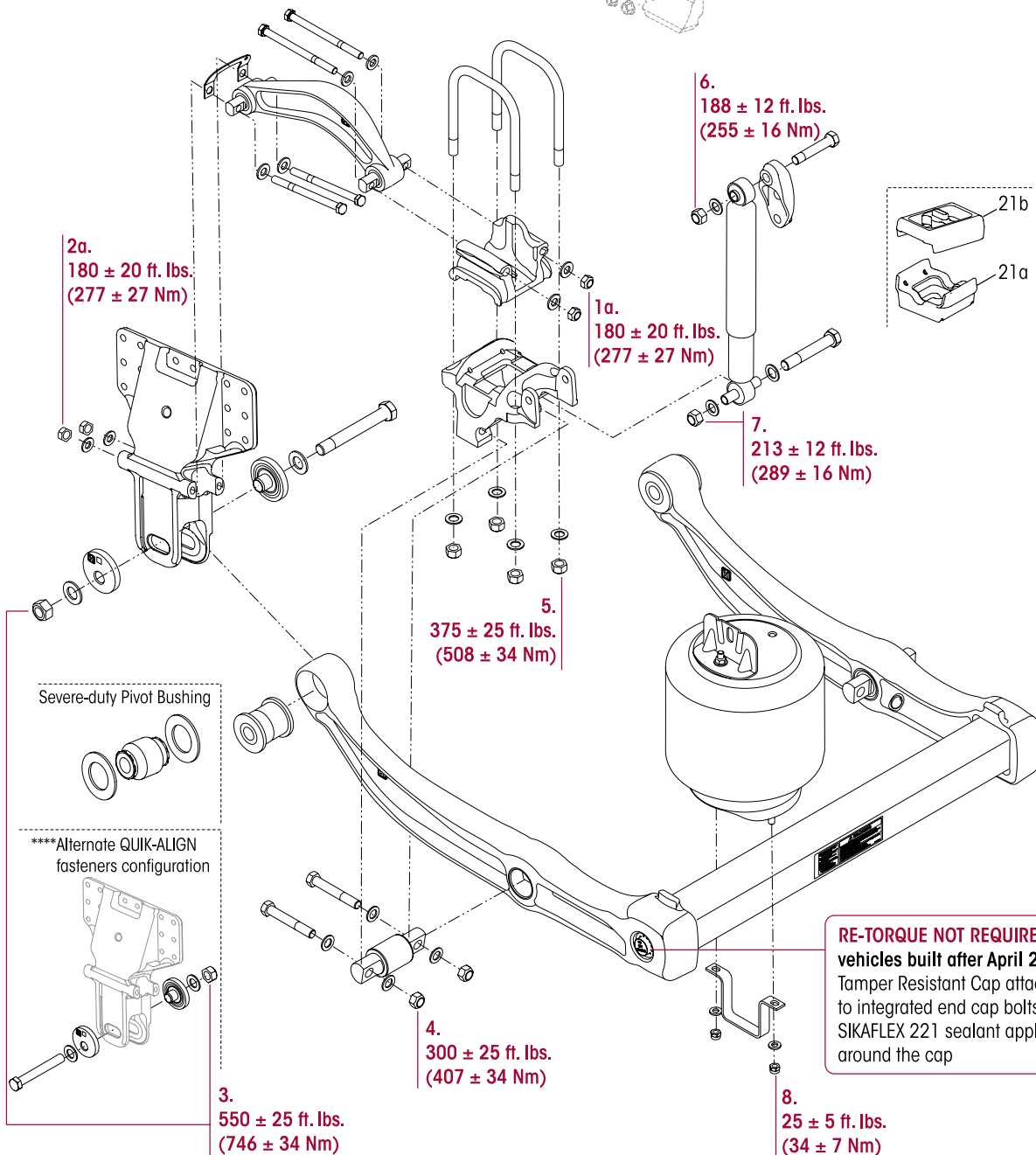
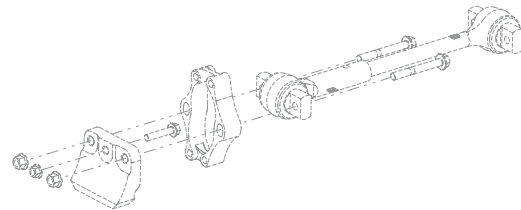
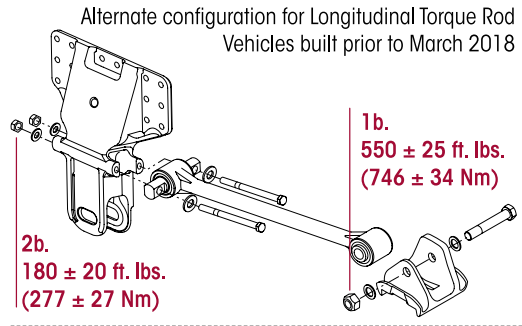

RE-TORQUE NOT REQUIRED for vehicles built after April 2011. Tamper Resistant Cap attached to integrated end cap bolts with SIKAFLEX 221 sealant applied around the cap



PRIMAAX EX for Volvo Vehicles

Vehicles built after April 2011 | Equipped with Air Disc Brakes / Drum Brakes

HENDRICKSON RECOMMENDED TORQUE SPECIFICATIONS

NO	COMPONENT	Fasteners		**TORQUE VALUE	
		*Quantity	Size	Foot Pounds	Newton Meter
Frame fasteners are furnished and installed by the vehicle manufacturer. Vehicle manufacturer may use an equivalent HUCK fastener at frame mount. See vehicle manufacturer for torque requirements.					
1	Longitudinal Torque Rod to Top Pad				
	a. Vehicles built after March 2018	4	5/8"-11 UNC	180 ± 20	277 ± 27
	b. Vehicles built prior to March 2018	2	7/8"-14 UNF	550 ± 25	746 ± 34
2	Longitudinal Torque Rod to Frame Hanger	2	5/8"-11 UNC	180 ± 20	277 ± 27
3	U-beam Assembly to QUIK-ALIGN Bushing	2	1"-14 UNF	550 ± 25	746 ± 34
4	U-beam Assembly to Center D-pin Bushing	4	3/4"-16 UNF	300 ± 25	407 ± 34
5	U-bolt Locknuts	8	3/4"-16 UNF	375 ± 25	508 ± 34
6	Upper Shock Absorber Locknuts	2	3/4"-10 UNC	188 ± 12	255 ± 16
7	Lower Shock Absorber Locknuts	2	5/8"-11 UNC	213 ± 12	289 ± 16
8	Lower Air Spring Bracket to Cross Tube	4	1/2"-13 UNC	25 ± 5	34 ± 7
<p>NOTE: * Quantities shown are per axle. Double for tandem, triple for tridem.</p> <p>** Torque values shown apply only if Hendrickson supplied fasteners are used. If non Hendrickson fasteners are used, follow the torque specification listed in vehicle manufacturer's service manual.</p>					



PRIMAAX 230 • 460 • 690 | 8½" • 10" Ride Height
 Vehicles built prior to April 2011

Hendrickson recommended torque values
 provided in Foot Pounds and in Newton Meters

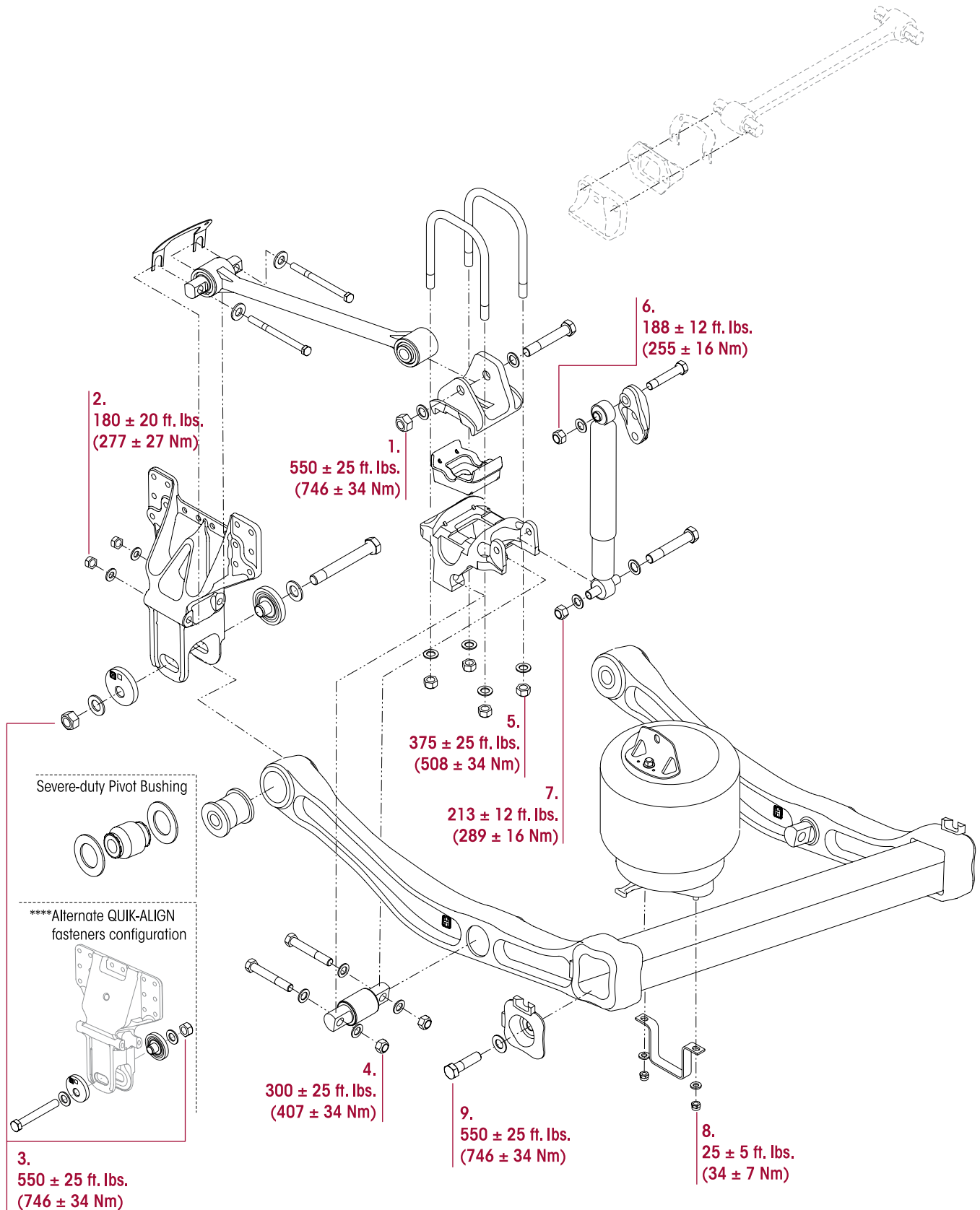



PRIMAAX for Volvo Vehicles

Vehicles built prior to April 2011 | Equipped with Drum Brakes

HENDRICKSON RECOMMENDED TORQUE SPECIFICATIONS

NO	COMPONENT	Fasteners		**TORQUE VALUE	
		*Quantity	Size	Foot Pounds	Newton Meter
Frame fasteners are furnished and installed by the vehicle manufacturer. Vehicle manufacturer may use an equivalent HUCK fastener at frame mount. See vehicle manufacturer for torque requirements.					
1	Longitudinal Torque Rod to Top Pad	2	7/8"-14 UNF	550 ± 25	746 ± 34
2	Longitudinal Torque Rod to Frame Hanger	2	5/8"-11 UNC	180 ± 20	277 ± 27
3	U-beam Assembly to QUIK-ALIGN Bushing	2	1"-14 UNF	550 ± 25	746 ± 34
4	U-beam Assembly to Center D-pin Bushing	4	3/4"-16 UNF	300 ± 25	407 ± 34
5	U-bolt Locknuts	8	3/4"-16 UNF	375 ± 25	508 ± 34
6	Upper Shock Absorber Locknuts	2	3/4"-10 UNC	188 ± 12	255 ± 16
7	Lower Shock Absorber Locknuts	2	5/8"-11 UNC	213 ± 12	289 ± 16
8	Lower Air Spring Bracket to Cross Tube	4	1/2"-13 UNC	25 ± 5	34 ± 7
9	U-beam Assembly to Cross Tube End Cap	2	7/8"-9 UNC	550 ± 25	746 ± 34
<p>NOTE: * Quantities shown are per axle. Double for tandem, triple for tridem.</p> <p>** Torque values shown apply only if Hendrickson supplied fasteners are used. If non Hendrickson fasteners are used, follow the torque specification listed in vehicle manufacturer's service manual.</p>					



SECTION 10

Troubleshooting Guide

PRIMAAX EX for Volvo Vehicles

TROUBLESHOOTING GUIDE		
CONDITION	POSSIBLE CAUSE	CORRECTION
Suspension has harsh or bumpy ride	Air spring is not inflated to specification or damaged	Repair air system and check ride height as per the vehicle manufacturer's specifications.
	Ride height set incorrectly	Adjust ride height to proper setting as per the vehicle manufacturer's specifications.
	Suspension is overloaded	Redistribute the load to correct the weight.
	Broken support beam	Replace the broken U-beam assembly.
Irregular tire wear	Incorrect tire inflation pressure	Correct tire pressure per vehicle manufacturer and tire manufacturer specifications.
	Incorrect alignment	Correct the alignment. Refer to the Alignment & Adjustments section of this publication.
	Worn QUIK-ALIGN bushing	Replace the QUIK-ALIGN bushing.
	Loose QUIK-ALIGN attachment	Replace the QUIK-ALIGN connection, and check vehicle alignment. Adjust if necessary. Check frame hanger for wear around QUIK-ALIGN plates and replace if necessary.
	Worn torque rod bushings	Replace the torque rod bushings as necessary.
Excessive driveline vibration	Incorrect pinion angle(s)	Adjust the pinion angle(s), refer to vehicle manufacturer for specifications.
	Loose QUIK-ALIGN attachment	Replace the QUIK-ALIGN connection, and check the vehicle alignment. Adjust if necessary. Check the frame hanger for wear around the QUIK-ALIGN collars and replace if necessary.
	Ride height is set incorrectly	Adjust the ride height to proper setting as per the vehicle manufacturer's specifications.
	Broken support beam	Replace the U-beam assembly.
Suspension is noisy	Loose QUIK-ALIGN connection	Replace QUIK-ALIGN connection, and check vehicle alignment. Adjust if necessary. Check frame hanger for wear around QUIK-ALIGN plates and replace if necessary.
	Loose U-bolts	Tighten the U-bolts to specifications, see Torque Specifications section of this publication.
	Worn bushings	Replace the bushings or component as necessary.
Vehicle is bouncing excessively	Damaged or leaking shock absorber	Replace the shock absorber.
	Ride height set incorrectly	Adjust the ride height to proper setting as per the vehicle manufacturer's specifications.



PRIMAAX EX for Volvo Vehicles

TROUBLESHOOTING GUIDE (CONTINUED)

CONDITION	POSSIBLE CAUSE	CORRECTION
Vehicle leaning	Air spring not inflated to specification or damaged	Repair the air system and check the ride height per the vehicle manufacturer's specifications.
	Load not centered	Redistribute the load.
	Frame twisted	Straighten the frame per vehicle manufacturer's guidelines.
	Broken support beam	Replace the broken U-beam assembly.
	Axle housing bent or broken	Replace the axle housing per vehicle manufacturer guidelines and align the vehicle.
	Loose U-bolts	Tighten the U-bolts to specification, see U-bolt Fasteners in the Preventive Maintenance section of this publication.
	Front suspension	Inspect and repair the front suspension.
Suspension will not reach ride height	Suspension is overloaded	Redistribute the load to the correct weight.
	Air Spring leaking or damaged	Replace the air spring.
	Leak in the air system	Inspect the air fittings, see Air Fitting in the Preventive Maintenance section of this publication. If necessary, repair air system and check ride height as per the vehicle manufacturer's specifications.
	Air line obstructed or improperly connected	Repair the air system and check the ride height as per the vehicle manufacturer's specifications.
	Height control valve dump port activated	Check the height control valve dump port for proper connection and function.
Air springs deflate when parked	Leak in the air system	Inspect air fittings, see Air Fitting in the Preventive Maintenance section of this publication. If necessary, repair the air system and check the ride height as per the vehicle manufacturer's specifications.
	Malfunctioning height control valve	See the test procedure in the Preventive Maintenance section, replace height control valve as necessary.
Excessive frame slope	Ride height set incorrectly	Adjust the ride height to proper setting as per the vehicle manufacturer's specifications.
	Suspension is overloaded	Redistribute the load to correct weight.





Actual product performance may vary depending upon vehicle configuration, operation, service and other factors.
All applications must comply with applicable Hendrickson specifications and must be approved by the respective vehicle manufacturer with the vehicle in its original, as-built configuration.
Contact Hendrickson for additional details regarding specifications, applications, capacities, and operation, service and maintenance instructions.

*Call Hendrickson at **1.866.755.5968** (toll-free) or **1.630.910.2800** for additional information.*



www.hendrickson-intl.com

TRUCK COMMERCIAL VEHICLE SYSTEMS

800 South Frontage Road
Woodridge, IL 60517-4904 USA
1.866.755.5968 (Toll-free U.S. and Canada)
1.630.910.2800 (Outside U.S. and Canada)
Fax 1.630.910.2899

17730-254 Rev E 12-23

© 2012-2023 Hendrickson USA, L.L.C. All Rights Reserved. All trademarks shown are owned by Hendrickson USA, L.L.C., or one of the affiliates, in one or more countries.

Information contained in this literature was accurate at the time of publication. Product changes may have been made after the copyright date that are not reflected.

Printed in United States of America