

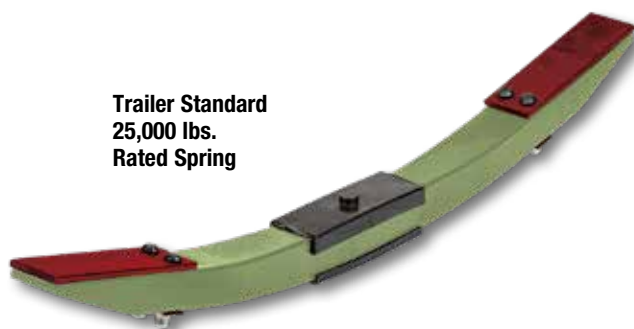

Hendrickson's engineered precision of LITEFLEX® composite springs deliver a product where manufacturers, fleets and owner-operators can benefit from an improved ride, reduction in weight, lower maintenance, increased load capacity and durability. LITEFLEX springs are corrosion resistant, maintain ride height, and provide improved vibration and harshness feedback. Hendrickson's LITEFLEX composite springs are a proven choice for today's short- and long-haulers.

Trailer



Trailer Standard
25,000 lbs.
Rated Spring

- Reduces weight when compared to conventional steel springs
- A low-cost composite and lightweight suspension option
- Increases capacity for greater loads
- 5-year / 500,000 mile limited warranty*
- Advanced, lightweight design to help reduce fuel consumption

PART NUMBER	SUSPENSION MODEL
21607-01	Reyco
16316-01	Hutchens

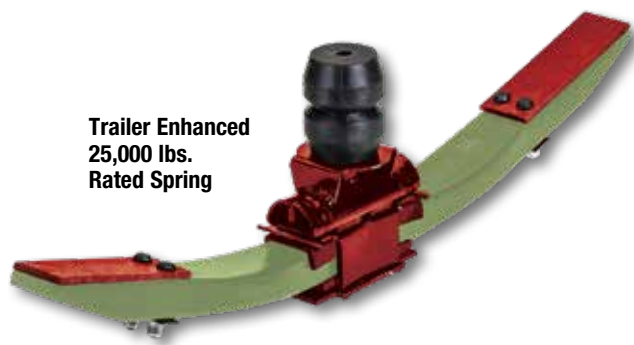

Trailer Enhanced
25,000 lbs.
Rated Spring

- Provides a similar ride to air suspensions and gives a significantly better ride than conventional steel springs
- Reduces weight when compared to air suspensions and costs less
- Helps reduce maintenance costs and intervals
- 5-year / 500,000 mile limited warranty*
- Advanced, lightweight design to help reduce fuel consumption

* Contact your local Hendrickson representative for complete warranty terms, conditions and limitations.

Our innovative products are currently produced for major North American and European OEMs, as well as multiple automotive and large truck and trailer applications in Asia.

PART NUMBER	SUSPENSION MODEL
11173	Hutchens with 5 in. axle
11174	Reyco with 5 in. axle
11175	SAF Holland without disc brakes and 5 in. axle
10996	SAF Holland with disc brakes and 5.75 in. axle
11220	Hutchens with 5.75 in. axle

Automotive

Hendrickson composite springs for the passenger and light truck segments enjoy many unique benefits over conventional steel springs. Among them is weight reduction for improved range, improved ride and comfort versus steel springs and corrosion resistance. Our springs offer manufacturers better packaging with systems requiring less space, allowing for lower hood lines, elimination of coil towers and oftentimes lower drag coefficients. It can also provide for larger interior space and / or the addition of more passenger amenities without adding to the overall vehicle weight.



Medium-Duty – Class 3 to 7

Hendrickson composite transverse springs create space by reducing traditional suspension towers and weight with composite materials requiring smaller / lighter support structures, like stabilizer bars. The result is less weight and increased hauling ability. Hendrickson hybrid composite springs can be packaged within the same packaging envelope as current multi-leaf spring packs. Potentially requiring no or minimal changes to the suspension package, allowing for easier integration. OEMs enjoy composite springs that are lighter than their steel equivalents. This weight savings allow the manufacturers to improve efficiency while increasing capacity limits.



Heavy-Duty – Class 8

Hendrickson composite springs are lighter than conventional steel springs, helping to improve fuel economy and payload capacity. They are corrosion resistant, maintain ride height and provide improved vibration and harshness feedback. Hendrickson composite springs are a proven option for manufacturers and owners around the globe.



Actual product performance may vary depending upon vehicle configuration, operation, service and other factors.
All applications must comply with applicable Hendrickson specifications and must be approved by the respective vehicle manufacturer with the vehicle in its original, as-built configuration.
Contact Hendrickson for additional details regarding specifications, applications, capacities, operation, service and maintenance instructions.

Call Hendrickson at **630.910.2800** or **855.RIDERED (743.3733)** for additional information.



TRUCK COMMERCIAL VEHICLE SYSTEMS
800 South Frontage Road
Woodridge, IL 60517-4904 USA
855.RIDERED (743.3733)
630.910.2800 • Fax 630.910.2899

www.hendrickson-intl.com     

45745-526 Rev C 02-25

© 2021 - 2025 Hendrickson USA, L.L.C. All Rights Reserved. All trademarks shown are owned by Hendrickson USA, L.L.C., or one of its affiliates, in one or more countries. Information contained in this literature was accurate at the time of publication. Product changes may have been made after the copyright date that are not reflected. Printed in United States of America