

# **H** TECHNICAL PROCEDURE

## HENDRICKSON TRAILER AXLES

**SUBJECT:** Service Procedures

**LIT NO:** L1061

**DATE:** January 2009



---

### TABLE OF CONTENTS

|  |    |
|--|----|
| INTRODUCTION .....                           | 2  |
| SAFETY PRECAUTIONS .....                     | 3  |
| AXLE IDENTIFICATION .....                    | 4  |
| AXLE INSTALLATION .....                      | 9  |
| TRAILER AXLE ALIGNMENT .....                 | 10 |
| GENERAL WELDING RECOMMENDATIONS .....        | 11 |
| WHEEL BEARINGS .....                         | 13 |
| RECOMMENDED BRAKE ADJUSTMENT PROCEDURE ..... | 15 |
| BRAKE DISASSEMBLY / ASSEMBLY .....           | 16 |
| WELDING ABS WHEEL SPEED SENSOR BLOCKS .....  | 18 |
| TORQUE SPECIFICATIONS .....                  | 19 |
| SUGGESTED PREVENTATIVE MAINTENANCE .....     | 19 |

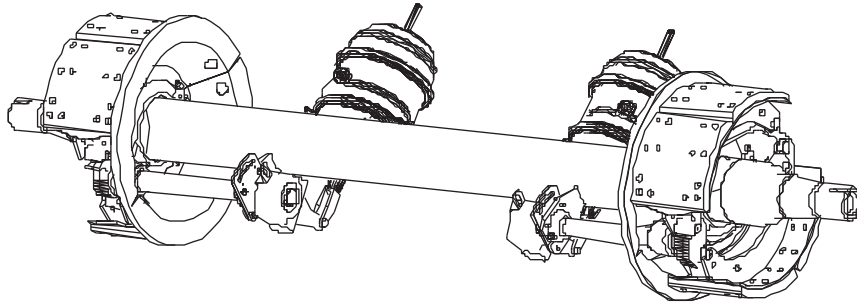

*HN (D22) Straight Axle*

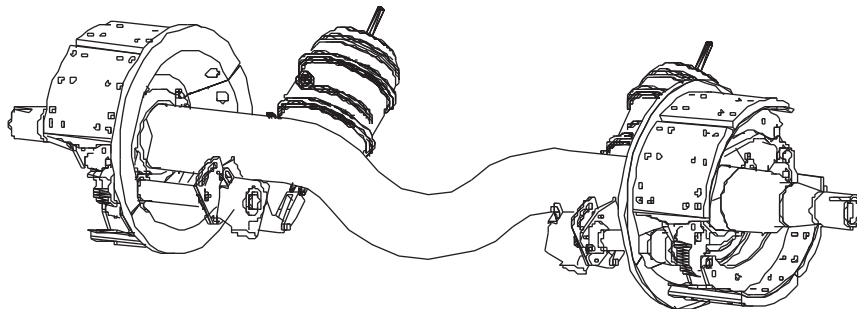

*HN (D22) Bent or Drop Center Axle*

## INTRODUCTION

Hendrickson presents this publication to aid in understanding the Hendrickson Trailer Axle and its application requirements. Hendrickson Trailer Axles are engineered to meet the demanding requirements of the industry and incorporate the latest design and manufacturing technologies. This manual is provided to help maintain the safety, dependability and performance designed into Hendrickson trailer products. Read this manual carefully before you perform installation or maintenance procedures.

You will find DANGER, WARNING, CAUTION and NOTE symbols and statements throughout this manual.

**⚠ DANGER:** INDICATES IMMEDIATE HAZARDS WHICH WILL RESULT IN SEVERE PERSONAL INJURY OR DEATH.

**⚠ WARNING:** INDICATES HAZARDS OR UNSAFE PRACTICES WHICH COULD RESULT IN SEVERE PERSONAL INJURY OR DEATH.

**⚠ CAUTION:** Indicates hazards or unsafe practices which could result in damage to machine or minor personal injury.

**NOTE:** Indicates that you must do something in order for the axle or brake to function properly.

If you have any questions about this manual or its instructions, contact Hendrickson Trailer Suspension Systems at 1-866-RIDEAIR (743-3247).



## SAFETY PRECAUTIONS

- ⚠ WARNING: BEFORE PERFORMING ANY MAINTENANCE OR REPAIR WORK REQUIRING RAISING OF VEHICLE, ENSURE VEHICLE IS PROPERLY SUPPORTED WITH LIFT STANDS OF SUFFICIENT RATED CAPACITY. DO NOT RELY ON JACKS ALONE FOR SUPPORT OF VEHICLE.**
- ⚠ WARNING: SAFETY GLASSES SHOULD BE WORN AT ALL TIMES WHEN ASSEMBLING OR DISASSEMBLING AXLES AND THEIR COMPONENTS.**
- ⚠ WARNING: A SERIOUS OR FATAL INJURY CAN OCCUR IF YOU...**
- LACK PROPER TRAINING
  - FAIL TO FOLLOW PROPER PROCEDURES
  - DO NOT USE PROPER TOOLS AND SAFETY EQUIPMENT
  - ASSEMBLE AXLE COMPONENTS IMPROPERLY
  - USE INCOMPATIBLE AXLE COMPONENTS
  - USE AXLES OR AXLE COMPONENTS IN A NON-APPROVED APPLICATION
- ⚠ WARNING: THIS MANUAL CONTAINS DETAILED SAFETY INSTRUCTIONS. READ, UNDERSTAND AND FOLLOW THIS MANUAL.**
- GET PROPER TRAINING
  - LEARN AND FOLLOW SAFE OPERATING PROCEDURES
  - USE PROPER TOOLS AND SAFETY EQUIPMENT
  - USE PROPER COMPONENTS THAT ARE IN GOOD CONDITION



## AXLE IDENTIFICATIONS

Standard Hendrickson Trailer Axles are available in various spindle and tube combinations and are designed for on-highway use. Axles are available in straight, drop- or raised-center axles and can be ordered fully dressed with hubs and brake drums (as shown in figures). Other miscellaneous components such as slack adjusters, air chambers, cam tubes, etc. can also be specified.



*Straight Axle*



*Drop-center Axle or Raised-center axle*

## STANDARD PRODUCT OFFERINGS

The part number, a description, and a serial number are all imprinted on a tag that is attached to the axle beam center (as shown in figure 1). The part number is used to identify the axle specifications. This number should be referred to when contacting Hendrickson to determine the appropriate service parts. The serial number is used to identify a particular axle along with all of the component parts as specified by the customer at the time of order. The axle description serves as a generic description of the axle assembly and can be used to determine some specific axle configuration parameters.

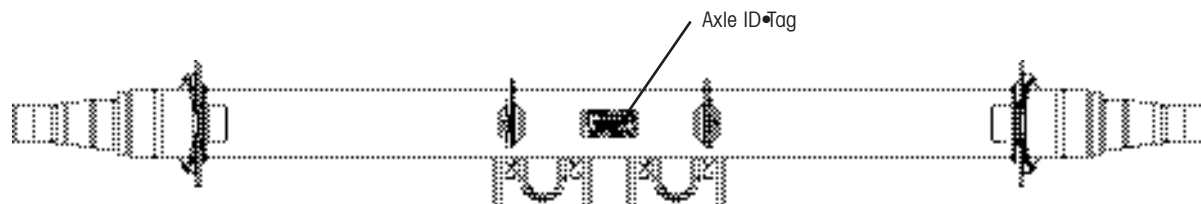

*Figure 1*

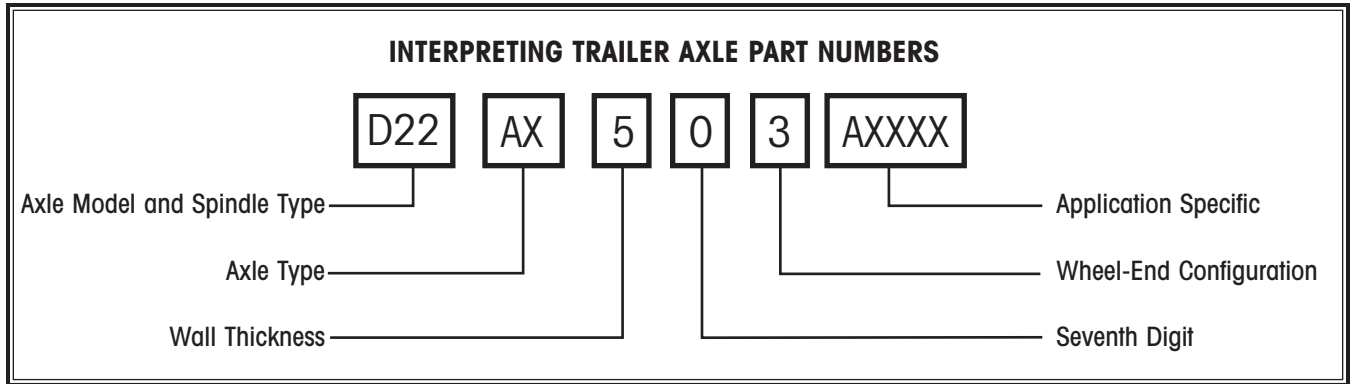

## AXLE MODEL AND SPINDLE TYPE

- A45 - Tapered spindle, solid bar
- A65 - Tapered spindle, solid bar
- D10 - Tapered spindle
- D22 (HN) - Tapered spindle
- K22 - Tapered spindle, press-up
- S22 - Tapered spindle, solid bar
- K30 - Tapered spindle, press-up
- S30 - Tapered spindle, solid bar
- P22 (HP) - Proper style spindle
- T24 - Drive axle / Truck spindle

## AXLE TYPE

- AX - Straight axle
- AU - Bent-tube (drop-center) axle
- AD - Straight axle, air disc brake

## WALL THICKNESS

- 1 - Stub axle (an axle cut in half) right
- 2 - Stub axle (an axle cut in half) left
- 3 - Stub axle (an axle cut in half) ambidextrous
- 5 - 1/2" wall thickness, 5.00" OD
- 6 - 5/8" wall thickness, 5.00" OD
- 7 - 3/4" wall thickness, 5.00" OD
- 8 - Solid bar

## SEVENTH DIGIT

- 0 - Standard trailer axle
- 1 - iPAC suspension axle, no longer used
- 2 - AdVANtage suspension axle
- 5 - Nominal 1/2" wall stub axle
- 6 - Nominal 5/8" wall stub axle
- 7 - Nominal 3/4" wall stub axle
- 8 - Machined from solid bar stub axle
- H - 5/8" HD wall

## WHEEL-END CONFIGURATION

- 0 - With spider / flanges, no brakes, hubs or drums
- 1 - With brakes, hubs and drums
- 2 - With spiders / flanges and hubs, no brake drums
- 3 - With brakes, no hubs or drums
- 4 - With hubs, no spiders / flanges or brakes
- 5 - No spiders / flanges, brakes, hubs or drums

## NINTH DIGIT

- A - Assemble to order options are picked at the time of placing the axle order. Options include brake shoe lining, ABS sensor installation and brand selection. Assemble to order options are for double anchor pin (DAP) axles only.

## TENTH DIGIT UP

- Axle specific - Numbers are sequential and are used to record the bill of material for each axle

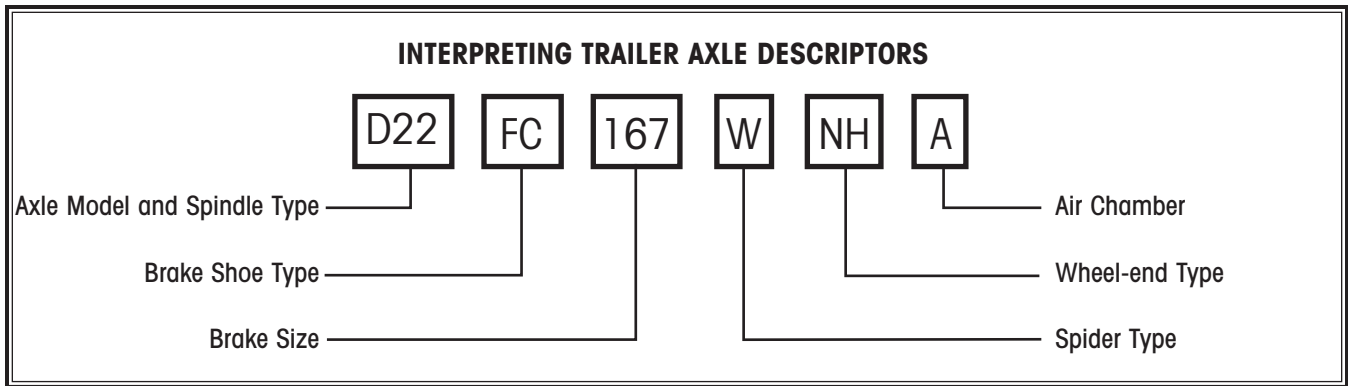

**AXLE MODEL AND SPINDLE TYPE**

- A45 - Tapered spindle, solid bar
- A65 - Tapered spindle, solid bar
- D10 - Tapered spindle
- D22 (HN) - Tapered spindle
- K22 - Tapered spindle, press-up
- S22 - Tapered spindle, solid bar
- K30 - Tapered spindle, press-up
- S30 - Tapered spindle, solid bar
- P22 (HP) - Proper style spindle
- T24 - Drive axle / Truck spindle

**BRAKE SHOE TYPE**

- CS - Cast shoe
- FB - Fabricated, bolted lining
- FC - Fast change fabricated
- FCXX - Fast change Xtra Life II
- FT - Fabricated, tapered
- N - No brakes, flanges spiders
- NBW - No brakes, with spiders
- NB - No brakes, with flanges
- ADB - Air disc brakes

**BRAKE SIZE**

- 123 - 12<sup>1</sup>/<sub>4</sub>" X 3"
- 1235 - 12<sup>1</sup>/<sub>4</sub>" X 3<sup>1</sup>/<sub>2</sub>"
- 1250 - 12<sup>1</sup>/<sub>4</sub>" X 5"
- 1255 - 12<sup>1</sup>/<sub>4</sub>" X 5<sup>1</sup>/<sub>2</sub>"
- 1275 - 12<sup>1</sup>/<sub>4</sub>" X 7<sup>1</sup>/<sub>2</sub>"
- 153 - 15" X 3"
- 154 - 15" X 4"
- 155 - 15" X 5"
- 157 - 15" X 7"
- 1586 - 15" X 8<sup>5</sup>/<sub>8</sub>"
- 165 - 16<sup>1</sup>/<sub>2</sub>" X 5"
- 166 - 16<sup>1</sup>/<sub>2</sub>" X 6"
- 167 - 16<sup>1</sup>/<sub>2</sub>" X 7"
- 1680 - 16<sup>1</sup>/<sub>2</sub>" X 8"
- 1686 - 16<sup>1</sup>/<sub>2</sub>" X 8<sup>5</sup>/<sub>8</sub>"
- 1610 - 16<sup>1</sup>/<sub>2</sub>" X 10"
- 187 - 18" X 7"
- 208 - 20" X 8"

**SPIDER TYPE**

- B - Bolt-on
- F - Flanges only (for bolt-on)
- W - Weld on

**WHEEL-END TYPE**

- NH - No hub or wheel
- W - Cast spoke wheel
- WD - Cast spoke wheel and drum
- B6 - 6 stud 8<sup>3</sup>/<sub>4</sub> BC hubs
- B8 - 8 stud 6<sup>1</sup>/<sub>2</sub> BC hubs
- B10 - 10 stud 11<sup>1</sup>/<sub>4</sub> BC hubs
- B13 - 10 stud 13<sup>3</sup>/<sub>16</sub> BC hubs
- B18 - 10 stud 8<sup>3</sup>/<sub>4</sub> BC hubs
- SW6 - 6 stud 8<sup>3</sup>/<sub>4</sub> BC hubs
- SW8 - 8 stud 6<sup>1</sup>/<sub>2</sub> BC hubs
- SW10 - 10 stud 11<sup>1</sup>/<sub>4</sub> BC hubs

**AIR CHAMBER**

- A - Air chambers mounted on axle



## TRLAXLE MODEL NUMBERS

In June 2008, Hendrickson announced the implementation of a new configuration system for nonintegrated trailer axles called TRLAXLE. Your customer service representative will be able to create a TRLAXLE model number and provide a price on most HN (D22) and HP (P22) axles when you send in your completed *Axle Ordering Guide* (L964) or *Electronic Axle Ordering Guide* (E964). Other specialty axles (drop- or raised-center axles, A45/A65, K22/K30, D10/D21 and T24) will continue to use their current model number designations, like D22AU603A2-2 or K30AX603A22-2.

Most HN and HP axle specs will be converted to new TRLAXLE.### model numbers. In most cases, the TRLAXLE bill of material will be identical to the D22 or P22, except with following component changes, if applicable:

- Stemco Guardian or Voyager will be the standard seal replacing Chicago Rawhide
- Abex 3030-197 brake lining will become the standard brake lining; Spicer Silver Supreme and Haldex brake linings are being discontinued
- Hendrickson's patented axle filter will become standard on all axles
- New configurations will require specifying (1) slacks only, (2) both slacks and chambers or (3) neither slacks or chambers; we cannot configure chambers only
- ABS sensors on drum brake specs will be 90 degrees, not straight
- ABS sensors on air disc brake specs will be straight, not 90 degrees
- Castellated nuts will not be configurable and must be ordered separately

In general, the TRLAXLE product will allow all of the same standards and options currently available on INTRAAX, such as:

- Hendrickson proprietary wheel-end packages: HVS (3-year limited warranty), HLS (5-year limited warranty) and HUS® (7-year limited warranty)
- TIREMAAX® CP and EC
- Brake sizes, plus 12<sup>1</sup>/<sub>4</sub>" x 7<sup>1</sup>/<sub>2</sub>", 12<sup>1</sup>/<sub>4</sub>" x 5<sup>1</sup>/<sub>2</sub>" and 12<sup>1</sup>/<sub>4</sub>" x 5"
- Brake lining options

In addition to a new TRLAXLE model number, Hendrickson made the axle description more meaningful. Below is a guideline for interpreting the new description of your TRLAXLE model number. Newly created, non-configurable axle specs and specialty axles will also adopt this new description logic. The following page gives an explanation of all the new axle description codes.

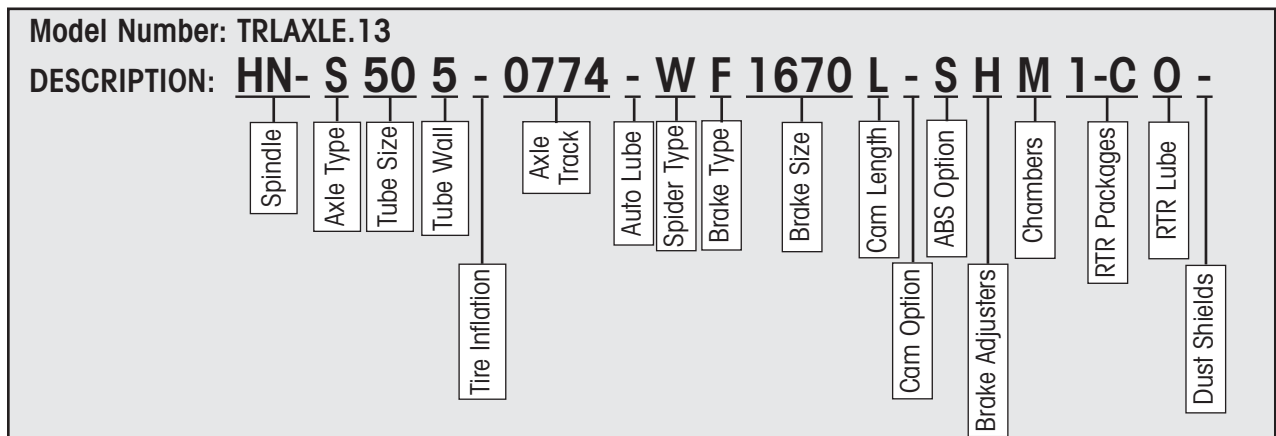



HENDRICKSON AXLE DESCRIPTION MATRIX

**Spindle**

HN - Tapered Spindle  
 HP - Parallel Spindle (Pro-Par Type)  
 P90 - HUS Unitized

**Axle Type**

S - Straight  
 U - Bent  
 C - Cambered  
 H - Half / Stub

**Tube Size**

50 - 5" Round  
 56 - 5<sup>3</sup>/<sub>4</sub>" Round

**Tube Wall**

4 - 1/2" Nominal  
 5 - 5/8" Nominal  
 H - 5/8" Nominal (Heavy Duty)  
 6 - 3/4" Nominal  
 0 - Solid Bar

**Tire Inflation**

T - TIREMAAX® or TIMS  
 P - MTIS / PSI Prepped  
 V - Axle Vent Only  
 3 - 3-Hole Prep Only  
 M - Military Set-up  
 - (Dash) - None

**Axle Track**

### - Track Length (inches) 1st 3 Digits  
 # - Track Length (1/8") 4th Digit

**Auto Lube**

L - Lube System - Fittings Installed  
 - (Dash) - None

**Spider Type**

B - Bolt-on Spider  
 F - Flange Only  
 W - Weld-on Spider  
 T - Torque Plate for Air Disc Brake  
 - (Dash) - No Spider / No S-Cams

**Brake Type**

B - B-Lock  
 S - Single Anchor Pin (SAP) Service Only  
 F - Std. Service - Dual Anchor Pin (DAP)  
 P - Pin Style  
 X - HXS / XLII - Dual Anchor Pin (DAP)  
 D - Air Disc Brake  
 - (Dash) - No Brake Shoes

**Brake Size**

1250 - 12<sup>1</sup>/<sub>4</sub>" x 5" Brakes  
 1255 - 12<sup>1</sup>/<sub>4</sub>" x 5<sup>1</sup>/<sub>2</sub>" Brakes  
 1274 - 12<sup>1</sup>/<sub>4</sub>" x 7<sup>1</sup>/<sub>2</sub>" Brakes  
 1585 - 15" x 8<sup>5</sup>/<sub>8</sub>" Brakes  
 1650 - 16<sup>1</sup>/<sub>2</sub>" x 5" Brakes  
 1670 - 16<sup>1</sup>/<sub>2</sub>" x 7" Brakes  
 1685 - 16<sup>1</sup>/<sub>2</sub>" x 8<sup>5</sup>/<sub>8</sub>" Brakes  
 1610 - 16<sup>1</sup>/<sub>2</sub>" x 10" Brakes  
 1870 - 18" x 7" Brakes  
 2080 - 20" x 8" Brakes  
 430\_ - 430mm Air Disc  
 16N\_ - 16<sup>1</sup>/<sub>2</sub>" Spider Only  
 15N\_ - 15" Spider Only  
 12N\_ - 12<sup>1</sup>/<sub>4</sub>" Spider Only  
 ---- (4 Dashes) - No Brakes

**Cam Length**

S - Std. Short Length (17<sup>5</sup>/<sub>8</sub>")  
 M - Std. Medium Length (20<sup>5</sup>/<sub>8</sub>")  
 L - Std. Long Length (23<sup>3</sup>/<sub>4</sub>")  
 X - Special Length (Non-Std.)  
 - (Dash) - No S-Cams

**Cam Option**

C - Cam Tube  
 B - RM Cartridge Bushing  
 - (Dash) - No Special Cam Options

**ABS Option**

B - ABS Mounting Bracket Only  
 S - ABS Sensor Installed  
 - (Dash) - No ABS Sensors / Brackets

**Brake Adjusters**

B - Bendix  
 G - Gunite  
 H - Haldex  
 - (Dash) - No Brake Adjusters

**Chambers**

B - Bendix  
 H - Haldex  
 M - MGM  
 K - Knorr - Air Disc Brake Only  
 - (Dash) - No Chambers

**RTR Packages**

1 - 10-stud, hub-piloted - 1st Digit  
 6 - 6-stud, hub-piloted - 1st Digit  
 8 - 8-stud, hub-piloted - 1st Digit  
 - (Dash) - No Hubs - 1st Digit

V - HVS 3-yr. - 2nd Digit  
 L - HLS 5-yr. - 2nd Digit  
 U - HUS 7-yr. - 2nd Digit  
 P - ConMet PreSet - 2nd Digit  
 - (Dash) - No RTR or 1-yr. Std. Service - 2nd Digit

- (Dash) - No Drums - 3rd Digit  
 C - Cast Drum - 3rd Digit  
 F - Fused Drum - 3rd Digit  
 315 - 3-spoke, 15" wheel - all 3 Digits  
 520 - 5-spoke, 20" wheel - all 3 Digits  
 622 - 6-spoke, 22" wheel - all 3 Digits  
 624 - 6-spoke, 24" wheel - all 3 Digits

**RTR Lube**

G - Grease  
 F - Syn. Semi-Fluid Grease  
 O - 80 / 90 Oil  
 S - SAE 50  
 - (Dash) - None

**Dust Shields**

D - Dust Shield Included  
 - (Dash) - None





## AXLE INSTALLATION

To ensure safe operation and maximum durability on parts such as brakes linings and tires, it is necessary to position and install the axle properly. It is recommended that the axle assembly be installed so the cams rotate in the same direction as the wheels (see figure 2).

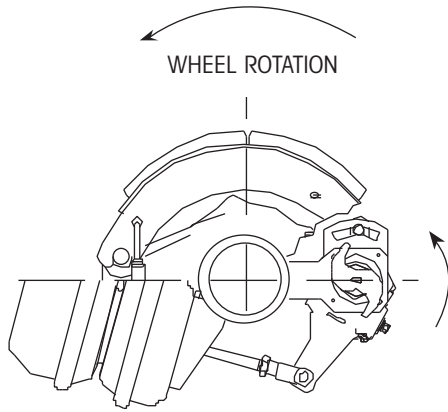

*Cam and wheels rotate in the same direction  
Figure 2*

Installation in which the camshaft rotation is opposite that of the wheel rotation could cause noisy brakes, chatter and wheel "hop". With this in mind, the axle should be ordered with the placement of air chamber and slack adjuster assemblies that will ensure the correct directional rotation of the cams when the axle is installed.

Unless otherwise specified by the customer, Hendrickson Trailer Axles are manufactured without camber. If the axle is cambered, the top dead center of the axle will have a small die mark on each end of the axle close to the inboard side of the brake spider (see figure 3).

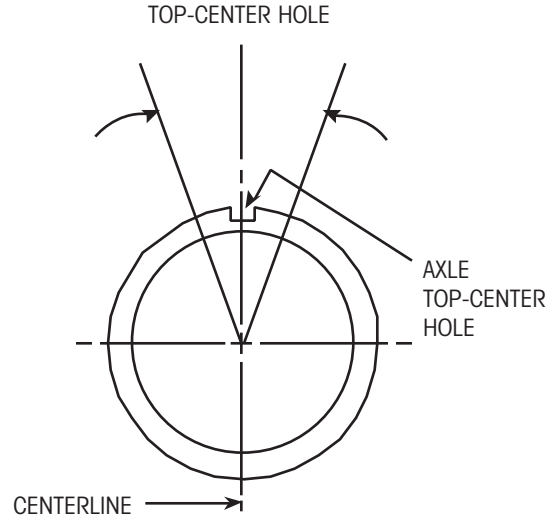

*Figure 3*

## AXLE REPAIR

**⚠ WARNING ANY AXLE FOUND WITH CRACKS SHOULD NOT BE REPAIRED, BUT REPLACED IMMEDIATELY. REPAIR WELDING CAN BE DETRIMENTAL TO THE STRUCTURAL INTEGRITY OF THE AXLE BEAM, WHERE THE BENEFIT OF THE ORIGINAL TUBE HEAT TREATMENT MAY BE NULLIFIED BY THE WELDING. AN AXLE SHAFT WEAKENED BY WELDING COULD FAIL AND CAUSE AN ACCIDENT, WHICH COULD RESULT IN SERIOUS INJURY OR DEATH.**

**NOTE:** Cambered axles must be installed with the die marks in the top center center position

It is the responsibility of the axle installer to adjust the brakes properly. See the recommended brake adjustment procedure covered in this manual.



## TRAILER AXLE ALIGNMENT

Proper preparation is a must for effective axle alignment. The vehicle, tools, equipment and work site must all be appropriate for axle alignment. The process also requires a trained technician using the correct specifications.

### I. VEHICLE PREPARATION

American Trucking Associations Technology and Maintenance Council (TMC) RP 708, *Trailer Axle Alignment*, addresses all the steps needed to make the trailer ready for alignment.

To review these:

1. Inspect the suspension and axles for any obvious damage.
2. Tighten, repair or replace, as needed, any parts that do not meet suspension or axle manufacturer criteria for serviceability.
3. Check tires for proper inflation and matching diameters.
4. Park the trailer on a smooth and level pad with the parking brakes released.

**NOTE:** After backing the trailer in, pull it forward 10 feet to a gentle stop. This will allow suspension parts to settle in a "forward running" position. Use wheel chocks to prevent injury due to accidental movement of the trailer.

5. With the brakes still released, adjust the height control valve for the proper setting and the upper coupler to the proper height by raising or lowering the landing gear legs.
6. DO NOT proceed unless the wheel bearing end play is known to be in adjustment per TMC, the bearing manufacturer and / or this manual.

### II. SPECIFICATIONS

Axle alignment specifications may be stated in inches, degrees, minutes of angle (MOA or 1/60th of a degree) or m/M. Each format can produce equivalent results. Hendrickson Trailer Axles are built to less than +/- 2.5 MOA run out at each spindle.

#### TOE-IN / TOE-OUT

Installed axles should measure no more than 8 MOA toe-in and 4 MOA toe-out.

### RECOMMENDED ALIGNMENT SPECIFICATIONS

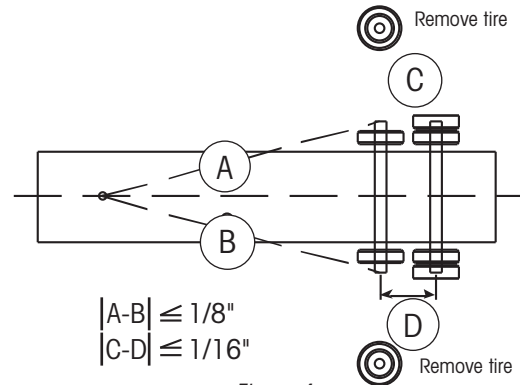

Figure 4

### ALIGNMENT

Axles should be adjusted to an alignment of no more than 5 MOA scrub with the true center of the trailer frame if it is a single axle. If the trailer has multiple axles, each axle should be adjusted to not more than 2.5 MOA scrub relative to the front (or reference) axle. (This adjustment was previously stated as a difference of not more than 1/16 inch between the right and left centers of adjacent angles).

### CAMBER

Typical trailer axles exhibit 23-29 MOA of TOTAL camber change from an off-ground free state to a fully loaded condition. Cambered axles are engineered to flex to a straight beam under load. New Hendrickson Trailer Axles may be cambered by special order with 33 MOA of positive camber. This allows the vertical axis through the tire to return to near "plumb" condition when loaded.

### III. ADJUSTMENTS

All fasteners should be loosened prior to measurements and adjustments. This reduces disturbances to the measuring equipment. All adjustments to axle alignment should be made by first moving the axle toward the rear or the trailer — past the intended point. This step assures that any free motion in the system is placed in a "draft" condition.

Repeated difficulty in adjusting the axle to the desired reading is most often due to a loose wheel bearing, badly worn suspension component or a combination.

**⚠ WARNING NEVER BEND THE AXLE, BY ANY MEANS, IN ORDER TO CORRECT ANY ALIGNMENT CONDITION. THIS COULD WEAKEN THE AXLE AND CAUSE AXLE FAILURE WHICH COULD RESULT IN SERIOUS INJURY OR DEATH.**



## GENERAL WELDING RECOMMENDATIONS

In welding suspension component parts to a Hendrickson Trailer Axle, extreme care must be exercised to obtain their correct location and to ensure the spring seated load bearing surfaces are parallel to each other. Any welding of additional attachments to the axle should be approved by the Hendrickson trailer product engineering department to maintain warranty coverage.

It is necessary when welding to avoid the high stress areas on the tube top (compression zone) and tube bottom (tension zone). All welds should be made as close to the horizontal centerline as possible. When the axle tube is subjected to the heat from welding and then rapid cooling, the material adjacent to the weld loses its desirable ductile properties and becomes brittle. If this condition exists in the high stress areas under maximum load conditions, the life of the axle will be greatly reduced and premature fatigue failure can occur. Recommended locations for the welds are shown below in figure 5.

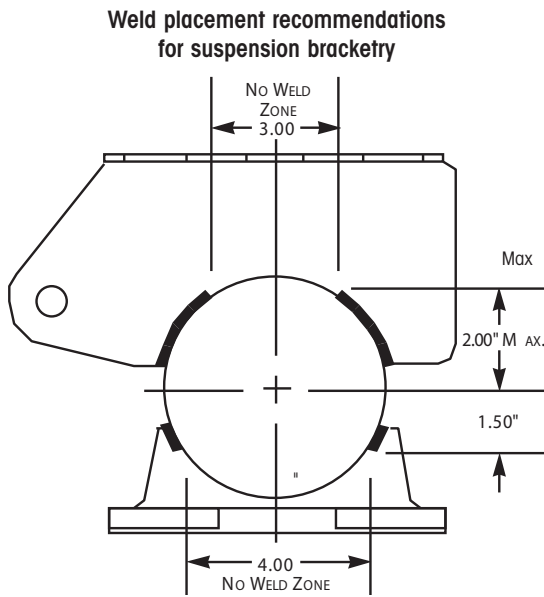

Figure 5

The welding rods should conform to American Welding Society (AWS), grade E-7018 (Oven-dried) or comparable. Recommended rod size is  $\frac{5}{32}$  inch at voltage and amperage recommended by the electrode manufacturer. For maximum strength, a three-pass weld should be used.

The arc should not be broken at the end of each pass and the corners should be wrapped. The electrode should be backed up to fill in the filler crater at the end of each pass. Thoroughly clean the weld between each pass.

**⚠ CAUTION** Do not bring axles in from non-heated storage and weld while cold.

**⚠ CAUTION** To provide optimum suspension-to-tube welds, preheating is recommended. Preheating will minimize loss of ductile properties in the weld area by slowing the rate of cooling, thus reducing the formation of an untempered martensitic grain structure adjacent to the weld. Martensite, a brittle grain structure, is formed by the rapid cooling of the metal surrounding the weld area. Preheat the suspension seat weld area to 500 to 600° Fahrenheit with a rosebud prior to welding. Preheat temperature should be verified with a temperature sensitive crayon or other appropriate means.

**⚠ CAUTION** Do not "test the arc" on the axle beam.

### HARDWARE FIT

Avoid excessive welding. Fit the seat / hardware as close as possible to the axle. The gap should not exceed  $\frac{1}{8}$  inch see Figure 6.

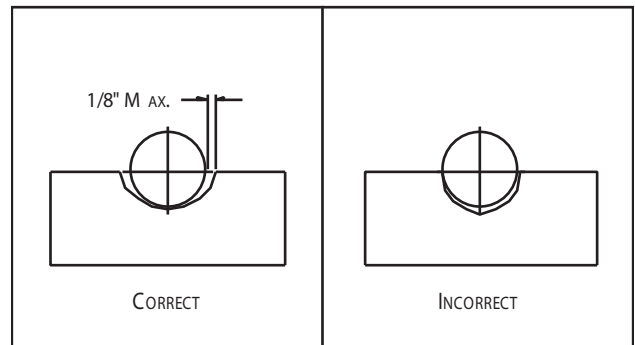

Figure 6



## WELDING METHODS

Table 1 lists four methods that may be used to weld hardware to trailer axles. The weld tensile strength must be 70,000 psi per AWS specifications.

| TABLE 1   |                              |              |
|---|------------------------------|--------------|
| METHOD FOR WELDING CARBON AND LOW ALLOY STEELS                                | AWS ELECTRODE CLASSIFICATION | AWS SPEC     |
| Shielded Metal Arc<br>(stick electrodes)                                      | E70XX                        | A5.1<br>A5.5 |
| Gas Metal Arc<br>(MIG, solid wire feed)                                       | ER70S-X                      | A5.18        |
| Gas Tungsten Arc<br>(TIG) has non-consumable electrode (use stick electrodes) | ER70-X                       | A5.18        |
| Flux Cored Arc<br>(self shielded wire)  | E70T-X                       | A5.20        |

## WELDING HARDWARE TO AXLE

- ⚠ CAUTION**
- The axle installer should obtain and read a copy of the suspension manufacturer's installation instructions.
  - Only use operators certified by AWS.
  - The axle and its mating bracket must be at 60 degrees minimum and free of moisture, dirt, scale, paint and grease. Do not bring in axles from non-heated storage and weld while cold.
  - Prevent bearing damage. When grounding welding equipment to the axle, prevent current from passing through the wheel bearings.

## TACK WELDING BRACKET TO AXLE:

**NOTE:** Do not place tack welds at what will be the ends of the final weld. Tack weld all brackets onto axle before fusing these tack welds into final welds. Thoroughly clean the slag from the tack welds before applying the final welds (see figure 7).

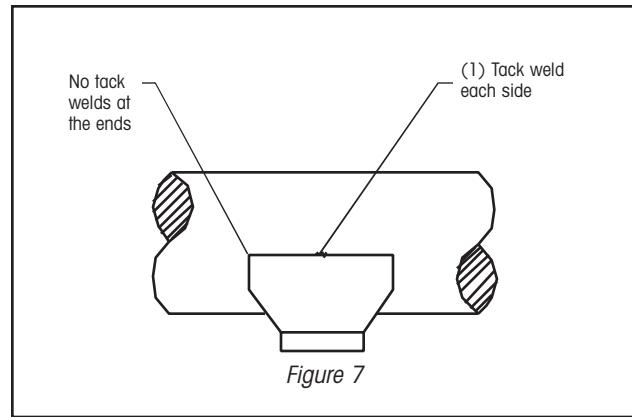

**NOTE:** For maximum strength, a three-pass weld should be used. All final welds should be made in one continuous pass. The arc should not be broken at the end of each pass and the corners should be wrapped.

**NOTE:** TO PREVENT AXLE DISTORTION:

- Alternate welds between the front and rear of the bracket.
- Alternate welds between the roadside bracket and curbside bracket.

This welding recommendation pertains to all Hendrickson tubular axles. Unapproved variation from the procedures listed will void the axle warranty and could result in an unsafe weld. In the case of an uncertain circumstance, the Hendrickson Trailer Products Engineering Department should be contacted at 1-800-RIDEAIR (743-3247).



## WHEEL BEARINGS

### OIL LUBRICATED WHEEL ENDS

Oil should be changed at least every 100,000 miles or once a year and whenever the seals or brakes are replaced. Oil level should be inspected every 1,000 miles. Always allow a few minutes after adding oil or vehicle operation for the oil to settle, when establishing the required oil level.

### SUGGESTED OIL PROPERTIES

Petroleum based or synthetic oils that meet or exceed military specification MIL-L-2105D and American Petroleum Institute (API) service classification GL-1 through GL-5 are the minimum requirements for use in Hendrickson Trailer Axles.

The table below indicates which SAE viscosities are recommended for various temperature ranges the vehicle will encounter.

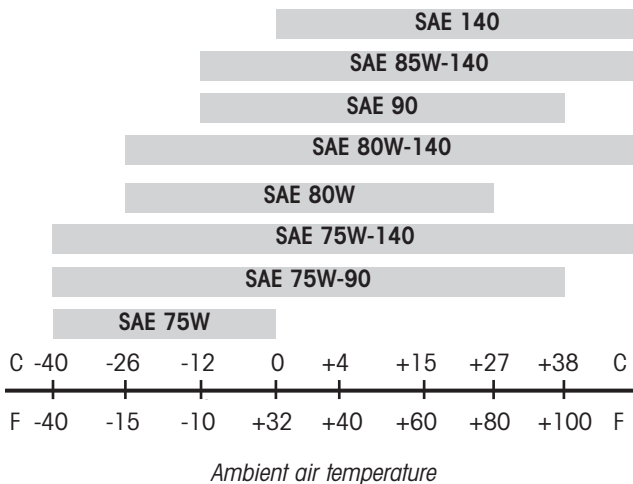

**⚠ WARNING DO NOT MIX MOTOR OIL WITH EP GEAR OIL DUE TO POSSIBLE COMPATIBILITY PROBLEMS.**

**⚠ WARNING FAILURE TO CORRECTLY LUBRICATE BEARINGS AND TO MAINTAIN PROPER LUBRICATION COULD CAUSE BEARING AND AXLE SPINDLE DAMAGE, WHICH COULD RESULT IN THE WHEEL LOCKING UP OR COMING OFF DURING VEHICLE OPERATION.**

### GREASE LUBRICATED WHEEL ENDS

Grease should be replaced if contaminated or if the hub is removed from the spindle. For normal service, grease should be replaced annually or at 100,000 mile intervals. For severe or off-highway service, grease should be replaced semi-annually or at 30,000 mile intervals. Bearings should be packed by machine or by hand methods to ensure grease is forced into the cavities between the rollers, cone and cage of the bearings. The wheel and hub cap should be filled with grease when reassembling.

### SUGGESTED GREASE PROPERTIES

The table below recommends the NLGI-2 grade of grease under normal loading and operating speeds of 100 -1000 rpm. For heavy loads and low speeds, the advice of a lubrication engineer should be obtained.

| GREASE GUIDE                     |                   |                     |
|----------------------------------|-------------------|---------------------|
| SOAP BASED GREASE TYPE           | NLGI GREASE GRADE | NOTE                |
| Calcium Complex                  | #1                | Use in Extreme Cold |
| Lithium Complex                  | #2                | Normally Preferred  |
| SEMI FLUID SYNTHETIC GREASE TYPE | NLGI GREASE GRADE | NOTE                |
| Mobilith 007 or equivalent       | #00               | Normally Preferred  |

**⚠ WARNING DO NOT MIX LITHIUM, CALCIUM, SODIUM OR BARIUM COMPLEX GREASES DUE TO POSSIBLE COMPATIBILITY PROBLEMS. WHEN CHANGING FROM ONE TYPE OF GREASE TO ANOTHER, IT IS NECESSARY TO ENSURE THAT ALL THE OLD GREASE HAS BEEN REMOVED.**



## WHEEL BEARING ADJUSTMENT PROCEDURE

### DOUBLE NUT ARRANGEMENT

1. Prior to installing any wheel-end fasteners, make sure the spindle area is free of dirt and debris. As well, make sure all nuts and washers are free of dirt. Clean mating surfaces are important for proper wheel-end assembly.
2. After properly installing the bearing cones and wheel-end seal onto the spindle and sliding the wheel end onto the spindle, tighten the inner spindle nut with a torque wrench to 150-200 ft. lbs. to set the bearings and wheel end.

**⚠ CAUTION** Do not use an air impact wrench to tighten this nut.

3. Loosen this inner nut to allow the brake drum to rotate freely. Backing off one (1) full turn is recommended.
4. Retighten the inner spindle nut to 50 ft. lbs. by hand using a torque wrench to position the bearings for final adjustment.

**⚠ CAUTION** Do not use an air impact wrench to tighten this nut.

5. Back the inner spindled nut off 1/4 turn.
6. Install the retaining fastener or fasteners onto the spindle according to the fastener used. If washers are used, be sure they are facing in the right direction and are clean. Make sure any washers with dowels fit properly into the mating holes.

7. Install the outer spindle nut. Using a torque wrench, tighten this nut to 300-400 ft. lbs. Resulting end play should be .001 to .005 inch.

**NOTE:** If end play is not .001 to .005 inch, disassemble and repeat this procedure

**⚠ WARNING** FAILURE TO TORQUE THE OUTER LOCK NUT PROPERLY COULD CAUSE THE WHEEL TO COME OFF DURING VEHICLE OPERATION, WHICH COULD RESULT IN PROPERTY DAMAGE, SERIOUS INJURY OR DEATH.

**⚠ WARNING** IF AN EXTERNAL TANG OR SETSCREW TYPE LOCK WASHER IS USED, IT IS IMPORTANT TO REMEMBER TO BEND THE TABS OVER THE OUTER LOCK NUT, OR TO INSTALL THE SET SCREWS IN THE LOCK WASHER AFTER THE OUTER NUT HAS BEEN TORQUED. FAILURE TO FOLLOW THIS PROCEDURE COULD RESULT IN PROPERTY DAMAGE, SERIOUS INJURY OR DEATH.

Periodic inspection and regular replacement of lubricant is important to obtain maximum bearing life. Always inspect bearings for damage prior to installation. When installing wheel bearings, it is important to ensure both the inside of the wheel hub and bearings are clean. Hendrickson recommends that seals be replaced when wheels are removed. Extreme care should be taken when reinstalling wheels to prevent damage to the seals.

### SPECIFICATIONS

| AXLE MODEL | LOCATION    | SPICER BEARING CUP NUMBER | SPICER BEARING CONE NUMBER | INDUSTRY STD. CUP NUMBER | INDUSTRY STD. CUP NUMBER | WIDTH  | OUTSIDE DIAMETER | INSIDE BORE |
|------------|-------------|---------------------------|----------------------------|--------------------------|--------------------------|--------|------------------|-------------|
| D22        | Inner       | M10HA102                  | M10HB100                   | HM218210                 | HM218248                 | 1.575" | 5.787"           | 3.542"      |
| D22        | Outer       | M10HA103                  | M10HB101                   | HM212011                 | HM212049                 | 1.500" | 4.813"           | 2.625"      |
| P22        | Inner/Outer | M10HA116                  | M10HB119                   | HM518410                 | HM518445                 | 1.563" | 6.00"            | 3.501"      |





### RECOMMENDED BRAKE ADJUSTMENT PROCEDURE

**⚠ CAUTION** Failure to properly adjust brakes could cause reduced braking performance.

1. Grease cam bracket and spider fittings prior to brake shoe installation.

**⚠ WARNING** CARE MUST BE EXERCISED TO PREVENT GREASE SPACING FROM COMING IN CONTACT WITH BRAKE LININGS WHICH COULD CAUSE A REDUCTION IN BRAKING PERFORMANCE. REDUCED BRAKING PERFORMANCE COULD CAUSE AN ACCIDENT RESULTING IN SERIOUS INJURY OR DEATH.

2. Adjust the brake adjuster until the brake lining comes into contact with the brake drum.

A. For green brakes\* there should be a slight amount of wheel drag at initial adjustment to compensate for any lining irregularities (high spots, etc)

\*A "green brake" is an unground, unburnished brake. There is a break-in period where the lining will seat into a normal contact pattern with the drum

B. For burnished or broken-in brakes, back off the slack adjuster to achieve .010 inch clearance between drum and shoe

3. Apply brakes using normal truck operating pressure (average line pressure should be 90 psi).

**⚠ WARNING** USE OF AIR PRESSURE EXCESS OF 130 PSI COULD RESULT IN FAILURE OF THE AIR CHAMBER OR SPRING BRAKE CHAMBER, WHICH COULD RESULT IN SERIOUS INJURY OR DEATH.

A. Check the amount of push rod travel. Maximum should not exceed 2 1/2 inches for Type 30 long-stroke chambers, 2 inches for Type 30 chambers and 1 3/4 inches for Type 24 chambers

a. Optimum pushrod travel on a green brake should be under 2 inches

b. Optimum pushrod travel on a burnished or broken-in brake should be under 1 3/4 inches

- B. Check the angle between the brake adjuster and pushrod. With the brakes applied, the angle should be 90 degrees +/- 5 degrees

**⚠ CAUTION** When automatic brake adjusters are used, it is necessary to follow the installation and adjustment procedure recommended by the automatic brake adjuster manufacturer. Failure to follow the recommended procedure could result in improper operation of the automatic slack adjuster, resulting in reduced brake performance or premature lining wear.

C. For burnished brakes, apply pressure to brakes and check for lining to drum contact. Using a .010 inch feeler gauge, the lining to drum contact should range from 60 to 100 percent during brake application

D. Check to ensure the lining is inside the drum during application. More than .060 inch protruding out of the drum is not recommended

4. Rapidly release air pressure from the brakes and confirm that all brakes quickly release to the normal relaxed position

**⚠ WARNING** • BRAKE LININGS CONTAIN NON ASBESTOS FIBERS

• BREATHING BRAKE DUST MAY BE HAZARDOUS TO YOUR HEALTH AND MAY CAUSE SERIOUS RESPIRATORY OR OTHER BODILY HARM

• AVOID CREATING DUST

• DO NOT REMOVE BRAKE DRUM WITHOUT PROPER PROTECTIVE EQUIPMENT.



- DO NOT WORK ON LININGS WITHOUT PROPER PROTECTIVE EQUIPMENT

- DO NOT REPLACE LININGS WITHOUT PROPER PROTECTIVE EQUIPMENT

- DO NOT ATTEMPT TO SAND, GRIND, CHISEL, FILE, HAMMER OR ALTER BRAKE LININGS IN ANY MANNER WITHOUT PROPER PROTECTIVE EQUIPMENT

- FOLLOW O.S.H.A. STANDARDS FOR PROPER PROTECTIVE DEVICES TO BE USED WHEN WORKING WITH BRAKE MATERIALS

**⚠ WARNING** IT IS CRITICAL THAT ANY BRAKE DRUM REACHING MAXIMUM WEAR DIAMETER, AS CAST ON DRUM, BY TURNING, GRINDING AND / OR WEARING BE CONSIDERED UNSAFE AND IMMEDIATELY REPLACED. IN ORDER TO AVOID SERIOUS INJURY OR DEATH, ANY BRAKE DRUM EXCEEDING THIS DIMENSION IS CONSIDERED A SAFETY HAZARD. IF IN DOUBT, CONTACT THE BRAKE DRUM MANUFACTURER.

## BRAKE DISASSEMBLY / ASSEMBLY

### BRAKE DISASSEMBLY

1. Release brakes and back off slack adjuster.
2. Remove slack adjuster lock ring and slack adjuster.
3. Remove brake drum.
4. Remove anchor pins and brake shoes.

**⚠ CAUTION** Excessive pounding on anchor pins or cam roller pins to remove or install them can damage the pins and cause misalignment of the brake spiders and brake shoes. The use of a soft hammer or brass drift is recommended to remove or install the anchor pins.

5. Remove brake return springs.
6. Remove camshaft lock ring, spacer washer and cam shaft.
7. Remove cam roller and shaft (in case of the cast shoe, remove roller shaft set screw and roller assembly) and anchor pin bushing from shoes.
8. Remove anchor pin bushings, camshaft bushing and seals from spider.

### BRAKE ASSEMBLY

1. Install new anchor pin bushings, camshaft bushing and camshaft seals into the spider.

**⚠ WARNING** WHEN INSTALLING CAMSHAFT SEALS, THE SEAL ON THE SLACK ADJUSTER SIDE SHOULD BE INSTALLED WITH SEAL FACING INTO SPIDER. THIS ALLOWS GREASE TO PURGE OUTSIDE THE BRAKE ASSEMBLY WHEN GREASING THE CAMSHAFT BUSHING. FAILURE TO FOLLOW THIS PROCEDURE COULD CAUSE GREASE TO COME INTO CONTACT WITH BRAKE LININGS, CAUSING BRAKE FAILURE.

2. Install cam roller assemblies onto the brake shoes.
3. Install the camshaft into the spider; Install spacer washer and lock ring on cam before sliding the cam through the camshaft support bracket; Install the slack adjuster and the lock ring.





**⚠ WARNING** WHEN REASSEMBLING BRAKES, HENDRICKSON RECOMMENDS THAT THE BRAKE RETURN SPRINGS BE REPLACED WITH NEW SPRINGS TO ASSURE PROPER OPERATION OF THE BRAKE.

4. Install the brake return springs on the brake shoes.
5. Position brake shoes on the spider and insert the anchor pins.
6. If air brake chambers are replaced, the correct mounting holes must be used to correspond to brake adjuster length. (see figure 8)

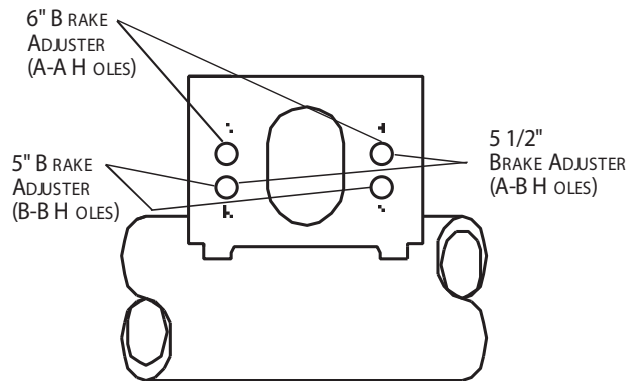

Figure 8

7. Connect slack adjuster to brake chamber pushrod
8. Adjust brakes as outlined in brake adjustment procedures

**NOTE:** To ensure brakes meet F.M.V.S.S. 121 performance requirements, Hendrickson recommends that only original equipment brake components be used.

Any questions or comments on the above procedure should be directed to the Hendrickson trailer engineering department.

WELDING ABS WHEEL SPEED SENSOR BLOCKS

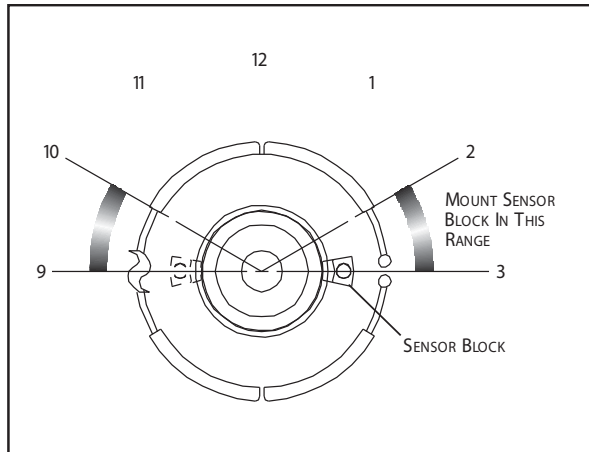

Figure 9

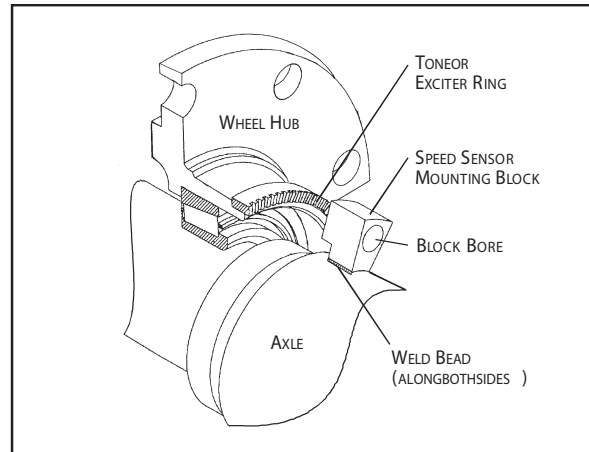

Figure 10

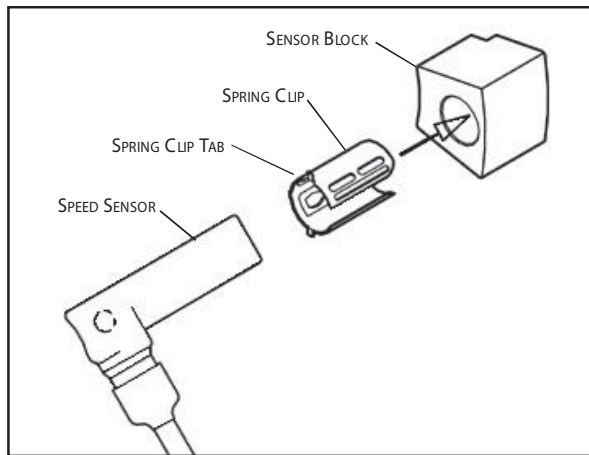

Figure 11

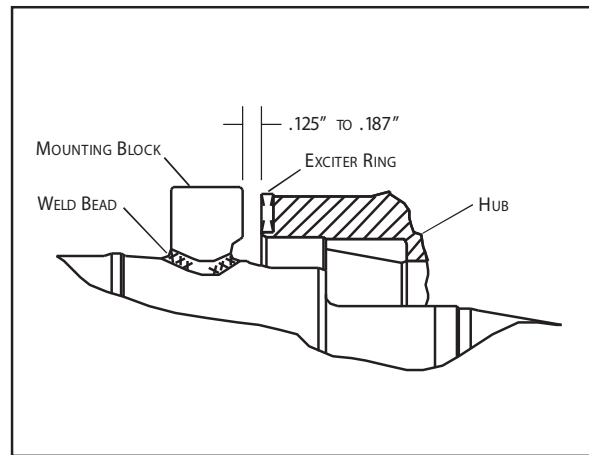

Figure 12

Correct installation of the speed sensor blocks is extremely important for proper operation of the anti-lock system. Use electric welding equipment only to install the blocks.

1. Properly support the trailer axle using jack stands, be sure to provide proper clearance to be able to weld the sensor block on the axle near the tone (exciter) ring.
2. With the hub in place, locate the sensor mounting block at the 9 or 3 o'clock position on the axle spindle to lessen the effect from axle flexure due to loading (see figure 9) manually hold the sensor block in place and scribe its location on the axle spindle (see Figures 10 and 12).

**NOTE:** The distance of the sensor block from the face of the tone ring "teeth" must be between .125 inch to .187 inch (see figure 12).

3. Remove the hub and bearing assembly and brake assembly from the axle spindle. Clean all oil or grease from the axle spindle.
4. Install the sensor block on the fixture tool and attach the fixture tool to the axle spindle.
5. Adjust the position of the fixture tool as necessary to align the sensor block to the scribed position in step 2 and tighten in place.
6. Weld the sensor block to the spindle axle; weld along both sides of the block (see Figure 10).
7. Remove the fixture tool and let the sensor block cool after cool down, install the sensor spring clip and sensor as illustrated in Figure 11.



## TORQUE SPECIFICATIONS

| FASTENER SPECIFICATIONS |                        |                      |
|-------------------------|------------------------|----------------------|
| PART NAME               | SIZE & THREAD          | TORQUE               |
| Spindle Outer Nut       | 2 5/8 - 16UN           | 250 - 400 ft. - lbs. |
| Cam Brackets            | 5/16 - 18 Self-tapping | 175 - 225 in. - lbs. |
| Air Chamber             | 5/8 - 11 UNC           | 100 - 115 ft. - lbs. |
| Mounting Bolts          |                        |                      |
| Dust Shield             | Self-tapping           | 180-200 in. - lbs.   |
| Mounting                |                        |                      |
| Brake Lining            | Brass Screw            | 100-150 in. - lbs.   |
| To Table                | 3/8 - 24UNF            |                      |
| Hub Cap to Hub          | 1/14 - 20UNC           | 96-144 ft. - lbs.    |
|                         | 5/16 - 18 UNC          | 144-216 in. - lbs.   |
| Wheel Stud              | 3/4 - 16UNF            | 175-200 ft. - lbs.   |
| Backnut                 | 7/8 - 14 UNF           | 180-250 ft. - lbs.   |
|                         | 1 - 14 UNF             | 200-300 ft. - lbs.   |
| Haldex ABA              | 7/16 - 14 UN           | 40-50 ft. - lbs.     |
| Control Arm Nut         |                        |                      |

## SUGGESTED PREVENTATIVE MAINTENANCE

### EVERY 1,000 MILES:

- Check oil level in wheel hub and inspect wheel for leaks

### 15,000 MILES OR MINIMUM OF TWICE A YEAR:

- Check brake adjustment
- Repack wheel bearings (grease application)

### 25,000 TO 30,000 MILES:

- Check lining wear and estimate replacement time; replace with new shoes or reline when thickness of lining is 1/4 inch at thinnest point, or 1/16 inch about rivet or bolt head, and replace any cracked, broken or oil-soaked linings immediately
- Inspect camshaft, camshaft spider bushing and camshaft support bracket bushing for any signs of wear
- Lubricate camshaft bushings and brake adjusters
- Inspect brake drums for heat checks, grooves, hot spots, glazing, cracks and out-of-round

### 100,000 MILES, ONCE A YEAR OR AT BRAKE RELINE:

- Replace wheel bearing lubricating oil (if applicable)
- Check brake air chambers and slack adjusters
- Inspect brake rollers, roller shafts, anchor pins and bushings and replace if necessary
- Lubricate camshaft bushings and brake adjusters
- Check shoes for bent shoe ribs, cracks in shoe table welds or ribs, and elongated rivet holes. Replace shoes if any of these conditions exist

---

[www.hendrickson-intl.com](http://www.hendrickson-intl.com)



Trailer Suspension Systems  
250 Chrysler Drive, Unit #3  
Brampton, ON Canada L6S 6B6  
905.789.1030  
Fax 905.789.1033

Trailer Suspension Systems 866.RIDEAIR (743.3247)  
2070 Industrial Place SE 330.489.0045  
Canton, OH 44707-2641 USA Fax 800.696.4416

Trailer Suspension Systems  
Av. Industria Automotriz #200  
Parque Industrial Sliva Aeropuerto  
Apodaca, N.L., México C.P. 66600  
(52) 81 8288 1300  
Fax (52) 81 8288 1301