



# PARTS LIST

PRIMAAX® & PRIMAAX EX  
Kenworth Heavy Duty Suspension

LIT NO: 97114-098

DATE: March 2024

REVISION: J





## TABLE OF CONTENTS

<b>INTRODUCTION</b> .....	3
<b>SUSPENSION IDENTIFICATION</b> .....	4
PRIMAAX® GENERATION IDENTIFICATION.....	4
PRIMAAX SUSPENSION RATING IDENTIFICATION.....	4
RIDE HEIGHT.....	5
<b>SUSPENSION MEASUREMENTS</b> .....	5
BEAM WIDTH & CROSS TUBE MEASUREMENT.....	5
FRAME WIDTH MEASUREMENT.....	6
<b>QUIK-ALIGN PIVOT SELECTION</b> .....	6
PIVOT FASTENER IDENTIFICATION.....	6
PIVOT BUSH IDENTIFICATION.....	6
PIVOT COLLAR IDENTIFICATION.....	6
PIVOT HARDWARE KITS.....	7
<b>COMPONENT SELECTION GUIDES</b> .....	8
PRIMAAX® 230/460 & PRIMAAX EX 232/462/692 TORQUE RODS & AXLE PADS.....	8
Longitudinal Torque Rod.....	8
Axle Pad Selection.....	9
PRIMAAX® EX 262/522/782 TORQUE RODS & AXLE PADS.....	10
<b>230/460 PRIMAAX® GEN II</b> .....	12
<b>232/462/692 PRIMAAX® EX</b> .....	14
<b>262/522/782 PRIMAAX® EX</b> .....	16
<b>HEIGHT CONTROL VALVE</b> .....	19
<b>SPECIAL TOOLS</b> .....	20

### Document Interactivity

The interactive **Table of Contents** allows users to quickly navigate to the appropriate page with a single mouse click. The **INDEX** button at the bottom of each page returns you to the **Table of Contents**. Other links within the document are identified by black underlined text, whereas links to external websites are identified by blue underlined text.



## INTRODUCTION

The purpose of this parts list is to document service repair parts and special tools available for the PRIMAAX® 230 and 460 and the PRIMAAX Extreme (EX) 232, 262, 462, 522, 692 and 782 suspension systems supplied by Hendrickson Asia Pacific and installed at OEM level by Kenworth.

PRIMAAX EX is a severe-duty vocational air suspension that uses advanced weight-saving suspension technology to meet the rigorous demands of vocational, severe-service, and heavy-haul applications. This system features a robust structural design with optimized suspension geometry for exceptional stability, handling and ride.

**NOTE:** All quantities listed within this parts list are as applicable for a single axle.

### Application Table PRIMAAX (Past Production Suspensions)

Category	PRIMAAX® 230	PRIMAAX 460
Capacity	10,500 kg	18,000 kg
Axle Configuration	Single	Tandem
GCM Approval	Contact Vehicle OEM	
Engine Torque Restrictions	No Limit	No Limit

### Application Table PRIMAAX EX (Current Production Suspensions)

Category	232	262	462	522	692	782
Capacity	10,500 kg	11,500 kg	21,000 kg	23,500 kg	31,000 kg	35,000 kg
Axle Configuration	Single	Single	Tandem	Tandem	Tridem	Tridem
GCM Approval	Contact Vehicle OEM					
Axle Travel	150 mm					
Ground Clearance	270 mm					
Lift Axles	Approved					
Engine Torque Restrictions	No Limit					

#### Abbreviations

Abbreviations used in this document include the following terms:

- AR – As Required
- EX – Extreme
- Exc – Except
- NLA – No Longer Available
- NSS – Not Serviced Separately



## SUSPENSION IDENTIFICATION

Please review the notes below to assist with the identification of the PRIMAAX® or PRIMAAX EX model fitted. Production of the upgraded PRIMAAX EX suspension began in late 2009.

### PRIMAAX® GENERATION IDENTIFICATION

PRIMAAX Gen II (Up to November 2009)

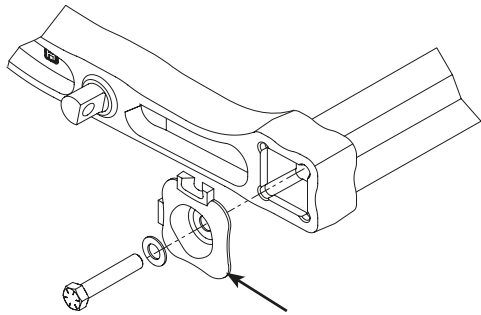

PRIMAAX Gen II detachable end cap

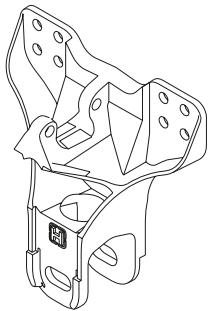

PRIMAAX Gen II frame hanger

PRIMAAX EX

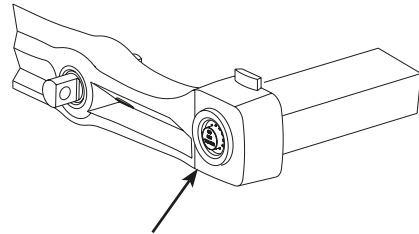

PRIMAAX EX integrated end cap

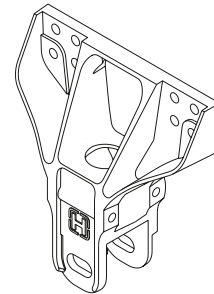

PRIMAAX EX frame hanger \*

PRIMAAX EX can be distinguished from earlier suspension generations by the enhanced integrated end cap, which does not need regular retorquing. It also has a hanger that is visibly different.

\* **NOTE:** Some vehicles fitted with PRIMAAX EX also use a fabricated hanger.

### PRIMAAX SUSPENSION RATING IDENTIFICATION

PRIMAAX 230/460 and PRIMAAX EX 232/462/692 have 108 mm (4-1/4") between the U-bolts.

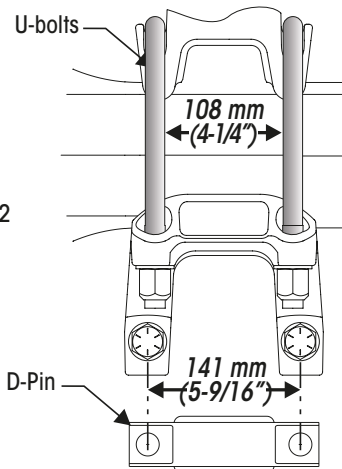

PRIMAAX EX 522 has 127 mm (5") between the U-bolts.

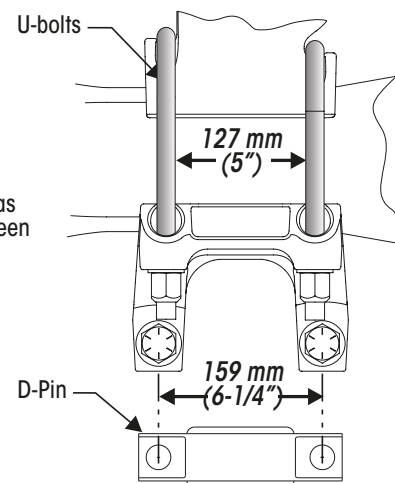

Standard PRIMAAX and PRIMAAX EX suspension U-bolts are 108 mm (4-1/4") apart and the D-Pin holes are 141 mm (5-9/16") from centre to centre. Higher capacity PRIMAAX EX 262/522/782 suspensions have 127 mm (5") between the U-bolts and D-Pin holes are 159 mm (6-1/4") from centre to centre.

## RIDE HEIGHT

The most common ride height for PRIMAAX and PRIMAAX EX suspension is 10-inch (254 mm). However, an 8-inch (203 mm) ride height option is also available. The 8-inch ride height suspension uses a spacer between the axle and the suspension beam, along with unique U-bolts. Refer to the diagrams below.

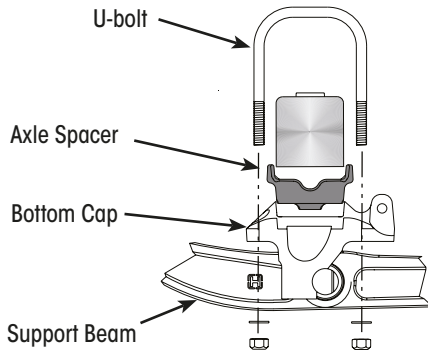

*8-Inch (203 mm) Ride Height with Spacer*

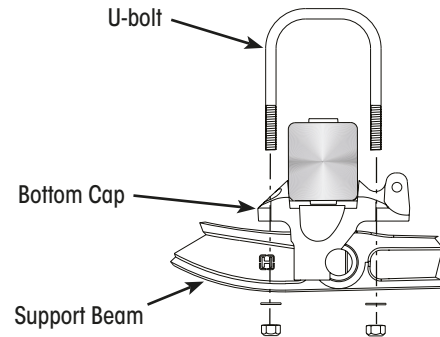

*10-Inch (254 mm) Ride Height without Spacer*

## SUSPENSION MEASUREMENTS

Kenworth vehicles normally have a frame width, including spacer, of 864 mm. This then corresponds to a PRIMAAX EX beam width of 1016 mm. However, if there is any doubt about the suitability of parts the following measurements may be taken.

### BEAM WIDTH & CROSS TUBE MEASUREMENT

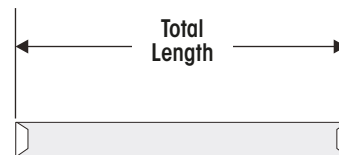
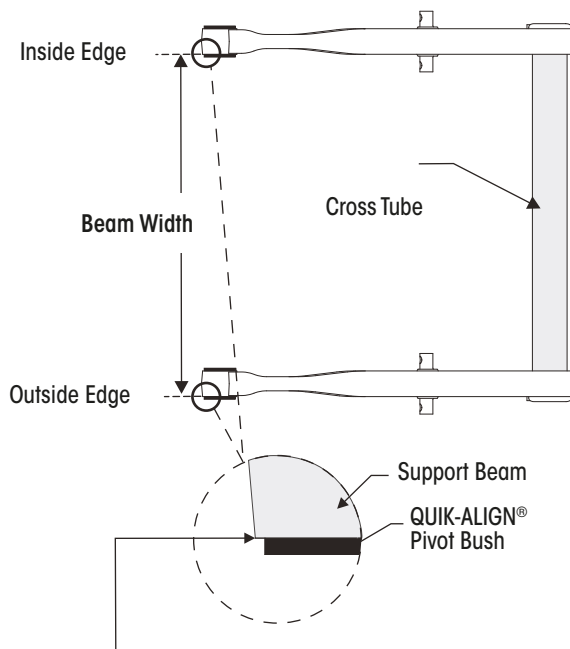

Cross tube length can only be accurately measured after it has been disassembled from the U-beam. However, disassembly is not recommended unless the complete beam is being replaced and there is doubt about which beam to purchase.

Beam width can be checked while still installed on the vehicle by measuring from the inside edge of the support beam to outside edge of the support beam.

Beam Width	Frame Width (Refer Box Below)	Cross Tube Length
1016 mm	864 mm	1053 mm



## FRAME WIDTH MEASUREMENT

Measurement of the frame width dimension is from outside of chassis to outside of chassis. If the vehicle is fitted with hanger spacer plates (between chassis and frame hanger) be sure to include this thickness in your total measurement.

For example:

- Frame 852 mm + Spacer plate (2 x 6 mm) = 864mm.

**NOTE:** Measurements must be taken at both the front and rear hangers.

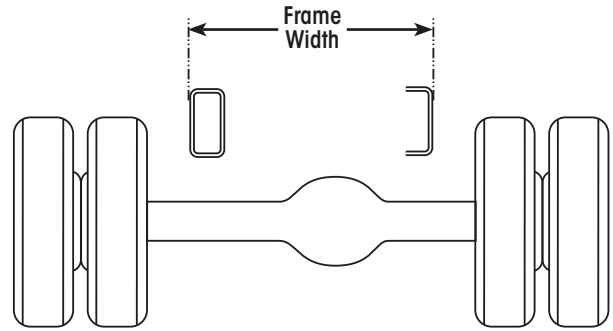

## QUIK-ALIGN PIVOT SELECTION

### PIVOT FASTENER IDENTIFICATION

PRIMAAX® and PRIMAAX EX use two distinct QUIK-ALIGN® pivot connection hardware sizes. Larger 1¼" was used between 2011 and late 2017. However, it is also possible for trucks built outside these dates to use this hardware and for the standard 1" to be fitted within that date range. Therefore, it is important to physically measure the pivot connection hardware before ordering any related parts.

Both fasteners are suitable for severe duty vehicle operation. The 1" fasteners require a torque of 750 Nm while the 1¼" requires a massive 1760 Nm. If the vehicle uses 1¼" pivot bolts and the higher torque is difficult to achieve, then it is recommended the fasteners and collars be replaced with the smaller bolt. A 1" bolt tightened to the correct torque is more dependable than a 1¼" that is not fully torqued.

Standard QUIK-ALIGN pivot bolts have a 1"–14 UNF thread. They can be identified by the 38 mm (1-1/2") bolt head. Torque specification is 750 Nm.



Larger QUIK-ALIGN pivot bolts have a 1-1/4"–12 UNF thread. They can be identified by the 47 mm (1-7/8") bolt head. Torque specification is 1760 Nm.



### PIVOT BUSH IDENTIFICATION

A severe-duty pivot bush kit is available as an aftermarket service part. It features a modified rubber design with separate snap on thrust washers. The design enhances bush life under severe braking, acceleration and articulation events. Kits are available for both bolt sizes.

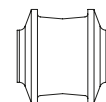

Heavy-duty standard production one-piece pivot bush.

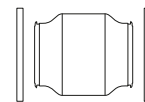

Severe-duty pivot three-piece service kit. Bush uses snap tabs to retain thrust washers during U-beam installation.

### PIVOT COLLAR IDENTIFICATION

Pivot collars vary depending on bolt size. Pivot collars for the 1" bolts have a prominent locating sleeve while the 1¼" bolt collars do not.



Collar for 1" bolt with sleeve



Collar for 1¼" bolt without sleeve

### Bush Sleeve Diameter 1¼" Bolt

The recommended pivot bush for the 1¼" bolt is the severe-duty three-piece bush kit. It is possible to use the standard production heavy-duty bush with the 1¼" bolt but the bush needs to be checked before assembly. Push the 1¼" bolt into the installed bush to ensure the shank can pass through completely without catching on the sleeve. If not, ream the pivot bush inner sleeve to 31.75 mm (1¼").

## PIVOT HARDWARE KITS

### Fastener Kits

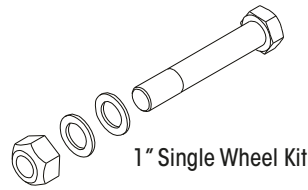

Part Number	Description	Qty	Notes
60632-018	1" Fastener Kit – Single Wheel	2	1" – 14 UNF. Includes bolt, nut & washers.

### Fastener & Collar Kits

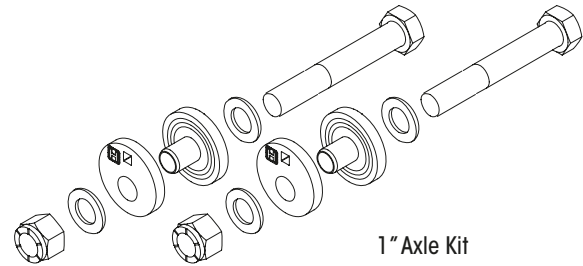
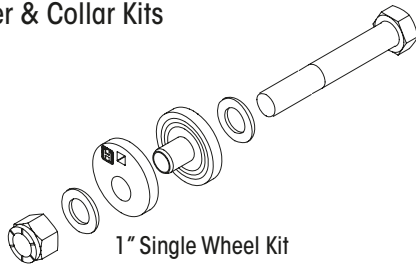

Part Number	Description	Qty	Notes
60632-019	1" QUIK-ALIGN Fastener & Collar Kit – Single Wheel	2	1" – 14 UNF. Includes collars, bolt, nut & washers.
60632-021	1" QUIK-ALIGN Fastener & Collar Kit – Axle Set	1	1" – 14 UNF. Includes collars, bolts, nuts & washers.
60632-015	1 ¼" QUIK-ALIGN Fastener & Collar Kit – Axle Set Not Illustrated	1	1 ¼" – 12 UNF. Includes collars, bolts, nuts & washers.

### Pivot Bush & Fastener Kits

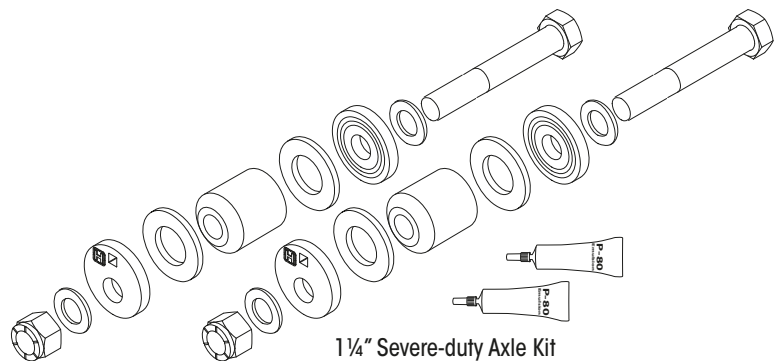
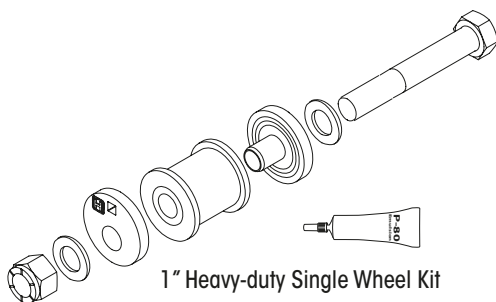

Part Number	Description	Qty	Notes
60961-720	1" Heavy-duty Pivot Bush Kit – Single Wheel	2	1" – 14 UNF. Includes bush, P-80 lubricant, collars, bolt, nut & washers.
60632-020	1" Heavy-duty Pivot Bush Kit – Axle Set. Not Illustrated	1	1" – 14 UNF. Includes bushes, P-80 lubricant, collars, bolts, nuts & washers.
60632-043	1" Severe-duty Pivot Bush Kit – Axle Set Not Illustrated	1	1" – 14 UNF. Includes severe-duty bushes, thrust washers, P-80 lubricant, 1" collars, bolts, nuts & washers.
60632-033	1 ¼" Severe-duty Pivot Bush Kit – Axle Set	1	1 ¼" – 12 UNF. Includes severe-duty bushes, thrust washers, P-80 lubricant, 1 ¼" collars, bolts, nuts & washers.



## COMPONENT SELECTION GUIDES

### PRIMAAX® 230/460 & PRIMAAX EX 232/462/692 TORQUE RODS & AXLE PADS

#### Longitudinal Torque Rod

##### Drum Brake

Torque rod and top pad assemblies are available. Refer table next page.

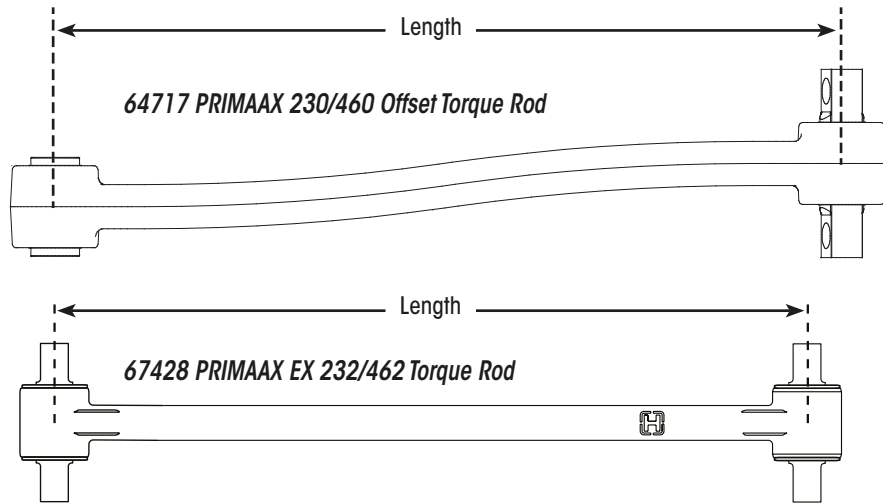
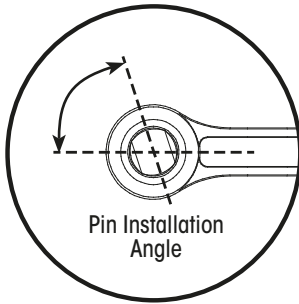

Part Number	Length	Axle	Pin Angle	Notes
64717-605A	605 mm	Front LH	71.7°	230/460. For replacement bushes refer to "230/460 PRIMAAX® Gen II" on page 12.
64717-605B	605 mm	Front RH	108.3°	
64717-645A	645 mm	Rear LH	72.7°	460. For replacement bushes refer to "230/460 PRIMAAX® Gen II" on page 12.
64717-645B	645 mm	Rear RH	107.3°	
67428-425	425 mm	Forward	90°	ULTRA ROD™ – Refer Note [1]
67428-435	435 mm	Forward	90°	ULTRA ROD – Refer Note [1]
67428-445	445 mm	Forward	90°	ULTRA ROD – Refer Note [1]
67428-480	480 mm	Rear	90°	ULTRA ROD – Refer Note [1]

**[1] NOTE:** The 67428-xxx torque rods employ an Axial Retention Feature (ARF) which greatly improves reliability. However, this also means that these bushes cannot be serviced separately.

##### Disc Brake

Torque rod and top pad assemblies are available. Refer table next page.

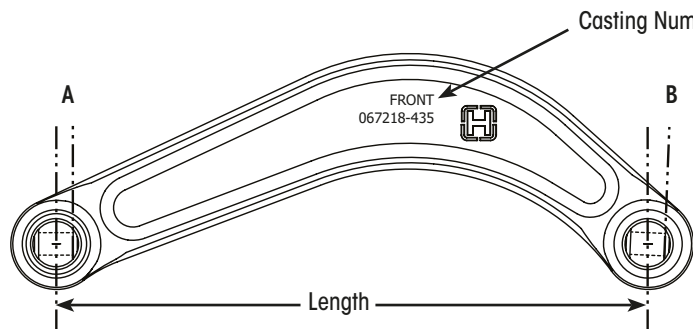

The last three digits of the casting number can help identifying the torque rod.

Part Number	Length	Axle	Angle A	Angle B	Replacement Bush [2]
67219-435	435 mm	Forward	0°	2.5°	47691-000-L
67219-475	475 mm	Rear	0°	11°	47691-000-L

**[2] NOTE:** The one-piece disc brake torque rods can be serviced by replacing the bushes. However, care must be taken on installation to ensure correct bush orientation, with a corresponding pin angle.



**Axle Pad Selection**
**Top Pad**

Part Number	Description	Qty	Notes [3]
65289-000	Top Pad	2	
65289-001	Top Pad – LHS Only	1	
65289-002	Top Pad – RHS Only	1	
65289-003	Top Pad – LHS	1	
65289-004	Top Pad – RHS	1	
65289-005	Top Pad	2	

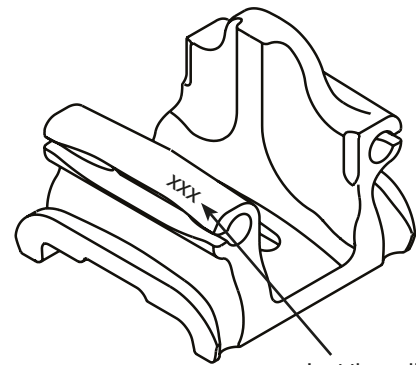

Last three digits of part number stamped here

**[3] NOTE:** Torque rod and top pad assemblies are available. Refer table below.

**Bottom Cap**

Part Number	Description	Qty	Notes
60556-025	Axle Bottom Cap – 2.5 Deg	2	Forward Axle
60556-030	Axle Bottom Cap – 3.0 Deg	2	Forward Axle
60556-035	Axle Bottom Cap – 3.5 Deg	2	Forward Axle
60556-100	Axle Bottom Cap – 10.0 Deg	2	Rear Axle
60556-110	Axle Bottom Cap – 11.0 Deg	2	Rear Axle
60556-115	Axle Bottom Cap – 11.5 Deg	2	Rear Axle
60556-120	Axle Bottom Cap – 12.0 Deg	2	Rear Axle

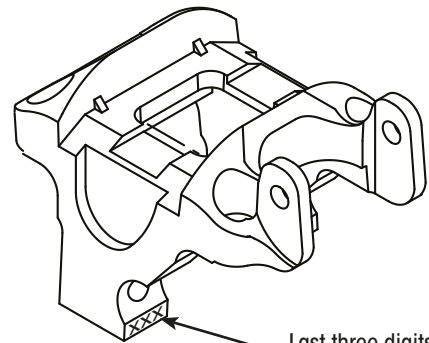

Last three digits of part number stamped here

**Torque Rod & Top Pad Assemblies**

Assembly	Position	Torque Rod	Top Cap	Length	Notes
67430-425A	Left Hand	67428-425	65289-000	425	Drum Brake
67430-425B	Right Hand	67428-425	65289-000	425	Drum Brake
67430-435A	Left Hand	67428-435	65289-000	435	Drum Brake
67430-435B	Right Hand	67428-435	65289-000	435	Drum Brake
97204-436A	Left Hand	67428-435	65289-001	435	Drum Brake
97204-436B	Right Hand	67428-435	65289-002	435	Drum Brake
67430-445A	Left Hand	67428-445	65289-000	445	Drum Brake
67430-445B	Right Hand	67428-445	65289-000	445	Drum Brake
67430-480A	Left Hand	67428-480	65289-000	480	Drum Brake
67430-480B	Right Hand	67428-480	65289-000	480	Drum Brake
68821-101	Left Hand	67219-435	65289-000	435	Disc Brake
68821-102	Right Hand	67219-435	65289-000	435	Disc Brake
68821-301	Left Hand	67219-475	65289-000	475	Disc Brake
68821-302	Right Hand	67219-475	65289-000	475	Disc Brake

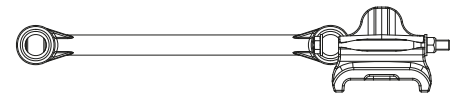

Drum Brake

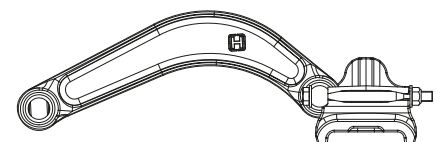

Disc Brake



PRIMAAX® EX 262/522/782 TORQUE RODS & AXLE PADS

Transition/Straight Identification

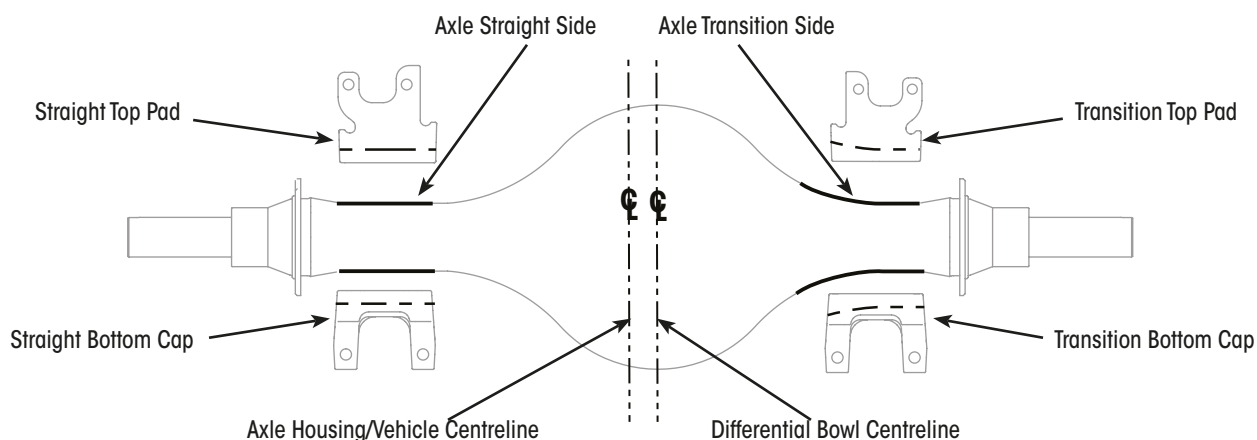

The differential bowl is offset from the centre of the axle housing centreline. This creates a transition area on one side of the axle where the axle housing is not straight at the point it meets the suspension. The transition side will typically be on opposite sides between front axle and rear axle.

Bottom Cap

The last three identifying digits of the part number, followed with the angle, are stamped into the lower machined surface of each bottom cap.

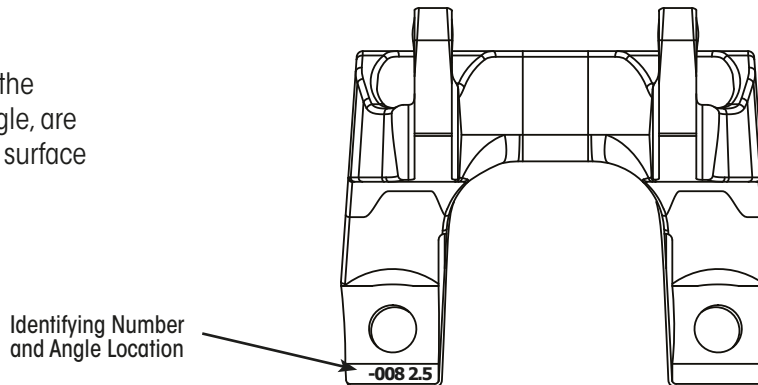

Part Number	Axle	Angle	Side	Position
65208-002	Dana	2.5°	Straight Side	Left Front
65208-004	Dana	10.0°	Straight Side	Right Rear
65208-008	Dana	2.5°	Transition Side	Right Front
65208-011	Dana	10.0°	Transition Side	Left Rear
65208-101	Meritor	2.5°	Straight Side	Left Front
65208-103	Meritor	10.0°	Straight Side	Right Rear
65208-106	Meritor	2.5°	Transition Side	Right Front
65208-109	Meritor	10.0°	Transition Side	Left Rear

**Top Pad**

Top pads have a casting number located on the bottom surface, which links to the part number. Refer to the table for details.

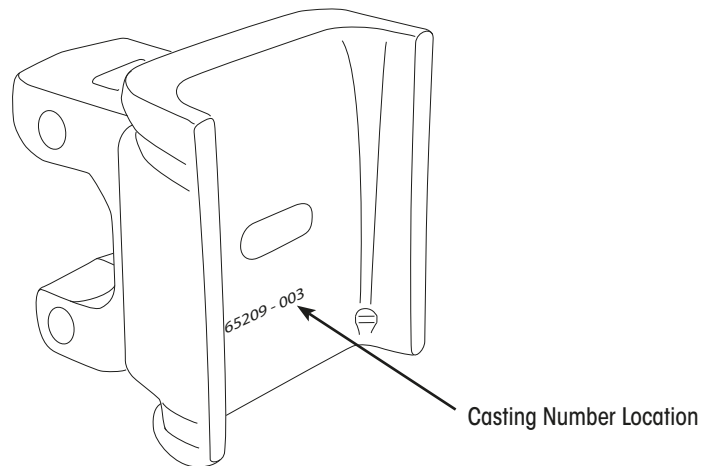

Part Number	Casting Number	Axle	Position
65210-001	65209-001	Meritor	Straight Side
65210-003	65209-003	Meritor	Transition Side
65210-002	65209-002	Dana	Straight Side
65210-004	65209-004	Dana	Transition Side

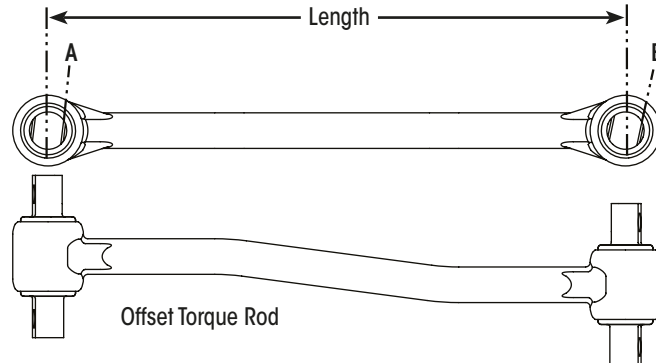
**Longitudinal Torque Rod**

Part Number	Description	Position	Length	Bush Angle – A	Bush Angle – B
65302-480A	Offset Torque Rod	Left Hand Front	480 mm	5.4°	8.3°
65302-480B	Offset Torque Rod	Right Hand Front	480 mm	5.4°	8.3°
65302-530A	Offset Torque Rod	Left Hand Rear	530 mm	7°	19°
65302-530B	Offset Torque Rod	Right Hand Rear	530 mm	7°	19°

**NOTE:** These torque rods have non-serviceable bushes that require replacement of complete torque rod assemblies.



230/460 PRIMAAX® GEN II

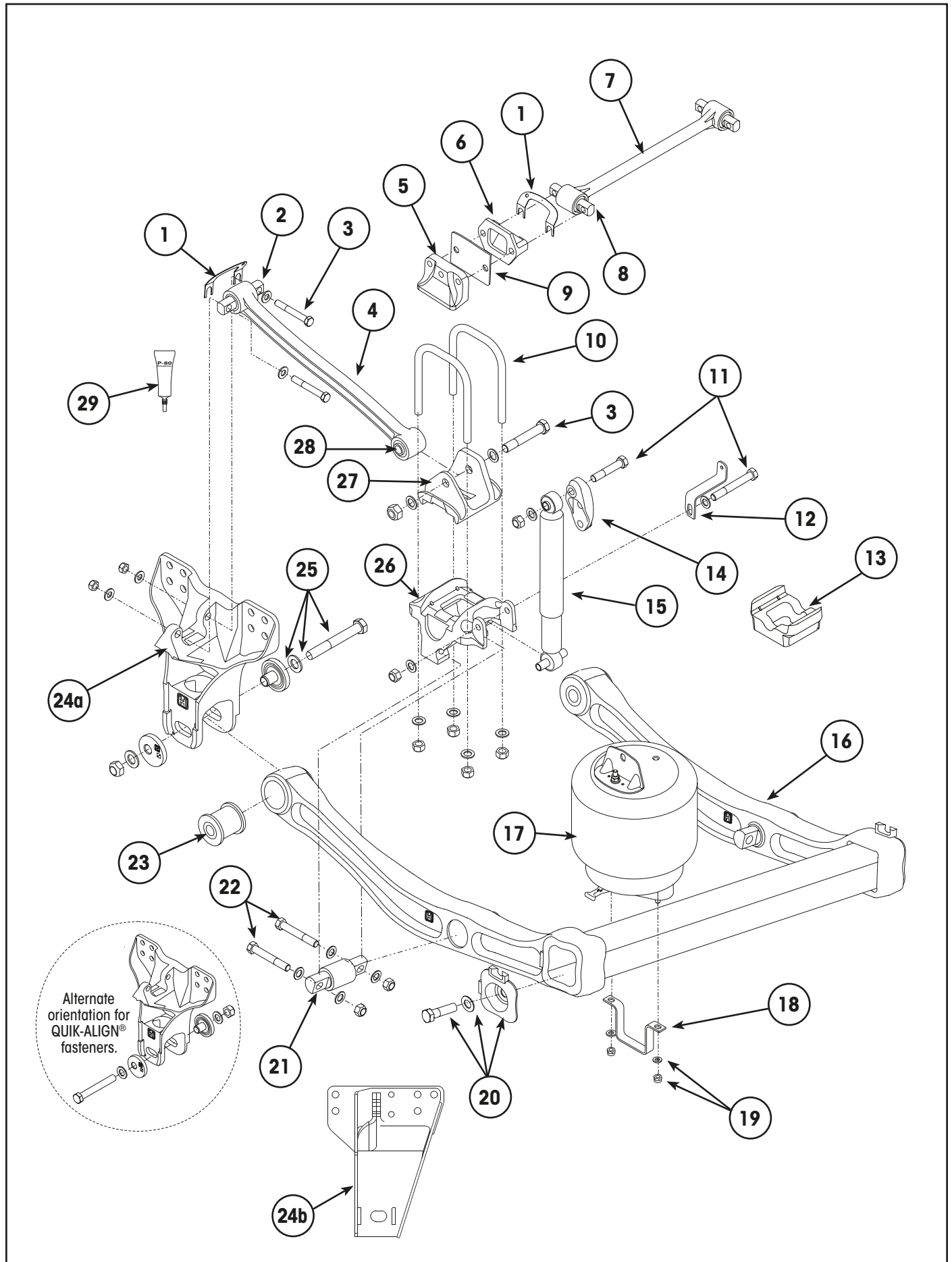

**230/460 PRIMAAX® GEN II**

Item	Part Number	Description	Qty	Notes
1	49689-000	Torque Rod Shim	AR	1.52 mm shim thickness.
2	69210-000	Straddle Bar Pin Bush	2	3/4" holes. Included in item 4.
3	49176-008	Longitudinal Torque Rod Fastener Kit	1	Includes bolts, nuts & washers.
4	–	Longitudinal Torque Rod	1	Refer "Longitudinal Torque Rod" on page 8. Includes items 2 & 26.
5	60593-000	Frame Mounted Axle Stop	2	
6	22186-000	Transverse Torque Rod Bracket Frame	1	
7	62000-565	Transverse Torque Rod – 565 mm	1	Includes bushes, item 8.
8	47691-000-L	Torque Rod Bush, 50 mm	2	Included in item 7.
9	45045-002	Transverse Bracket Spacer – 6 mm	AR	As required for application.
10	91430-047	225 mm U-Bolt Kit – To Suit 10" Ride Height	2	Services one side only. Includes nuts & washers. Refer to "Ride Height" on page 5.
	91430-048	264 mm U-Bolt Kit – To Suit 8" Ride Height	2	
11	50754-007	Shock Absorber Mounting Hardware Kit	1	Includes bolts, nuts & washers.
12	–	Height Control Valve Linkage Bracket	1	Refer to "Height Control Valve" on page 19.
13	65139-003	Axle Cap Spacer – Suits 8" Ride Height	2	Refer to "Ride Height" on page 5.
14	67463-002	Upper Shock Frame Bracket	2	
15	98583-068	Shock Absorber – Upgrade	2	Enhanced design, replaces 98583-032.
16	60961-235	U-Beam Service Kit – Forward	1	Includes updated PRIMAAX EX beam design, air spring, air spring bracket & fastener, D-pin hardware & standard 1" QUIK-ALIGN® fastener.
	60961-236	U-Beam Service Kit – Rear	1	
17	60271-002	Air Spring Assembly	2	Includes upper frame bracket.
18	60911-002	Lower Air Spring Mounting Bracket	2	
19	98111-012-P	Air Spring Hardware Kit	2	Includes two each 1/2" nut & washer.
20	46772-001	End Cap and Fastener Kit – Axle Set	1	Includes end caps, bolts & washers. Not required if replacing beam (item 16).
21	60383-000	Single D-Pin	2	D-pin only.
	34013-107	D-Pin Service Kit – 127 mm (5") Bolts	2	Includes D-pin, bolts, washers & nuts.
22	56659-009	D-Pin Hardware Kit – 127 mm (5") Bolts	1	Axle set. Includes bolts, washers & nuts.
23	–	QUIK-ALIGN® Pivot Bush	2	Refer "Pivot Hardware Kits" on page 7.
24a	60821-001	Frame Hanger – Cast	2	
24b	97109-001	Frame Hanger – Fabricated Left Hand	1	
	97109-002	Frame Hanger – Fabricated Right Hand	1	
25	–	QUIK-ALIGN Collars & Fasteners	2	Refer "Pivot Hardware Kits" on page 7.
26	–	Bottom Cap	2	Refer to "Bottom Cap" on page 9.
27	60877-001	Top Pad	2	
28	47692-000-L	Torque Rod Bush	2	Through-hole type. Included in item 4.
29	70867-001	P-80 Bush Installation Lubricant – 10 ml	–	One tube required per rubber bush.



232/462/692 PRIMAAX® EX

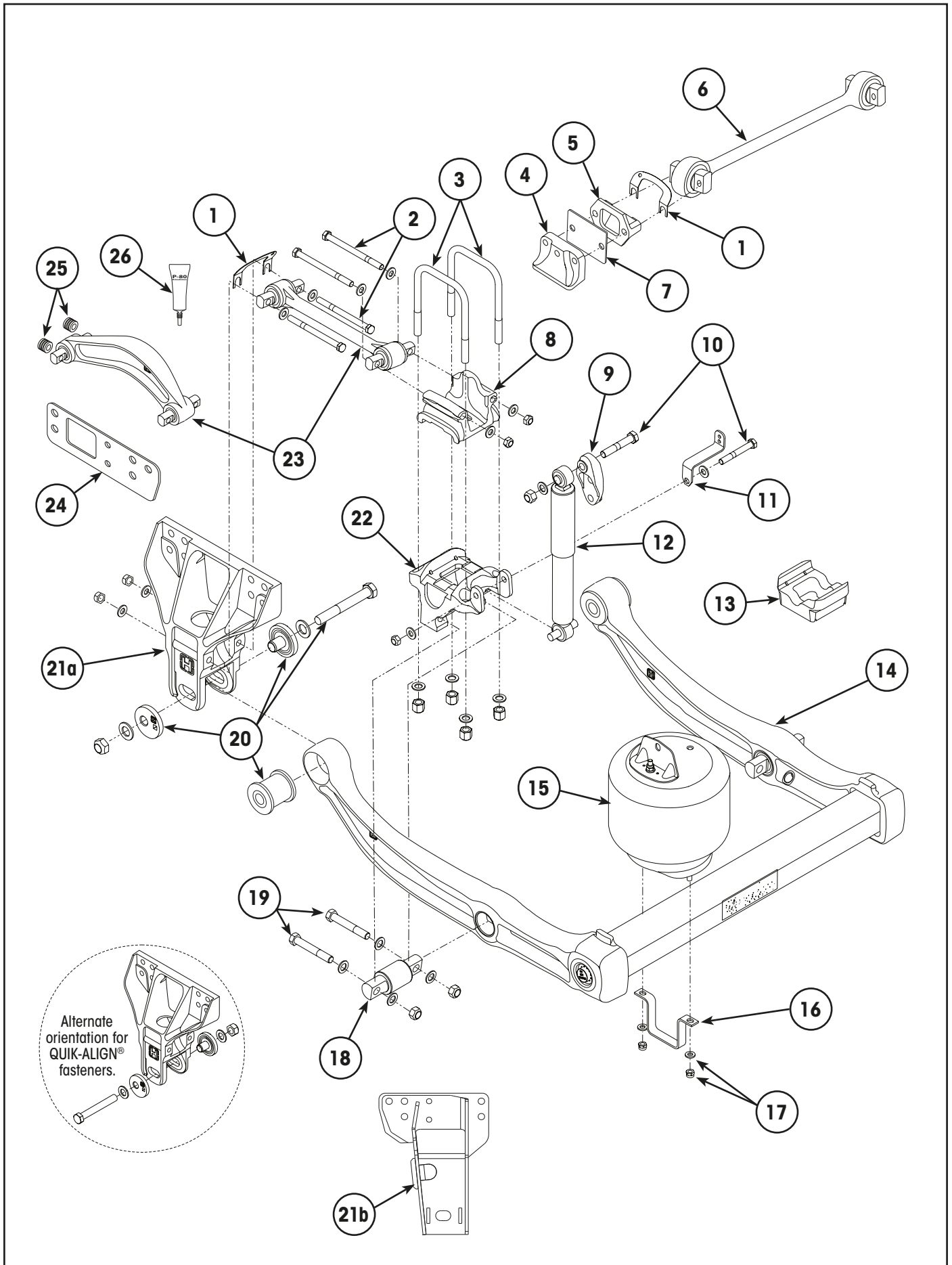

**232/462/692 PRIMAAX® EX**

Item	Part Number	Description	Qty	Notes
1	49689-000	Torque Rod Shim	AR	1.52 mm shim thickness.
2	49176-032	Torque Rod Fastener Kit – Cast Hanger	2	Includes bolts, nuts & washers.
	98111-144	Torque Rod Fastener Kit – Fabricated Hanger	2	Includes bolts, nuts & washers.
3	91430-047	225 mm U-Bolt Kit – To Suit 10" Ride Height	2	Services one side only. Includes nuts & washers. Refer to "Ride Height" on page 5.
	91430-048	264 mm U-Bolt Kit – To Suit 8" Ride Height	2	
4	60593-000	Frame Mounted Axle Stop	2	
5	22186-000	Transverse Torque Rod Bracket Frame	1	
6	58745-003	Transverse Torque Rod – 605.9 mm	1	ULTRA ROD™ PLUS. Includes bushes, which are not separately replaceable.
	58745-007	Transverse Torque Rod – 635 mm	1	
7	45045-002	Transverse Bracket Spacer Plate – 6 mm	AR	As required for application.
8	–	Top Pad	2	Refer to "Axle Pad Selection" on page 9.
9	67463-002	Upper Shock Frame Bracket	2	
10	50754-007	Shock Absorber Mounting Hardware Kit	1	Includes bolts, nuts & washers.
11	–	Height Control Valve Linkage Bracket	1	Refer to "Height Control Valve" on page 19.
12	98583-068	Shock Absorber – Upgrade	2	Enhanced design, replaces 98583-032.
13	65139-003	Axle Cap Spacer – Suits 8" Ride Height	2	Refer to "Ride Height" on page 5.
14	67249-004	U-Beam Assembly – Front (& Middle for Tridem)	1	Pivot bush suits standard 1" bolt. Includes QUIK-ALIGN® bushes & D-pins..
	67249-003	U-Beam Assembly – Rear	1	
	97795-002	U-Beam Assembly – Front	1	Pivot bush suits larger 1¼" bolt. Includes QUIK-ALIGN bushes & D-pins.
	97795-001	U-Beam Assembly – Rear	1	
15	98734-094	Air Spring Assembly	2	Includes upper frame bracket.
16	60911-002	Lower Air Spring Mounting Bracket	2	
17	98111-012-P	Air Spring Hardware Kit	2	Includes two each 1/2" nut & washer.
18	60383-000	Single D-Pin	2	D-pin only.
	34013-107	D-Pin Service Kit – with 127 mm (5") Bolts	2	Includes D-pin, bolts, washers & nuts.
19	56659-009	D-Pin Hardware Kit – 127 mm (5") Bolts	1	Axle set. Includes bolts, washers & nuts.
20	–	QUIK-ALIGN® Pivot Bush, Collar & Fastener	2	Refer "Pivot Hardware Kits" on page 7.
21a	67706-000	Frame Hanger – Cast	2	
21b	97109-009	Frame Hanger - Fabricated LH	1	
	97109-010	Frame Hanger - Fabricated RH	1	
22	–	Bottom Cap	2	Refer "Axle Pad Selection" on page 9.
23	–	Longitudinal Torque Rod	1	Refer "Longitudinal Torque Rod" on page 8.
24	97111-011	Spacer Plate – 8 mm	2	For fabricated hanger only.
25	22962-004-4P	Kit, 4 Pack Hardened Washer – 3 mm	AR	As required, depending on application.
	67045-071	Torque Rod Spacer – 12.7 mm	4	
26	70867-001	P-80 Bush Installation Lubricant – 10 ml	–	One tube required per rubber bush.



262/522/782 PRIMAAX® EX

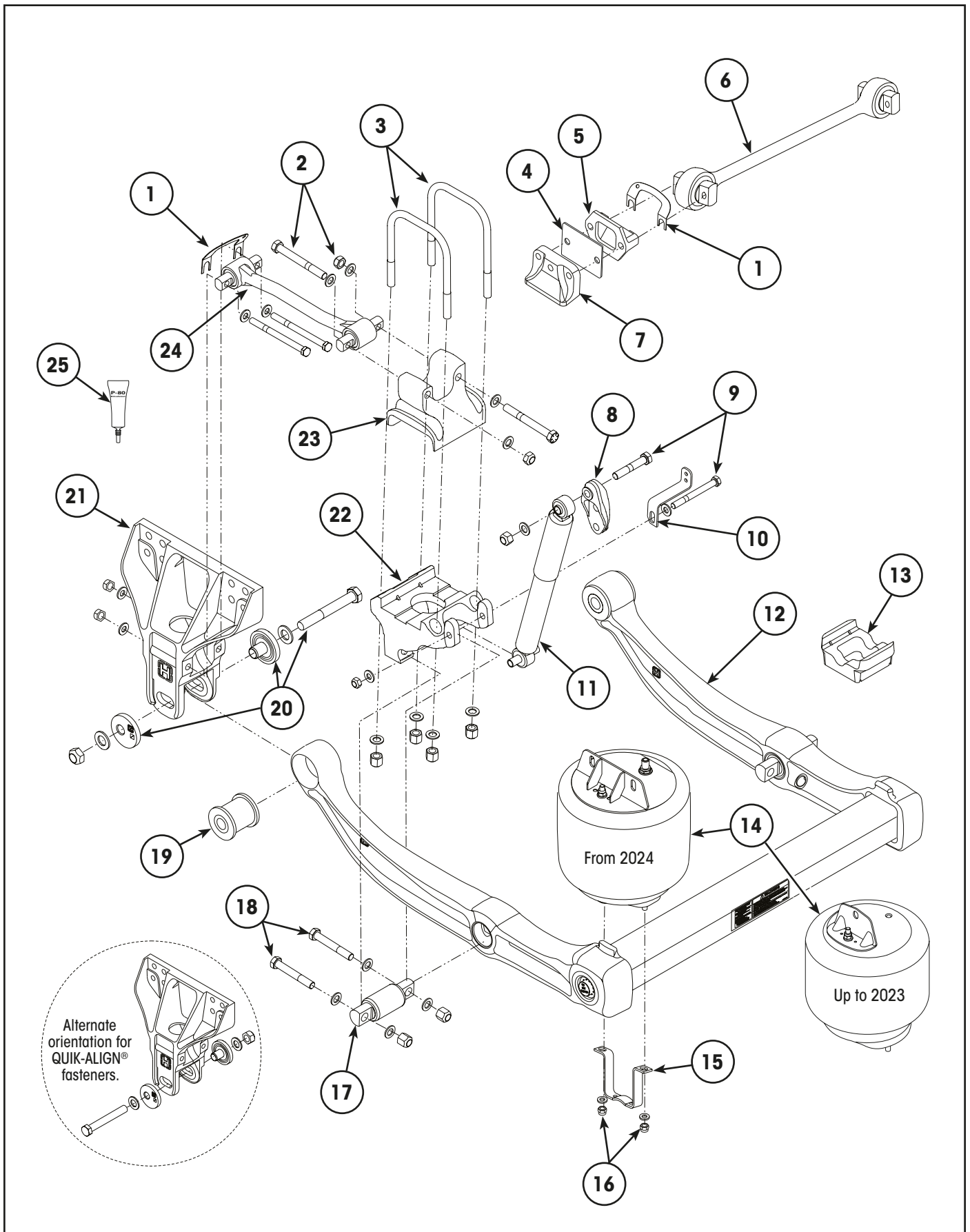



**262/522/782 PRIMAAX® EX**

Item	Part Number	Description	Qty	Notes
1	49689-000	Torque Rod Shim	AR	1.52 mm shim thickness.
2	49176-031	Torque Rod Fastener Kit – Cast Hanger	2	Includes bolts, nuts & washers.
3	91430-042	10" U-Bolt Partial Kit – To Suit 10" Ride Height	1	Both kits required to service one axle. Includes nuts & washers. Refer to "Ride Height" on page 5.
	91430-043	10.5" U-Bolt Partial Kit – To Suit 10" Ride Height	1	
	91430-045	10.5" U-Bolt Partial Kit – To Suit 8" Ride Height	1	Both kits required to service one axle. Includes nuts & washers. Refer to "Ride Height" on page 5.
	91430-060	11.5" U-Bolt Partial Kit – To Suit 8" Ride Height	1	
4	45045-002	Transverse Bracket Spacer Plate – 6 mm	AR	As required for application.
5	22186-000	Transverse Torque Rod Bracket Frame	1	
6	58745-003	Transverse Torque Rod – 605.9 mm	1	ULTRA ROD™ PLUS. Includes bushes, which are not separately replaceable.
	58745-007	Transverse Torque Rod – 635 mm	1	
7	60593-000	Frame Mounted Axle Stop	2	
8	67463-002	Upper Shock Frame Bracket	2	
9	50754-036	Shock Absorber Mounting Hardware Kit	1	Includes bolts, nuts & washers.
10	–	Height Control Valve Linkage Bracket	1	Refer to "Height Control Valve" on page 19.
11	98583-069	Shock Absorber – 262/522/782	2	Replaces 98583-067.
12	67249-006	U-Beam Assembly Standard Service – Front	1	Includes QUIK-ALIGN® bushes & D-pins.
	67249-005	U-Beam Assembly Standard Service – Rear	1	
	97795-004	U-Beam Assembly Severe Service – Front	1	Includes QUIK-ALIGN bushes & D-pins.
	97795-003	U-Beam Assembly Severe Service – Rear	1	
13	65276-000	Axle Cap Spacer – Meritor Axle Straight Side	1	To suit 8" Ride Height. Refer to "Ride Height" on page 5.
	65277-000	Axle Cap Spacer – Meritor Axle Transition Side	1	
14	98734-094	Air Spring Assembly – Up to 2023	2	Includes single mounting hole frame bracket.
	67247-002	Air Spring Assembly – From 2024	2	Includes double mounting hole frame bracket.
15	60911-002	Lower Air Spring Mounting Bracket	2	
16	98111-012-P	Air Spring Hardware Kit	2	Includes two each 1/2" nut & washer.
17	65381-000	Single D-Pin	2	D-pin only.
	34013-114	D-Pin Single Side Service Kit	2	Includes D-pin, bolts, washers & nuts.
18	56659-010	D-Pin Hardware Kit – 100 mm (5") Long Bolts	1	Includes bolts, washers & nuts.
19	–	QUIK-ALIGN® Pivot Bush	2	Refer "Pivot Hardware Kits" on page 7.
20	–	QUIK-ALIGN Collars & Fasteners	2	
21	67706-000	Frame Hanger – Cast	2	
22	–	Bottom Cap	2	Refer to "Bottom Cap" on page 10
23	–	Top Pad	2	Refer to "Top Pad" on page 11.
24	–	Longitudinal Torque Rod	1	Refer "Longitudinal Torque Rod" on page 11.
25	70867-001	P-80 Bush Installation Lubricant – 10 ml	–	One tube required per rubber bush.



This page is intentionally left blank.

## HEIGHT CONTROL VALVE

**NOTICE:** Haldex height control valves exhaust air through a port at the shaft. The valves may continue to exhaust air past the shaft for several minutes after a vehicle has stopped until the vehicle height stabilises. This is a normal operating function of the HCV and does not indicate that the valve is faulty.

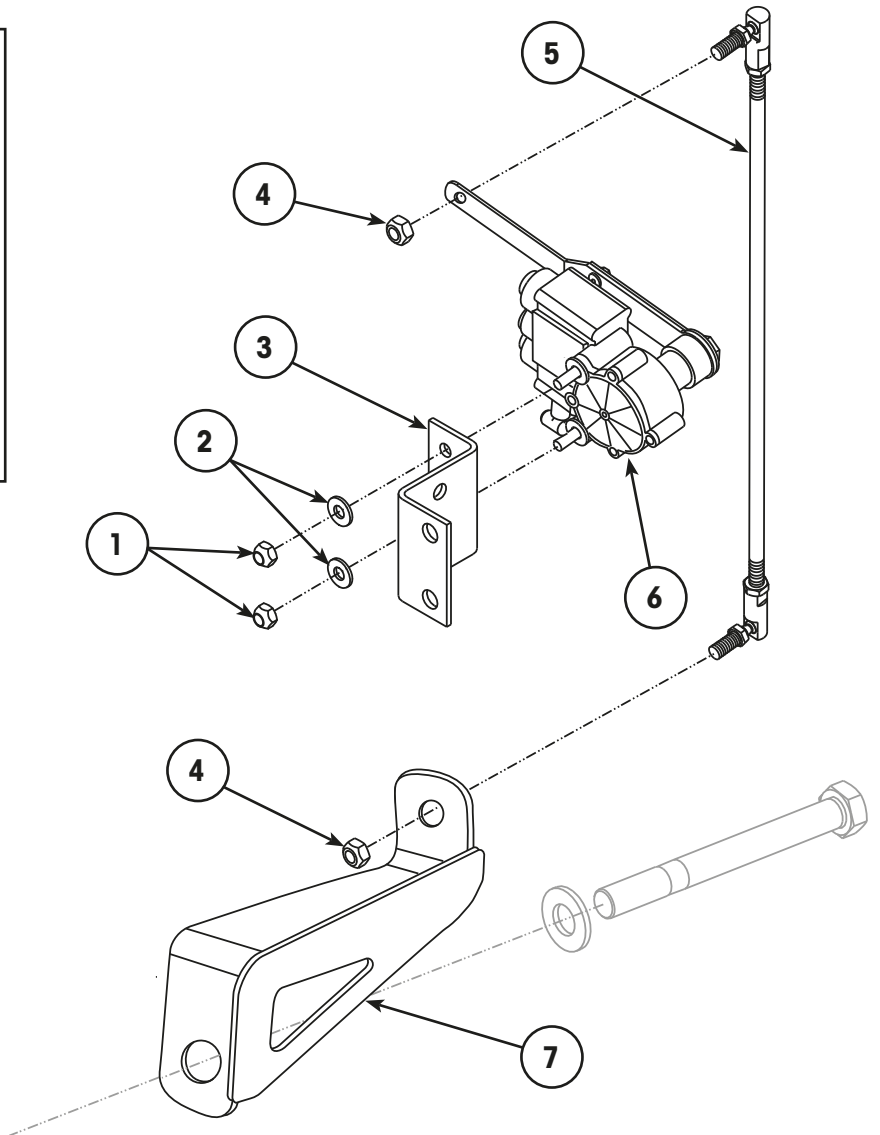

Item	Part Number	Description	Qty	Notes
1	NSS	Nut – 1/4-20 UNC	2	Use item 6 or 9.
2	NSS	Washer – 1/4 Inch	2	Use item 6 or 9.
3	57975-000	Height Control Valve Bracket	AR	Included in item 9.
4	NSS	Nut – 5/16"-24 UNF	2	Use item 5.
5	98600-389	HCV Rod – 389 mm	1	Includes item 4.
	98600-400	HCV Rod – 400 mm	1	Includes item 4.
6	98603-008	Height Control Valve – 3/8" Air Line	AR	Includes items 1 & 2. Included in item 8.
7	98677-012	HCV Rod Bracket - Lower	1	Attaches to left lower shocker bolt.
8	98606-060	Kit, Height Control Valve Kit Not Illustrated	1	Single HCV kit. Includes items 1, 2, 3 & 6.
	98606-365		1	Dual HCV kit. Includes items 1, 2, 3 & 6.



## SPECIAL TOOLS

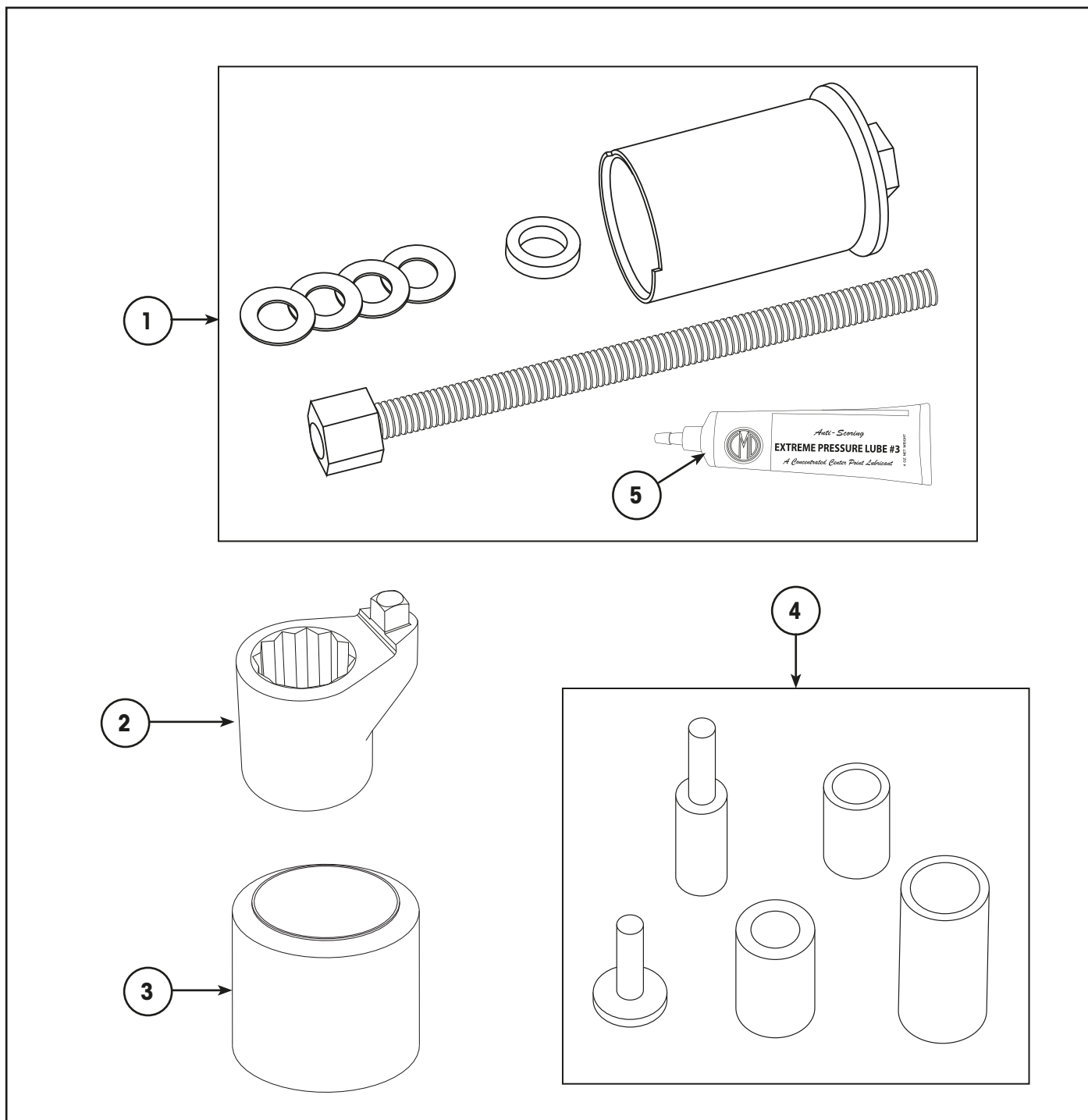

Item	Part Number	Description	Notes
1	66086-203	PRIMAAX® QUIK-ALIGN® Pivot Bush Tool	For 'in situ' replacement of pivot bushes. Includes extreme pressure lubricant for tool thread.
2	66086-200	Alignment Socket	
3	98596-020-P	Torque Rod Re-Bush Tool	Suits disc brake torque rod bushes – 47691-000-L.
4	97328-000	D-Pin & QUIK-ALIGN Hydraulic Press Tools	For use with U-beam assembly removed.
5	S-21337	Extreme Pressure Lubricant	For use with bush tool thread, item 1.

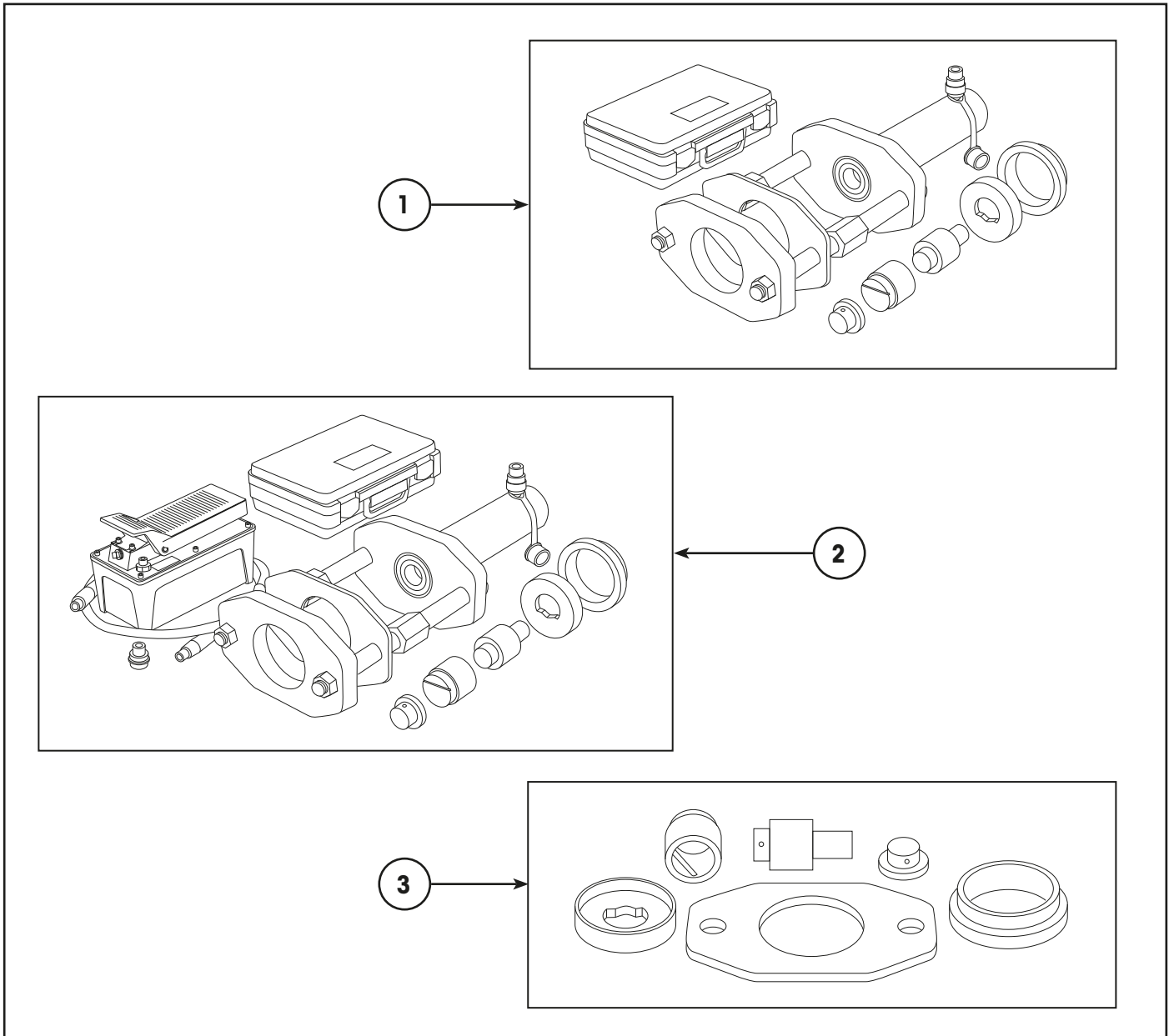
**SPECIAL TOOLS**

Item	Part Number	Description	Notes
1	66086-202	Rear Suspension Bush Tool Kit.	<b>OTC 4246.</b> Removes and installs Pivot and D-Pin Bushes for PRIMAAX® EX and COMFORT AIR™ suspensions. Includes adapters to align tool with the suspension to ensure proper bush installation. Mounting system designed so that tool does not need to be held during operation. Includes an OTC 4106A 25-ton high-force cylinder.
2	66086-204	Rear Suspension Bush Master Kit with Pump.	<b>OTC 4247.</b> Complete 66086-202 kit with the addition of an OTC 2510A air/hydraulic pump to make bush service faster and easier.
3	66086-205	Rear Suspension Adapter Kit	<b>OTC 4254.</b> Adapter kit to convert OTC kits 4274 and 4275 for use with Pivot and D-Pin Bushes on PRIMAAX EX, COMFORT AIR suspensions.

**NOTE:** If using a press to replace bushes or D-pins, it is possible to fabricate your own suitable tools. Reference drawings to make these tools are available in Hendrickson PRIMAAX EX Maintenance bulletin [97117-212](#).



## REVISIONS TABLE

DATE	REV	PAGE	DESCRIPTION
Sep-2020	F	5,8,13,15,17	Add note for 230/460 longitudinal bushes. Add P-80 lubricant.
Sep-2020	F	5,13,15,17	Add 8" ride height, ECN 11569, 11594. Add upgrade shocks, ECN 11476, 11679.
Sep-2020	F	3	Amend suspension capacity table.
Oct-2021	G	12, 14	Add fabricated hanger illustrations.
Oct-2021	G	15, 17	Remove obsolete beam service kit, ECN 11871. Update torque rod fasteners.
Oct-2021	G	7	Update pivot connection hardware, ECN 11878.
Oct-2021	G	8	Remove not available torque rod.
Oct-2021	G	13, 15, 17	Update U-bolt kit numbers, ECN 11718.
Jul-2022	H	8	Update offset torque rod numbers to 64717-xxx, ECN 11961.
Jul-2022	H	17, 19	Add 400mm HCV rod & new shocks, ECN 11680.
Feb-2024	I	16, 17	Add upgraded air springs, ECN 12103.
Mar-2024	J	8, 9	Add torque rod & top pad assemblies.

*Actual product performance may vary depending upon vehicle configuration, operation, service and other factors.  
All applications must comply with applicable Hendrickson specifications and must be approved by the respective vehicle manufacturer with the vehicle in its original, as-built configuration.  
Contact Hendrickson for additional details regarding specifications, applications, capacities, and operation, service and maintenance instructions.*

**Need Help? Australia Call +61 3 8792 3600 or Email [customerservice@hendrickson.com.au](mailto:customerservice@hendrickson.com.au)  
New Zealand Call +64 9 570 4721 or Email [nz-customerservice@hendrickson.co.nz](mailto:nz-customerservice@hendrickson.co.nz)**



**HENDRICKSON ASIA PACIFIC**  
ABN 21 004 992 769  
32- 44 Letcon Drive, P.O. Box 1063  
Dandenong, Victoria, 3175  
61.3.8792.3600 • Fax 61.3.8792.3699

**HENDRICKSON NEW ZEALAND**  
Unit P, 24 Allright Place  
Mt Wellington, Auckland, 1060  
64.9.570.4721 • Fax 64.9.570.4816

[www.hendrickson.com.au](http://www.hendrickson.com.au)