



H ASSEMBLY INSTRUCTIONS

AIRTEK for Freightliner Vehicles Built Prior to May 2016

SUBJECT: Leaf Spring and Shackle Bracket
Assembly Replacement Service Kits

LIT NO: 59310-065

DATE: April 2017

REVISION: B

INTRODUCTION

CONTENTS OF REPLACEMENT SERVICE KITS

DESCRIPTION	QTY.
Leaf Spring Assembly	1
Shackle Bracket Assembly	1

This publication is intended to assist maintenance personnel with the installation, on an as-needed basis, of the following leaf spring and shackle bracket assembly replacement service kits for AIRTEK integrated front air suspensions and STEERTEK NXT / STEERTEK axles equipped on applicable Freightliner vehicles built **PRIOR** to May 2016.

In May 2016, Hendrickson introduced enhancements to the leaf spring and shackle bracket assemblies for AIRTEK systems used in new Freightliner production vehicles. Hendrickson no longer offers the following previous leaf spring assemblies and shackle bracket assembly for aftermarket service purposes.

LEAF SPRING AND SHACKLE BRACKET ASSEMBLIES

	*Replacement Service Kits				Previous Leaf Spring Assemblies			
	SET BACK		SET FORWARD		SET BACK		SET FORWARD	
Front Spring Eye Equipped with:	Left Hand	Right Hand	Left Hand	Right Hand	Left Hand	Right Hand	Left Hand	Right Hand
Thru Bolt Bushing	60961-827	60961-828			59930-061	59930-062		
Bar Pin Bushing	60961-844	60961-845	60961-846	60961-847	59930-057	59930-058	59930-059	59930-060

NOTE: * These replacement service kits include a new leaf spring assembly and, as applicable, a left hand shackle bracket assembly (Part No. 68274-003) or right hand shackle bracket assembly (Part No. 68274-004), both of which replace a common shackle bracket assembly (Part No. 68274-001) previously used on both the left and right sides.

The new designs for the leaf spring and shackle assemblies are not compatible with these previous assemblies. Therefore, on AIRTEK equipped Freightliner vehicles built prior to May 2016, if the original leaf spring assembly or the shackle bracket assembly require replacement, both assemblies for that side of the suspension will need to be replaced by using one of the above-referenced service kits. It is not necessary to replace both sides if only one side requires service.

NOTE

Once the conversion to current production components are made, shackle bracket and/or leaf spring assembly can be replaced individually for service.

Refer to Hendrickson Publication No. 17730-243 for complete service and safety instructions for the AIRTEK front suspension system.

⚠ WARNING

A TECHNICIAN USING A SERVICE PROCEDURE OR TOOL WHICH HAS NOT BEEN RECOMMENDED BY HENDRICKSON MUST FIRST SATISFY HIMSELF THAT NEITHER HIS SAFETY NOR THE VEHICLE'S SAFETY WILL BE JEOPARDIZED BY THE METHOD OR TOOL SELECTED. INDIVIDUALS DEVIATING IN ANY MANNER FROM THE INSTRUCTIONS PROVIDED WILL ASSUME ALL RISKS OF CONSEQUENTIAL PERSONAL INJURY OR DAMAGE TO EQUIPMENT INVOLVED.



LEAF SPRING & SHACKLE REPLACEMENT

DISASSEMBLY

1. Place the vehicle on level floor.
2. Chock the wheels.

WARNING

AIR SPRING ASSEMBLIES MUST BE DEFLATED PRIOR TO LOOSENING ANY CLAMP GROUP HARDWARE. UNRESTRICTED AIR SPRING ASSEMBLIES CAN VIOLENTLY SHIFT. DO NOT INFLATE AIR SPRING ASSEMBLIES WHEN THEY ARE UNRESTRICTED. AIR SPRING ASSEMBLIES MUST BE RESTRICTED BY SUSPENSION OR OTHER ADEQUATE STRUCTURE. DO NOT INFLATE BEYOND PRESSURES RECOMMENDED BY AIR SPRING MANUFACTURER, CONTACT HENDRICKSON TECHNICAL SERVICES FOR DETAILS. IMPROPER USE OR OVER INFLATION MAY CAUSE AIR SPRING ASSEMBLIES TO BURST, CAUSING PROPERTY DAMAGE AND/OR SEVERE PERSONAL INJURY.

3. Deflate the air springs by removing the height control valve linkage and lowering the leveling valve arm. This will exhaust the air pressure in the air springs.
4. Install a floor jack with a 4" lifting plate below the axle and raise the truck.
5. Remove the tires.
6. Support the frame.
7. Lower the jack allowing the axle to hang, but **DO NOT** remove the jack from the axle.
8. Loosen, but **DO NOT** remove the ¾" front spring eye bolts.
9. Remove both rear spring mount ¾" hex bolts.
10. Remove both lower shock absorber mounting bolts.
11. Disconnect both air springs from the top pad of the clamp group.
12. Loosen the ¾" clamp group locknuts for the leaf spring that is not being replaced.

WARNING

DO NOT USE A CUTTING TORCH TO REMOVE CLAMP GROUP BOLTS OR ATTACHING FASTENERS. THE USE OF SUCH HEAT ON SUSPENSION COMPONENTS CAN ADVERSELY AFFECT THE STRENGTH OF THESE PARTS. A COMPONENT DAMAGED IN THIS MANNER CAN RESULT IN THE LOSS OF VEHICLE CONTROL AND POSSIBLE PERSONAL INJURY OR PROPERTY DAMAGE.

13. Remove and discard the ¾" clamp group locknuts from the spring(s) being replaced.
14. If equipped with:
 - a. **STEERTEK NXT** axle (after November 2011) — Remove the top pad, from the leaf spring assembly, see Figure 3. **DO NOT** remove, modify or replace integrated axle spring seat or fasteners.
 - b. **STEERTEK** axle (prior to November 2011) — Remove the top pad, front axle spacer, and the bottom axle wrap from the leaf spring that is going to be removed, see Figure 4.
15. Lower the jack allowing the suspension to pivot down out of the rear shackles.
16. Remove the ¾" front spring eye bolt from the leaf spring that is being removed.
17. Remove the leaf spring assembly. Approximate weight of the leaf spring is 48 pounds.
18. Remove the old frame hanger bracket and aluminum shackle.

ASSEMBLY

1. Install the new frame hanger bracket and steel shackle.
2. Lubricate the front spring eye bushing and the front hanger with a vegetable base oil (cooking oil). **DO NOT** use petroleum or soap base lubricant, it can cause an adverse reaction with the spring eye bushing material.
3. Install the spring over the axle and into the front spring hanger.
4. Install the ¾" front spring eye bolt and fastener, but **DO NOT** tighten.
5. If equipped with **STEERTEK NXT** axle
 - a. Install the front axle spacer and new leaf spring assembly with galvanized liner onto the axle. Verify that the dowel pin is engaged properly in the axle spring seat, see Figure 3.
 - b. Install the original top pad onto the leaf spring assembly.
 - c. Proceed to Step 6.



AIRTEK for Freightliner Leaf Spring and Shackle Bracket Assembly

FIGURE 3

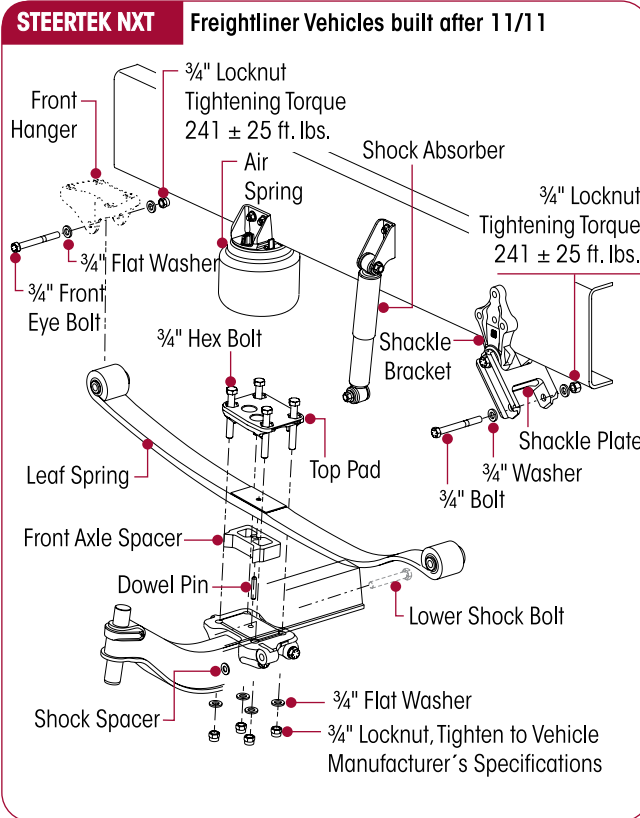
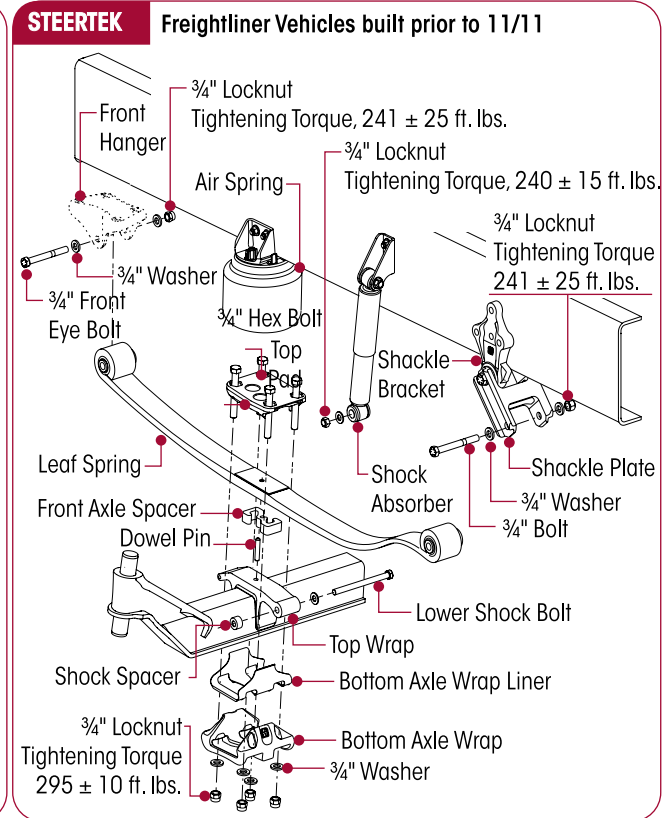

FIGURE 4



6. If equipped with **STEERTEK** axle
 - a. Install the front axle spacer and new leaf spring assembly with galvanized liner onto the axle over dowel pin located on the top axle wrap, see Figure 4. It may be necessary to loosen the other clamp group to allow the axle to pivot when installing the leaf spring on the dowel pin.
 - b. Install the original top pad onto the leaf spring assembly.
 - c. Remove and replace the bottom axle wrap liner located inside the bottom axle wrap.
 - d. Install the new bottom axle wrap, see Figure 4.
7. Install the new 3/4" clamp group bolts, washers, and the new locknuts. The locknuts must be replaced when the clamp group is removed, to prevent premature bolt fatigue.
8. Snug the clamp group, **DO NOT** torque at this time.
9. Raise the axle and the rear spring assembly into the rear spring shackle.
10. Install the 3/4" rear spring eye bolts in the shackle.
11. Snug both front and rear spring eye bolts.
12. Tighten the lower shock mounting bolts to:
 - STEERTEK NXT** axle – per vehicle manufacturer's torque specifications.
 - STEERTEK** axle – 240 ± 15 foot pounds torque.
13. Install air springs into the top pads. Make sure the air spring piston seats into the top pad correctly.
14. Install the tires.
15. Remove the frame supports and load the front axle with the trucks weight.

WARNING

UNRESTRICTED AIR SPRING ASSEMBLIES CAN VIOLENTLY SHIFT. DO NOT INFLATE AIR SPRING ASSEMBLIES WHEN THEY ARE UNRESTRICTED. AIR SPRING ASSEMBLIES MUST BE RESTRICTED BY SUSPENSION OR OTHER ADEQUATE STRUCTURE. DO NOT INFLATE BEYOND PRESSURES RECOMMENDED BY AIR SPRING MANUFACTURER, CONTACT HENDRICKSON TECHNICAL SERVICES FOR DETAILS. IMPROPER USE OR OVER INFLATION MAY CAUSE AIR SPRING ASSEMBLIES TO BURST, CAUSING PROPERTY DAMAGE AND/OR SEVERE PERSONAL INJURY.

16. Air up system.
17. Verify the vehicle is at the proper ride height. See Alignment and Adjustment Section in Hendrickson Publication No. 17730-243.

FIGURE 5

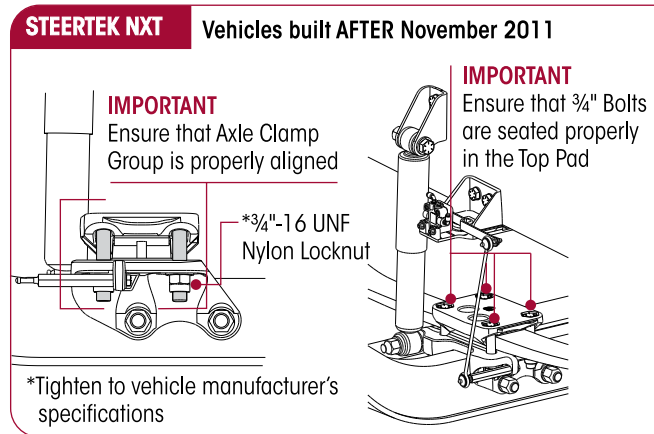
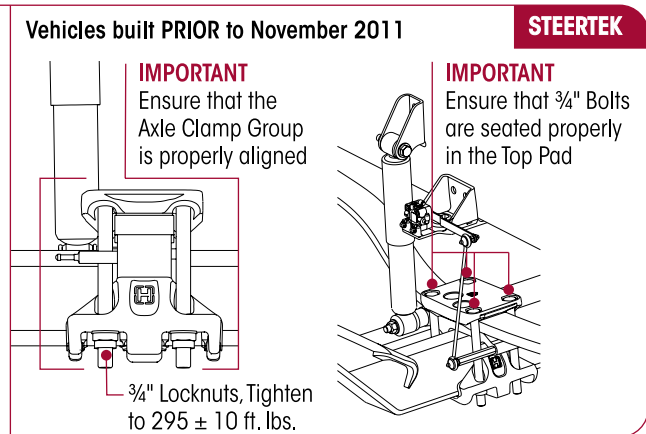

FIGURE 6



18. If equipped with **STEERTEK NXT** axle

- a. Ensure that the clamp group is properly aligned and the hex bolts are seated in the top pad, and the top pad is centered with the axle spring seat see Figure 5.
- b. Tighten the clamp group locknuts evenly in 50 foot pounds increments in the proper pattern to achieve uniform bolt tension, see Figure 7, to vehicle manufacturer's specifications.
- c. Proceed to Step 13.

FIGURE 7

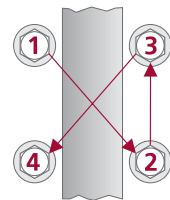

19. If equipped with **STEERTEK** axle

- a. Ensure that the clamp group is properly aligned and the hex bolts are seated in the top pad, and the bottom axle wrap is centered with the top axle wrap and top pad, see Figure 6.
- b. Tighten the clamp group locknuts evenly in 50 foot pounds increments to 295 ± 10 foot pounds torque in the proper sequence to achieve uniform bolt tension, see Figure 7.

20. Remove the wheel chocks.

Refer any questions on this publication to Hendrickson Tech Services



Toll-free U.S. and Canada
1.866.755.5968
Outside U.S. and Canada
1.630.910.2800



Parts Identification
truckparts@hendrickson-intl.com
Technical Support
techservices@hendrickson-intl.com



1.630.910.2899



Additional Hendrickson
Product Information
www.hendrickson-intl.com

www.hendrickson-intl.com



Truck Commercial Vehicle Systems
800 South Frontage Road
Woodridge, IL 60517-4904 USA

1.866.755.5968 (Toll-free U.S. and Canada)
1.630.910.2800 (Outside U.S. and Canada)
Fax 1.630.910.2899