

H ASSEMBLY INSTRUCTIONS

HAULMAAX® Saddle Assembly

SUBJECT: Service Kits Number 57974-050, -051

LIT NO: 59310-043

DATE: May 2011

REVISION: B

INTRODUCTION

This publication is intended to assist maintenance personnel with the installation of service kit numbers 57974-051 (HAULMAAX® 400) and 57974-050 (HAULMAAX 460 equipped with tie-bar bolsters) for saddle assembly replacement on the HAULMAAX rear suspension. These service kits and service instructions are intended to simultaneously replace both saddle assemblies on a vehicle.

Refer to Hendrickson HAULMAAX Technical Publication 17730-244 for preventive maintenance, tightening torque interval guidelines, complete service and safety instructions, available online at www.hendrickson-intl.com.

CAUTION

A TECHNICIAN USING A SERVICE PROCEDURE OR TOOL WHICH HAS NOT BEEN RECOMMENDED BY HENDRICKSON MUST FIRST SATISFY HIMSELF THAT NEITHER HIS SAFETY NOR THE VEHICLE'S SAFETY WILL BE JEOPARDIZED BY THE METHOD OR TOOL SELECTED. INDIVIDUALS DEVIATING IN ANY MANNER FROM THE INSTRUCTIONS PROVIDED WILL ASSUME ALL RISKS OF CONSEQUENTIAL PERSONAL INJURY OR DAMAGE TO EQUIPMENT INVOLVED.

CAUTION

WEAR PROPER EYE PROTECTION TO HELP AVOID SERIOUS PERSONAL INJURY.

WARNING

DISCARD USED FASTENERS. ALWAYS USE NEW FASTENERS TO COMPLETE A REPAIR. FAILURE TO DO SO COULD RESULT IN FAILURE OF THE PART, OR MATING COMPONENTS, LOSS OF VEHICLE CONTROL, PERSONAL INJURY, OR PROPERTY DAMAGE.

To obtain maximum service life from the HAULMAAX suspension Hendrickson recommends inspecting the suspension, including fastener torque values, at pre-delivery, the first 1,000 miles of service, and at regular annual preventive maintenance intervals.

NOTE

Off highway and severe service operating conditions require more frequent inspections than on-highway service. Fastener torque values should be checked at least once a year and corrected to specified torque when necessary. For Hendrickson supplied fasteners, use the torque values supplied in this publication. For non-Hendrickson supplied fasteners, use the torque values supplied by the vehicle manufacturer.

NOTE

Hendrickson recommends the use of Grade 8 bolts and Grade C locknuts for all bolted joints. If flange head bolts and locknuts are not used then hardened structural washers must be used under the bolt heads and locknuts.

Saddle Assembly Service Kit Contents (Vehicle Set)

HAULMAAX 400 Kit No. 57974-051

| DESCRIPTION | QTY. |
|--|------|
| Saddle Assembly | 2 |
| ½"-13 UNC 2.25" Flange Bolt | 10 |
| ½"-13 UNC Flange Nut | 42 |
| Outboard Frame Bracket to Saddle Assembly Fastener Kit | 1 |
| ⅝"-11 UNC 1.50" Dacromet Flange Bolt | 8 |
| ⅝"-11 UNC Dacromet Flange Nut | 8 |

HAULMAAX 460 w/Tie-bar Bolsters Kit No. 57974-050

| DESCRIPTION | QTY. |
|--|------|
| Saddle Assembly | 2 |
| ½"-13 UNC 2.25" Flange Bolt | 10 |
| ½"-13 UNC 10.0" Flange Bolt | 4 |
| ½"-13 UNC Flange Nut | 46 |
| Outboard Frame Bracket to Saddle Assembly Fastener Kit | 1 |
| Bolster Spring Spacer | 4 |
| ⅝"-11 UNC 1.50" Dacromet Flange Bolt | 8 |
| ⅝"-11 UNC Dacromet Flange Nut | 8 |

SADDLE ASSEMBLY

NOTE

When changing both saddle assemblies, simultaneously perform the following replacement steps on both sides of the vehicle.

DISASSEMBLY

1. Chock the front wheels of the vehicle.
2. Raise the vehicle and remove the rear tires.
3. Support both rear axles with jack stands.
4. Remove the upper fasteners from the rebound clip and auxiliary spring bracket, see Figure 1.
5. Remove and discard the fasteners connecting the auxiliary spring assembly to the saddle and the auxiliary spring spacer, see Figure 1. Remove the auxiliary spring assembly.
6. Loosen, **DO NOT** remove, the 1/2" flange head locknuts connecting the bolster springs/tie-bar bolster springs to the saddle assembly.
7. Remove and discard the 1/2" fasteners connecting the bolster springs / tie-bar bolster springs to the equalizing beam.
8. Remove the tie-bar bolt and spacer (if equipped).
9. Remove and discard the 5/8" fasteners from the auxiliary spring contact plate and equalizing beam, see Figure 1.
10. Remove the auxiliary spring contact plate.
11. Remove and discard the upper shock absorber fasteners (if equipped), from the upper shock brackets. Push the shock absorbers down and clear of the upper shock brackets.

FIGURE 1

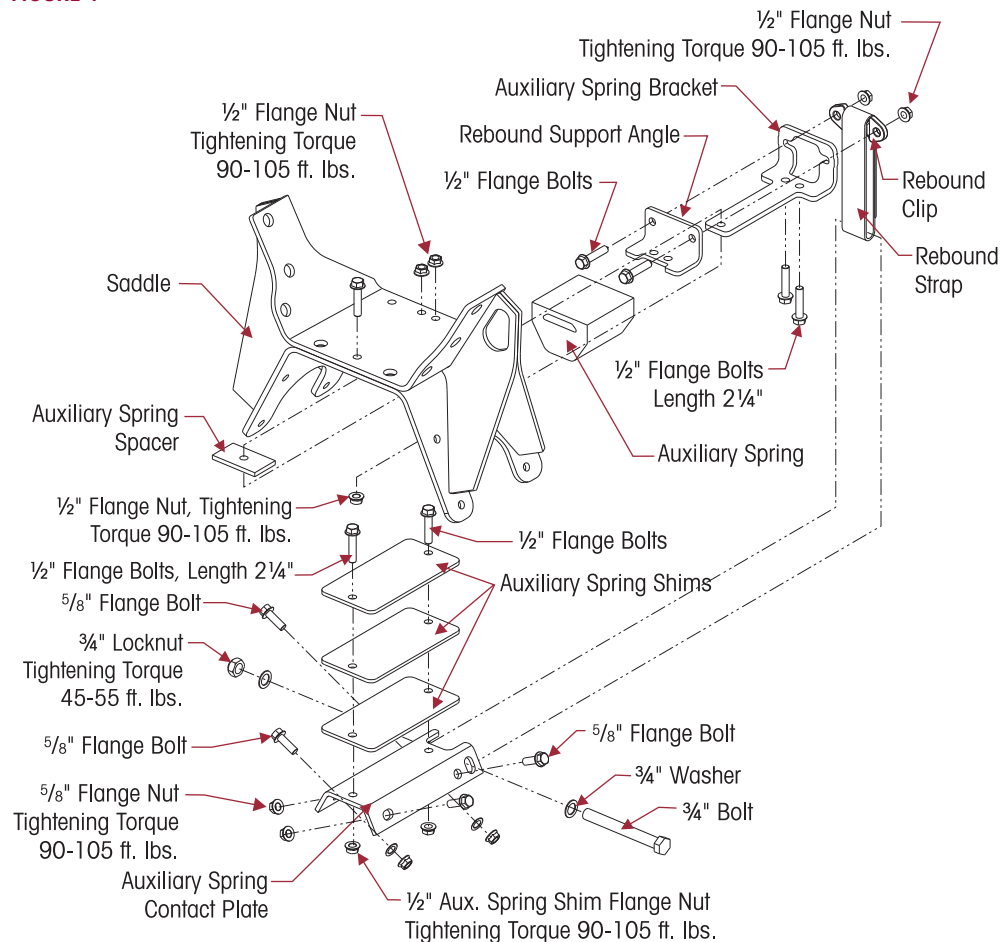

12. Raise the rear of the vehicle to clear the bolster springs/ tie-bar bolster springs from the equalizing beam. Support the vehicle at this height.
13. Remove and discard the ½" fasteners that connect the bolster springs / tie-bar bolster springs to the saddle, and remove the bolster springs, see Figure 2.

WARNING

THE WEIGHT OF THE SADDLE IS APPROXIMATELY 70 POUNDS. CARE SHOULD BE TAKEN AT REMOVAL AND INSTALLATION TO PREVENT PERSONAL INJURY OR DAMAGE TO COMPONENTS.

14. Remove and discard the M20 fasteners from the saddle and outboard frame bracket, see Figure 3.
15. Remove the saddle.

ASSEMBLY

1. Mount the new saddle to the outboard frame bracket by installing the M20 fasteners and tighten to 280-340 foot pounds torque, see Figure 3.
2. Mount the bolster springs/ tie-bar bolster springs to the saddle and loosely install the ½" flange head locknuts on the bolster spring studs. **DO NOT** tighten at this time.
3. If equipped with a tie-bar bolster spring, install the tie-bar bolt from the outboard side. Install the bolt through the outboard bolster mount, the tie-bar sleeve and the inboard bolster mount. Install the tie-bar locknut and tighten to 90-105 foot pounds torque.

FIGURE 2

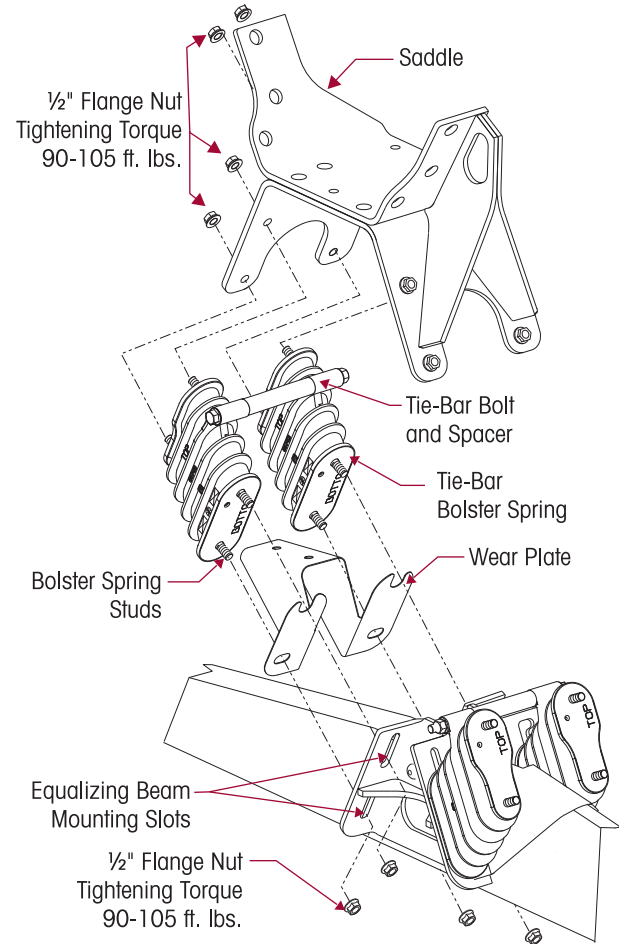
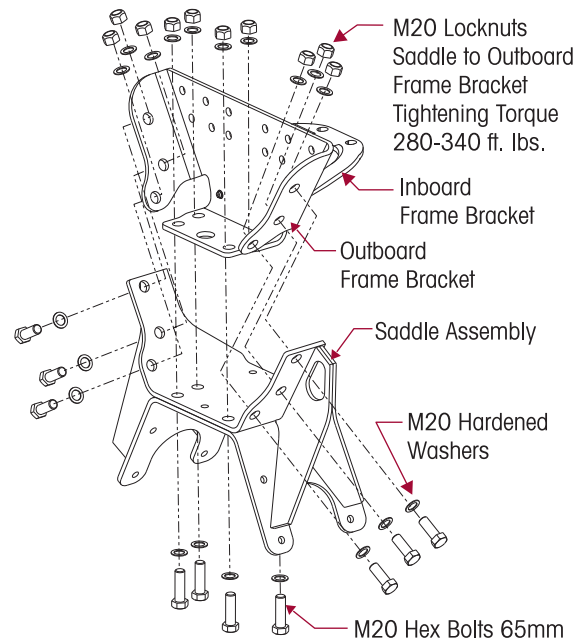

FIGURE 3



 **CAUTION**

IF THE WEAR PLATES LOCATED BETWEEN THE EQUALIZING BEAM AND THE BOLSTER SPRINGS/TIE-BAR BOLSTER SPRINGS ARE DAMAGED, THEY MUST BE REPLACED. FAILURE TO DO SO CAN CAUSE DAMAGE TO MATING COMPONENTS.





4. Remove the frame supports and lower the vehicle, guiding the lower bolster spring studs into the wear plates and equalizing beam mounting slots. Ensure bolster spring studs sit at the bottom of the mounting slots on the beam, see Figure 2.
5. Install the lower ½" flange head locknuts on the bolster spring studs and tighten both upper and lower bolster spring fasteners to  90-105 foot pounds torque.

FIGURE 4

6. Mount the auxiliary spring contact plate on the equalizing beam by installing the fasteners. Tighten to  90-105 foot pounds torque, see Figure 4.
7. Locate the shock absorbers (if equipped) into the upper shock bracket and install the fasteners, tighten to  150-170 foot pounds torque.
8. Mount auxiliary spring assembly with auxiliary spring and auxiliary spring spacer to saddle by installing the ½" flange head bolts through the auxiliary spring bracket, see Figure 1. Install the flange head locknuts and tighten the ½" flange bolts to  90-105 foot pounds torque.
9. Mount the rebound clip and rebound strap to auxiliary spring bracket by installing the ½" flange head bolts and flange head locknuts and tighten to  90-105 foot pounds torque.
10. Remove the jack stands and install tires.
11. Lower the vehicle.
12. Remove wheel chocks.

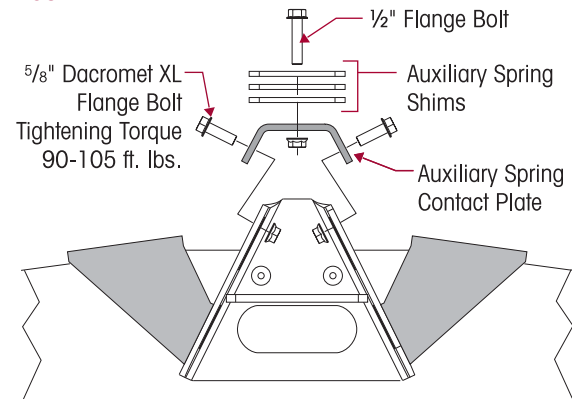
Refer any questions regarding this publication to Hendrickson Tech Services toll-free at 1-866-755-5968 or email: techservices@hendrickson-intl.com. Go to our website for more information on Hendrickson products, www.hendrickson-intl.com.

www.hendrickson-intl.com



Truck Suspension Systems
800 South Frontage Road
Woodridge, IL 60517-4904 USA

630.910.2800
Fax 630.910.2899