

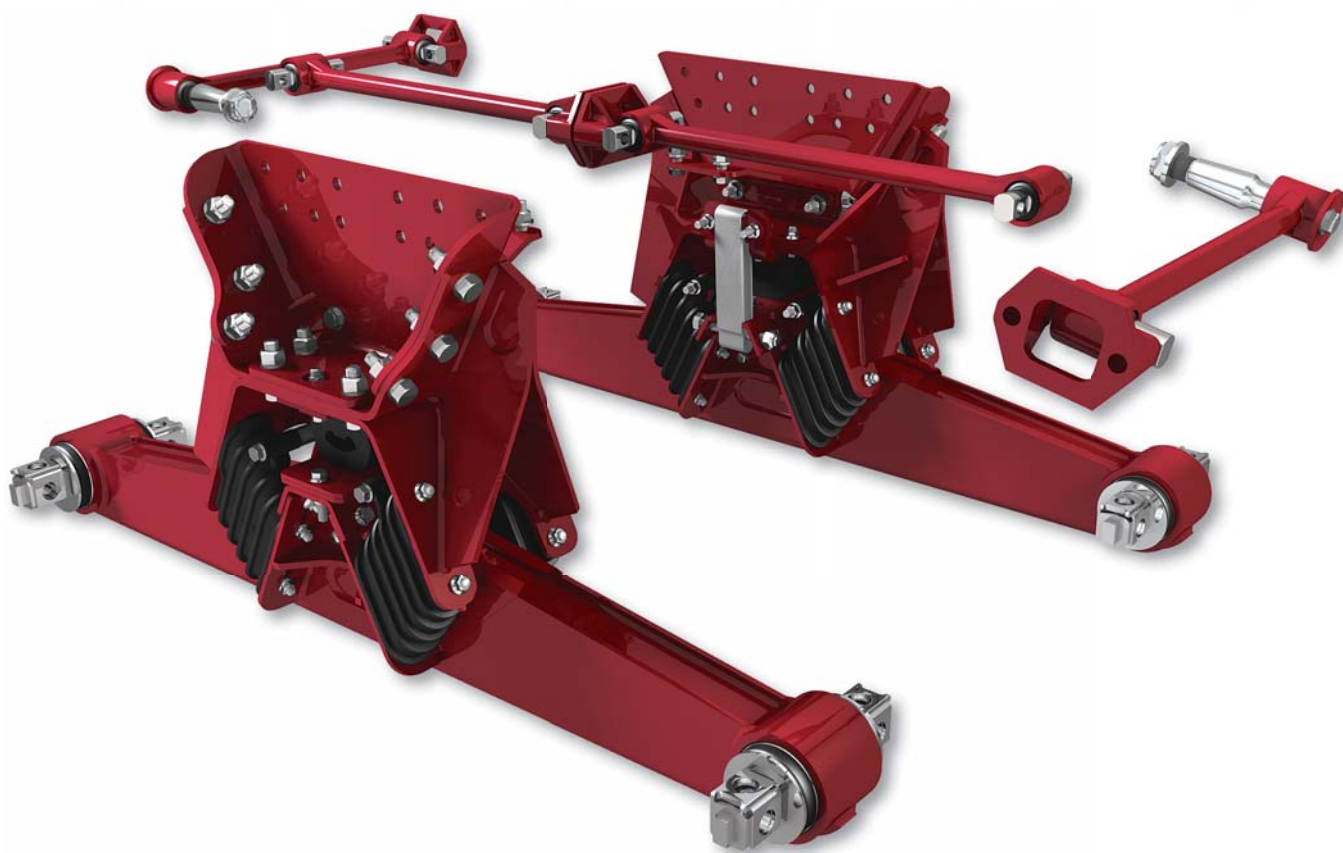

Heavy-duty Lightweight Rubber Suspension

- MAAximize payload
- MAAximize driver comfort
- MAAximize durability



To learn more about HAULMAAX,
call 855.743.3733 or visit
www.hendrickson-intl.com

 **HENDRICKSON**
The World Rides On Us®

MAAXimize Payload and Durability

Suspension weight is reduced for greater payloads and improved durability through innovative design, higher strength materials and advanced manufacturing methods. Proven with extensive vehicle durability and laboratory testing, HAULMAAX® delivers the reliability and quality you've come to expect from Hendrickson, the leader in suspension technology.

Hendrickson Rods

- Improve cornering by controlling lateral forces
- Transverse rods ensure maximum lateral axle control and straight line suspension stability
- Longitudinal rods engineered to optimize resistance to wind up during acceleration and braking

Saddle and Frame Bracket

- Lightweight, modular design simplifies installation

Progressive Load Spring

- Newly designed to always engage for smoother ride and additional stability
- Eliminates shim adjustments for lower maintenance**

Premium Rubber Bolster Springs

- The unique design works with the Progressive Load Spring to deliver unparalleled empty ride quality and loaded stability

Bar Pin End Connection

- Rugged axle connection extends bushing life and allows easy axle alignment and serviceability

Equalizing Beam

- Formed and robotically-welded beam provides a narrow profile for weight savings
- Distributes load equally between both axles for improved traction
- Lowers the center of gravity to increase stability
- Establishes a solid axle connection for improved handling
- Center bushing eliminated for reduced maintenance

Shock Absorbers

- Provide additional driver comfort
- Required for tractor and logging applications
- Available as production or aftermarket options

46,000 lbs. Weight Comparison*

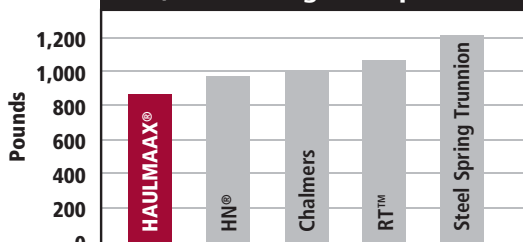

* Weight includes the suspension system and related components. Above data is based upon internal testing and/or published specifications. Actual product specifications and performance may vary depending upon suspension and vehicle configuration, operation, service and other factors.

** For most applications.

MAAXimize Driver Comfort and Confidence

The updated HAULMAAX® spring system easily adjusts to the load for an enhanced combination of empty-ride quality and loaded stability. Extra wide bolster spring centers and a unique progressive load spring provide exceptional stability for demanding applications such as refuse, concrete mixers and dump.

New Feature: Progressive Load Spring

- Engages in unloaded and loaded conditions
- Helps improve empty and loaded ride quality
- Eliminates adjustments for most applications

How it Works:



Unloaded

- Rubber bolster springs act in shear and compression to help provide optimum spring deflection for outstanding ride quality. Bolster springs absorb vertical road inputs and fore / aft shock.
- Progressive Load Spring is always engaged to maximize empty ride quality.



Loaded

- Rubber bolster springs compress and stiffen as payload increases, while maintaining excellent ride quality.
- Progressive Load Spring engages further for additional stability.

MAAXimize Uptime

Help reduce life cycle costs and increase the uptime of your vehicle:

- Improved ride reduces road shock and vibration to the vehicle for longer service life and fewer repairs to the cab, chassis and body equipment
- No lubrication requirements
- Fewer bushings to maintain — center bushing eliminated
- Rubber springs provide long service life and easy replacement
- Bar pin end bushing extends service life and provides alignment capability for longer tire life
- Hendrickson torque rod bushings provide longer service life than conventional bushings
- Hendrickson parts and service available at thousands of locations worldwide
- Comprehensive technical support, training and warranty

MAAXimize Traction

HAULMAAX provides the versatility for demanding job-site or off-road conditions. When loaded, HAULMAAX delivers up to 17 inches* of diagonal wheel articulation to keep load on all drive wheels. Unloaded articulation varies with vehicle configuration and empty body weight. In addition, unlike other walking-beam suspensions, the innovative HAULMAAX design eliminates fixed center bushing pivot points to reduce wheel hop.

* Suspension articulation may exceed vehicle's capability and may be limited by vehicle manufacturer; vehicle manufacturer installed axle stops may restrict suspension's articulation.

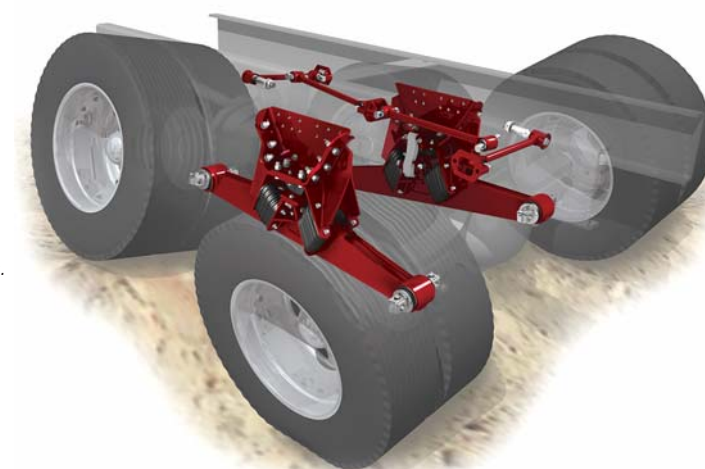

HAULMAAX[®] Specifications

	HMX 400	HMX 460
Installed Weight¹ (54 in. axle spacing)	855 lbs.	861 lbs.
Suspension Rating	40,000 lbs.	46,000 lbs.
GVW Approval²	73,000 lbs.	80,000 lbs.
GCW Approval	160,000 lbs.	190,000 lbs.
Site Travel Rating³	55,000 lbs.	60,000 lbs.
Diagonal Articulation⁴	17 in.	17 in.
Lift Axles	Approved	Approved
Ride Heights (loaded)⁵	9.5 in., 10.5 in., 11.5 in., 13.25 in., 15.5 in.	9.5 in., 10.5 in., 11.5 in., 13.25 in., 15.5 in.
Axle Spacing⁶	52 in., 54 in., 60 in., 72.5 in.	52 in., 54 in., 60 in., 72.5 in.
Shock Absorber Applications⁷	Tractors, Logging	Tractors, Logging

Hendrickson approves the use of HAULMAAX in the following vocational truck applications: dump, concrete mixer, refuse, logging, crane / boom, platform and fire / rescue. All such applications must comply with applicable Hendrickson specifications and must also be approved by the respective vehicle manufacturer with the vehicle in its original, as-built configuration. Contact Hendrickson and the respective vehicle manufacturer for approval of additional applications.

1. Installed weight includes complete suspension, torque rods, axle brackets and frame brackets; add 31 lbs. for shock absorbers.
2. Contact Hendrickson for applications that may exceed GVW approval ratings.
3. Site travel rating — operators using vehicles equipped with liftable pusher or tag axles must not exceed published ratings. Ratings are limited to no more than five percent of vehicle operation at speed not to exceed five mph. Liftable pusher or tag axles should only be raised (or unloaded) to improve vehicle maneuverability in off-road use or when vehicle is empty. Site travel ratings are consistent with published axle manufacturer's limitations. Axle and suspension site travel specifications must not be exceeded.
4. Suspension articulation may exceed vehicle's capability and may be limited by vehicle manufacturer; vehicle manufacturer installed axle stops may restrict suspension's articulation.
5. HAULMAAX ride height measurements are taken from the centerline of the axle to the bottom of the truck frame.
6. Contact Hendrickson for availability of beam lengths.
7. Shock absorbers are required in tractor and logging applications. Ride and traction may be improved in other applications with shock absorbers. Ride performance can be subjective and may be dependent on many factors beyond the suspension design such as cab suspension, road conditions, body/auxiliary equipment, frame specifications, etc. Contact Hendrickson or your truck manufacturer/dealer for further information.



Optional shock absorbers

For additional details regarding specifications; applications; capacities; and operating, service and maintenance instructions, refer to applicable Hendrickson technical literature (available at www.hendrickson-intl.com) or contact Hendrickson at 866.755.5968.

Actual product performance may vary depending upon vehicle configuration, operation, service and other factors.

U.S. and foreign patents granted and/or pending. Technical literature available at www.hendrickson-intl.com or contact Hendrickson at 866.755.5968.

Hendrickson Genuine Parts are the same quality components installed in Hendrickson original equipment suspensions — consisting of the same design, construction, performance and durability. There's only one way to maintain and protect your suspension's original performance. Ask for the name that is synonymous with the finest manufactured suspensions in the world.

Extended Warranty options available at www.hendrickson-intl.com

Call your truck dealer or Hendrickson at **630.910.2800** or **855.RIDERED (743.3733)** for additional information.



www.hendrickson-intl.com

TRUCK COMMERCIAL VEHICLE SYSTEMS

800 South Frontage Road
Woodridge, IL 60517-4904 USA
855.RIDERED (743.3733)
630.910.2800 • Fax 630.910.2899