



**R<sup>TM</sup> 1000**

**H HENDRICKSON**

*The World Rides On Us<sup>®</sup>*

# R™ 1000 – MAXIMIZE DURABILITY AND STABILITY

**R 1000 solid mount suspension** — designed for the rigorous demands of vocational, severe service and heavy haul applications where superior durability, maximum stability and off-road maneuverability is essential.

## Genuine Hendrickson Torque Rods

- Longitudinal torque rods engineered to optimize resistance to frame raise during acceleration and braking
- Improve cornering by controlling lateral forces

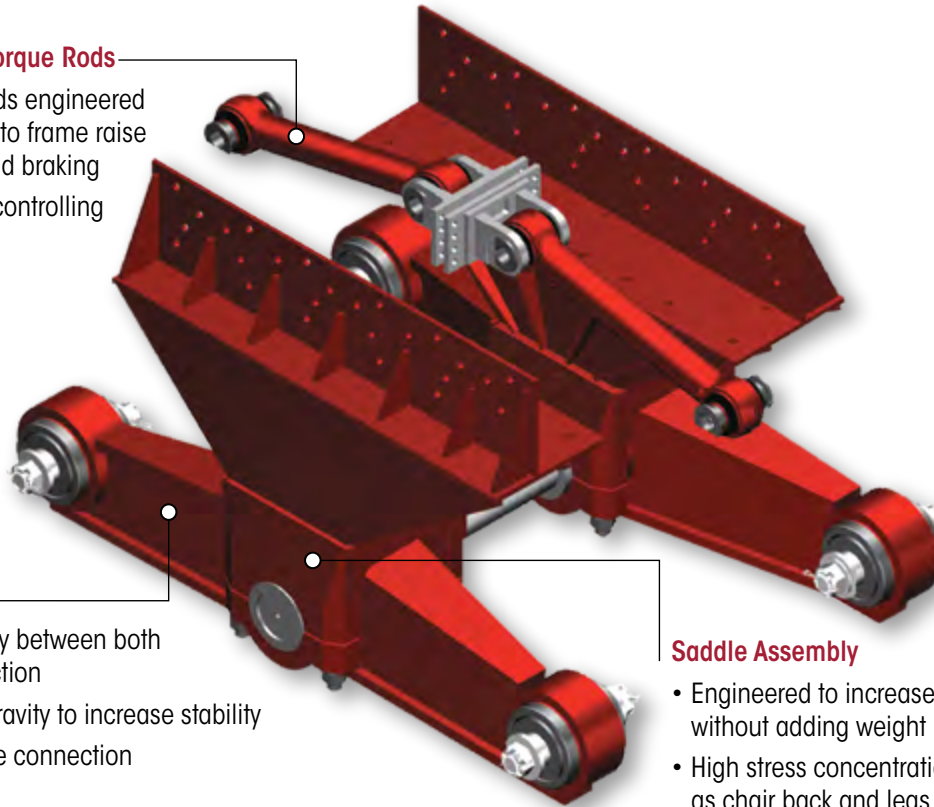

## Equalizing Beam

- Distributes load equally between both axles for improved traction
- Lowers the center of gravity to increase stability
- Establishes a solid axle connection for improved handling

## Saddle Assembly

- Engineered to increase durability without adding weight
- High stress concentration areas such as chair back and legs are fortified for strength and durability

## R 1000 Specifications

Beam Type	Installed Weight <sup>1</sup>	Suspension Rating	Site Travel Rating <sup>2</sup>	Articulation	Lift Axle	Axle Spacing
Fabricated	3,894 lb.	100,000 lb.	110,000 lb.	17.0"	Yes	64"

<sup>1</sup> **Installed Weight:** includes complete suspension, torque rods and frame brackets. Based on standard 64" axle spacing.

<sup>2</sup> **Site Travel Rating:** Ratings are limited to no more than 5% of vehicle operation at speed not to exceed 5 mph. Site travel ratings are consistent with published axle manufacturer's limitations. Axle and suspension site travel ratings cannot be exceeded.

Note: Photography and illustrations in this publication may depict optional equipment. All equipment and specifications shown in this publication are subject to change without notice. Consult your Mack dealer at the time of ordering for actual standard and optional equipment.



**Mack Trucks Inc.**

1-800-922-MACK (6225)

[www.macktrucks.com](http://www.macktrucks.com)

Visit [www.hendrickson-intl.com](http://www.hendrickson-intl.com) for additional information